Vehicle and Operator Services Agency

The MOT Inspection Manual

Private Passenger and Light Commercial Vehicle Testing

Preface

This Manual sets out the testing procedures and standards for those who carry out statutory testing of cars, private buses and light commercial vehicles.

Vehicle owners may also find the Manual useful because it details the inspection to which vehicles are subjected and the reasons why an MOT test certificate could be refused.

This Manual was based on the domestic regulations in force at the time of publication and complies with Annex II to Directive 2009/40/EC as amended by Commission Directive 2010/48/EU. Future changes in the law, or in vehicle or equipment design may result in variations to the test requirements.

General information regarding documentation and the responsibilities of those involved in testing are contained in the Vehicle and Operator Services Agency MOT Testing Guide.

Written by the Vehicle and Operator Services Agency

© Crown copyright. Published by Atos on behalf of the Vehicle & Operator Services Agency – to whom applications to reproduce material should be made in writing c/o Procurement Unit, Berkeley House, Croydon Street, Bristol, BS5 0DA.

First Edition crown copyright 1992

Fifth consolidated edition 2002

Second Edition crown copyright 2004

Third Edition crown copyright 2010

Fourth Edition crown copyright 2011

ISBN 978-0-9549352-5-2

Introduction	Abbreviations and Definitions	Section 3	Brakes
	Introduction	3.1	Parking Brake Control
	How to Use this Manual	3.2	Hand Operated Brake Control Valves
	Recommended Inspection Routine	3.3	Service Brake Control
Section 1	Lamps, Reflectors and Electrical Equipment	3.4	Anti-Lock Braking and Electronic Stability Control Systems
1.1	Front and Rear Position Lamps, End Outline Marker Lamps, Registration Plate Lamps	3.5	Mechanical Brake Components
1.2	Stop Lamps	3.6	Braking Systems and Additional Braking Devices
1.3	Rear Fog Lamps	3.7	Brake Performance
1.4	Direction Indicators and Hazard Warning Lamps	3.8	Method of Calculating Brake Performance
1.5	Rear Reflectors	3.9	Example of Manufacturers Plate
1.6	Audible Warning (Horn)	3.10	Brake Efficiency Table
1.7	Headlamps	Section 4	Tyres and Road Wheels
1.8	Headlamp Aim	4.1	Tyres
1.9	Electrical Wiring and Battery	4.2	Road Wheels
Section 2	Steering and Suspension	Section 5	Seat Belts & Supplementary Restraint Systems (SRS)
2.1	Steering Control	5.1	Seat Belt Requirements
2.2	Steering System	5.2	Seat Belt Condition
2.3	Power Steering	5.3	Seat Belt Installation Check (Class 4A & 5A only)
2.4	Suspension – General	5.4	Supplementary Restraint Systems (SRS)
2.5	Front Suspension, Wheel Bearings and Drive Shafts		
2.6	Rear Suspension and Wheel Bearings		
2.7	Shock Absorbers		
2.8	Suspension Type Diagrams		

Section 6 Body, Structure and General Items

- 6.1 Vehicle Structure, Body and General Items
- 6.2 Seats and Doors
- 6.3 Registration Plates and Vehicle Identification Number
- 6.4 Load Security, Spare Wheel and Carrier
- 6.5 Speed Limiter
- 6.6 Towbars
- 6.7 Speedometer
- 6.8 Driving Controls (Class 5 only)
- 6.9 Glazing (Class 5 only)

Section 7 Exhaust, Fuel and Emissions

- 7.1 Exhaust System
- 7.2 Fuel System
- 7.3 Exhaust Emissions-Spark Ignition
- 7.4 Exhaust Emissions-Compression Ignition

Section 8 Drivers View of the Road

- 8.1 View to Rear
- 8.2 Wipers and Washers
- 8.3 Windscreen
- 8.4 Bonnet

Section 9 Motor Tricycles and Quadricycles

- 9.1 Lighting
- 9.2 Motorcycle Derived Steering / Suspension
- 9.3 Brakes
- 9.4 Tyres and Road Wheels
- 9.5 Seat Belts
- 9.6 Body and Structure
- 9.7 Exhaust, Fuel and Emissions
- 9.8 Drivers View of the Road

Appendices

- A Reserved For Future Use
- B Reserved For Future Use
- C Structural Integrity and Corrosion
- D Tyre Size, Ply Rating and Load Index Tables

Section Contents

Item	Subject
------	---------

Abbreviations and Definitions

Introduction

1. Application (Classes 3, 4, 5 & 7)
2. Refusal to Test
3. Inspection Procedure
4. Narrow Track Vehicles
5. Retest Following Failure
6. Recording Defects
 - a) Reasons for Rejection
 - b) Dangerous Defects
 - c) Other Defects
7. Testing Personnel
8. Vehicle Specific Information (VSI)
9. The MOT Testing Guide
10. The VTS Device User Guide
11. Road Testing
12. Health and Safety

Item	Subject
------	---------

How to Use This Manual

1. The Manual
2. Page Layout
 - a) Information Columns
 - b) Method of Inspection Columns
 - c) Reasons for Rejection Columns
 - d) Notes
3. Vehicle 'first used' Dates – Application of Test Criteria
4. Assessment of Component Wear and Deterioration
5. Modified Vehicles
6. Inappropriate Repair or Modification
7. Use of Equipment
8. Use of an Assistant
9. Disabled Driver's Controls
10. Special Notices (SNs) and Manual Replacement Pages

Recommended Topside Inspection Routine

Recommended Underside Inspection Routine

Abbreviations and Definitions

Abandon	The term used when a test cannot be completed because the NT considers it unsafe to continue or because it becomes apparent during the test that certain items cannot be satisfactorily inspected. An appropriate fee may be charged for the test.
Abort	The term used when a test cannot be completed because of a problem with the VTS's/DC's testing equipment or the NT. No fee may be charged for the test.
AE	Authorised Examiner - the organisation that operates and manages one or more VTSs and is responsible for controlling the quality of testing carried out. Except in the case of a 'sole trader' the AE is not a person but a legal entity (e.g. a company or partnership).
ATL	Automated Test Lane - These are lanes authorised by VOSA for use in the automated mode.
Bodied vehicles	A bodied vehicle is defined as 'a vehicle with a structure consisting/comprising of a floor pan and panels which, with a roof fully encloses the vehicle occupants and without a roof encloses them other than where the roof would be'. As a guide, if the driver sits in the vehicle with surrounding structure it would be classed as bodied.
Bus	A motor vehicle which is constructed or adapted to carry more than eight seated passengers (see also Minibus).
Catch Up	The process by which testing test data recorded while testing under Emergency Testing is subsequently entered via the VTS Device.
Coach	A motor vehicle which is constructed or adapted to carry more than 16 seated passengers, with a DGW of more than 7,500kg and a maximum speed in excess of 60mph.
DGW	Design Gross Weight - i.e. the maximum gross weight that the vehicle was designed to operate at by the manufacturer. This is normally found on the manufacturer's plate fixed to the vehicle, or in the case of older or heavier vehicles by a 'Ministry Plate'. Such plates are not required on all vehicles.
ET	Emergency Testing, the process by which testing may continue when the computerised system is not available due to a wide scale failure affecting a significant number of VTSs.
Fallback	The process by which testing may continue when the computerised system is not available at a VTS, for example, following the breakdown of the VTS Device.
Fallback Review	The process by which test data recorded while testing under Fallback is subsequently confirmed on the MOT computer database.
Immediately	Taking place without delay.
Large Class 4	A Class 4 vehicle with a DGW greater than 2500kg.
MAM	Maximum Authorised Mass – The maximum gross weight permissible in GB.
Minibus	A motor vehicle constructed or adapted to carry more than eight but no more than sixteen seated passengers (see also Bus).
Ministry Plate	Displays the maximum authorised weights at which a vehicle may be operated. This information supersedes the maximum weights displayed on the Manufacturer's plate.
Mol	Method of Inspection.

Abbreviations and Definitions

NT	Nominated Tester - a person nominated by an AE to carry out tests, Inspectors appointed by Designated Councils to carry out tests, all of which are approved by VOSA. Also VOSA staff appointed under section 66A of the Road Traffic Act 1988.
OPTL	One Person Test Lane. These are lanes authorised by VOSA to conduct testing where the tester has the option of not using an assistant if so desired.
Password	Personal Identification, used in conjunction with a Smart Card to access the MOT database via the VTS device. Can be numbers or letters, or a combination of both.
QC	Quality Control.
RfR	Reason for Rejection.
Replacement manual pages	Replacement pages are normally sent out under a Special Notice. They must be inserted into the manual immediately. Superseded pages should be removed.
Siemens	Siemens IT Solutions and Services Ltd – Service provider for MOT Computerisation.
Smart Card	A card issued to an authorised user to access the MOT database via the VTS Device.
SN	Special Notice - an official notice issued from time to time by VOSA to inform AEs, NTs and other system users of changes to the testing scheme. SNs may also be used to highlight areas of concern and to advise of developments of the scheme.
ULW	Unladen Weight - The weight of a vehicle inclusive of the body and all parts which are ordinarily used with the vehicle when working on a road. Unladen weight does not include the weight of water or fuel used for the propulsion of the vehicle, or of loose tools and loose equipment.
VOSA	The Vehicle and Operator Services Agency.
VSI	Vehicle Specific Information, provided to NTs to aid the correct assessment of a vehicle under test.
VT20	An MOT Test Certificate which includes the English/Welsh dual language version (VT20W).
VT20 ET	An MOT Test Certificate for issue during a period of Emergency Testing.
VT30	A notice of refusal of a MOT Test Certificate including the Welsh counterpart (VT30W).
VT32	An Advisory Notice – issued to advise of items of concern identified during the test that do not justify the refusal of a test certificate.
VT40	MOT Inspection Check List used by a NT during a test for vehicles other than motor bicycles (see VT40M).
VT40M	Motor bicycle MOT Inspection Check List used by a NT during a test.
VTS	Vehicle Test Station.
VTS Device	The Computer device installed at each VTS on which each test must be registered, from which MOT documentation is produced and to perform certain administrative functions.
V5/V5C	Vehicle log book/registration certificate. Issued by the Driver and Vehicle Licensing Agency.

1. Application (Classes 3, 4, 5 & 7)

This Manual is a detailed guide to the inspection for statutory MOT testing of the following Classes:

- Class 3 3 wheeled vehicles not more than 450kg unladen weight (excluding motor bicycles with side cars).
- Class 4 Cars, including 3 wheeled vehicles more than 450kg unladen weight, Taxis, Minibuses and Ambulances up to 12 passenger seats, Goods Vehicles not exceeding 3000kg Design Gross Weight (DGW), Motor Caravans and Dual Purpose Vehicles.
- Class 5 Private passenger vehicles, Ambulances, Motor Caravans and Dual Purpose Vehicles with 13 or more passenger seats.
- Class 7 Goods Vehicles over 3000kg up to and including 3500kg (DGW). If a vehicle is presented with a manufacturer's plate and a 'Ministry plate' the weights to be used are those on the 'Ministry plate'.

More detailed definitions are given in the MOT Testing Guide.

Note: To determine the seating capacity of a passenger vehicle, the number of occupied wheelchairs that can be carried should be added to the number of seats.

Tricycles and Quadricycles are tested under Classes 3 or 4 and these vehicles can present particular problems at MOT test.

Section 9 of this Manual provides **additional** information for testing these vehicle types. However, sub-section 9.2 should be used in place of Sections 2.1 and 2.2 for vehicles with motorcycle derived steering and/or suspension components fitted.

Other than for the inspection of tyres, any two wheels of a vehicle shall be regarded as one wheel if the distance between the centres of the areas of contact between such wheels and the road surface is less than 460 mm.

Note: A tester should be aware that this may affect the test Class, e.g. a three wheeled vehicle with a wheel layout meeting these criteria **must be tested as a motor bicycle**.

paragraph 1 continued

Table to Determine the Vehicle Class and Test Requirements for Tricycles and Quadricycles

Vehicle type	Description	Tested in Class
Moped	Three wheeled vehicle with max speed of 45km/h, not over 50cc for a petrol engine or 4KW for any other engine or electric motor, not more than 450kg ULW	3
Motor Tricycle	Three wheeled vehicle with wheels symmetrically arranged, a max speed over 45km/h, or engine size over 50cc, not more than 450kg ULW	3
Motor Tricycle	Three wheeled vehicle with wheels symmetrically arranged with a max speed over 45km/h, or engine size over 50cc, more than 450kg ULW	4
Light Quadricycle (classed as a moped)	Four wheeled vehicle with a max ULW of 350kg, max speed of 45km/h and not over 50cc for a petrol engine or 4KW for any other engine or electric motor.	4
Quadricycle	Four wheeled vehicle with a max ULW of 400kg (550kg for a goods vehicle) with a max net power of 15KW	4

If any of the above vehicles are electrically powered, their unladen weight must not include the weight of the batteries.

If there is doubt about the power output or the weight of the vehicle, the presenter must provide documentary evidence.

Cont'd ↓

2. Refusal to Test

This Manual does not include the reasons for refusing to test a vehicle in the Reasons for Rejection columns. VTSs may only test those Classes and types of vehicle that they are authorised to test and which are of a size and weight that can be accommodated by the authorised equipment.

If any of the following reasons apply, the test should not be carried out, the vehicle presenter informed and any fee paid for the test must be returned. It is therefore advised that 'refusal' items are checked before starting the test.

If the vehicle presenter requires written confirmation of why the test cannot be carried out, the test should be registered using the VTS Device. A VT30 should be issued clearly showing the reason(s) why the test could not be carried out.

If reason to refuse 'i' applies, issue a hand written VT30 containing as many of the vehicle details as possible. A copy of the VT30 should be retained by the VTS.

The reasons for refusing to carry out the test are:

- a. The log book / registration certificate or other evidence of the date of first use is not produced if the information therein, is necessary for the test to be carried out.

Note: Normally this evidence is only necessary if the vehicle has a 'cherished' registration mark or if the registration mark's year letter does not make clear the standard that should be applied - for instance, regarding Hazard Warning Device requirements for vehicles first used on or after 1 April 1986.

- b. The vehicle or any part or equipment on the vehicle is so dirty that examination is unreasonably difficult.
- c. The vehicle is not fit to be driven when necessary to complete the test because of a lack of fuel, or oil, or for any other reason.
- d. The NT considers insecurity of a load or other items would prevent a proper test being carried out - unless the load is secured or removed.

paragraph 2 continued

- e. The VTS asks for the fee to be paid in advance and this is not done.
- f. The vehicle emits **substantial** quantities of **avoidable** smoke.
- g. A proper examination cannot be carried out because any door, tailgate, boot, engine cover, fuel cap or other device designed to be readily opened cannot be readily opened.
- h. The condition of the vehicle is such that, in the opinion of the NT, a proper examination would involve a danger of injury to any person or damage to the vehicle or other property.
- i. The vehicle has neither registration mark nor VIN/Chassis No./Frame No. by which it can be identified, or that all such identifications are illegible or use letters and numbers not normally used in the English language.

In addition to this an NT must decline to test any vehicle that is not of a Class they are authorised to test or it is of such a size, weight or configuration it cannot be properly or safely tested on the approved facilities.

Note: For narrow track vehicles see item 4.

If despite due care initially, it becomes apparent during a test that the test cannot be completed **for any of the above reasons**, you must fail the vehicle because the test could not be satisfactorily completed.

Any re-examination and fee must be in line with normal policy (see Fees and Appeals Poster) treating the component which could not be examined as a failure item.

Cont'd ↓

3. Inspection Procedure

Each vehicle must be registered for test by the NT at the commencement of the test. This will normally be done via the VTS Device. When testing in Fallback, (see MOT Testing Guide) this must be done by contacting the Atos Service Desk. The only exception to this is when testing using ET procedures.

The NT who registered the vehicle for test must personally carry out the test, without avoidable distraction or interruption. Using a suitable assistant where necessary.

The diagrams on pages 11 and 12 show typical inspection routines which will aid the tester in making a thorough inspection of a vehicle. These routines may need to be varied to suit different test bay layouts and equipment types.

For example, at some testing stations, where the roller brake tester is positioned in advance of the pit or lift, it might be more convenient to conduct the brake performance test before inspecting the rest of the vehicle.

This practice is permissible, but it must be noted that a tester should not proceed with the brake performance test if there is a defect with the vehicle which could cause;

- injury to any person;
- or damage to the vehicle or other property.

It is advisable to examine, as far as possible, all of the vehicle before carrying out a brake performance test.

Testers are reminded to take care when jacking up vehicles in order to avoid causing damage, and may wish to refer to manufacturers' information if available.

Particular care is also needed when jacking vehicles fitted with pneumatic, hydraulic or self levelling suspension.

paragraph 3 continued

Once the inspection is completed, the NT must record the test results using the VTS Device, or by contacting the Atos Service Desk when testing in Fallback. The only exception to this is when testing using ET procedures.

Brake efforts achieved during a test should be recorded and entered on the VTS Device after the completion of the test as follows:

- Roller and plate brake tests- record the brake effort of each wheel tested and whether 'lock-up' occurs. Note also the maximum out-of-balance across each axle. The VTS Device will calculate the required results for service and parking brake efficiency as well as the out of balance result if required.
- Decelerometer tests - record the efficiencies recorded by the meter.
- Gradient tests - record the result (Pass or Fail).

During Fallback the NT must, calculate the efficiencies, supply appropriate values requested by the Atos Service Desk, and retain the readings for later data entry or confirmation.

If testing under ET, the brake efficiency of each system must be calculated by the NT and the readings retained for later data entry.

See the MOT Testing Guide for a full explanation of the procedures to be adopted during Fallback and ET.

If testing under ET the results, which are recorded under normal test conditions, should be recorded on the VT40 and any printout retained.

There is no requirement to jack the rear wheels of any vehicle in:

- Class 4 (where the DGW exceeds 5000Kg)
- or,
- Class 5.

Cont'd ↓

4. Narrow Track vehicles

Certain vehicles have a track width that may be too narrow for the vehicle to be safely tested on the approved pit or hoist.

Where this is the case, the inspection can be carried out on an area of hard standing within the testing facility, **only** where a headlamp aim test can be conducted using the approved equipment and with the vehicle placed in the headlamp aim standing area.

The tester should use an appropriate Method of Inspection covering all testable items set out in the Inspection Manual. Checks requiring the use of turning plates will need to be carried out on hard standing as best as possible.

It will be necessary to jack the vehicle to facilitate those checks that require raising the wheels clear of the ground, using any suitable jacking method.

If a roller brake test cannot be carried out, due to the track width or transmission type, then a decelerometer test must be conducted.

It is important to remember that this procedure only applies to vehicles with a track width so narrow that it would make it unsafe to use the pit / hoist. If a tester has any concerns whatsoever with regard to Health and Safety, they should decline to test the vehicle.

5. Retest Following Failure

Information on retest fees and procedures can be found in the current MOT Testing Guide and on the Fees and Appeals poster (VT9A).

When carrying out a partial retest the NT must examine:

- all the failed item(s)
- any item(s) that may have been affected by the repairs
- and any testable item that had been advised on at the time of the initial test.

If during a retest it is clear that any defect is present which would mean the issue of a test certificate is not justified, a further VT30 must be issued.

6. Recording Defects

a) Reasons for Rejection

The Reasons for Rejection within this Manual are selected using the VTS Device, via a component-based menu system.

The User will first select the vehicle component that is required. Then, via on-screen selection, select the appropriate Reason for Rejection.

Some Reasons for Rejection are not accessible due to, for instance the testable age of the vehicle.

b) Dangerous Defects

If in the opinion of the NT the vehicle has a dangerous defect this must be recorded in box C of the VT30 or in box C of the VT32 as appropriate. Dangerous defects must be clearly explained to the vehicle presenter.

c) Other Defects

It is considered best practice to advise the presenter of:

- any items which are near to, but which have not yet reached the point of test failure.
- any peculiarities of the vehicle identified during the inspection.
- any defects on non-testable items which are found during the inspection procedure.

Cont'd ↓

7. Testing Personnel

Inspections must be carried out by a properly approved NT. An assistant must be used, where necessary, to carry out the inspection correctly. The use of an assistant is not mandatory at an ATL or OPTL approved VTS using the acceptable ATL or OPTL equipment.

In appropriate cases, the person submitting the vehicle ('the vehicle presenter') is permitted to act as an assistant, if they are willing, the NT is satisfied with their competence and that all Health and Safety requirements are met. For example, the vehicle presenter will normally be capable of operating light switches etc., but might not be able to properly push, pull or lever road wheels etc.

Only the NT carrying out the inspection is empowered to make a decision about the results of the inspection of a particular item.

8. Vehicle Specific Information (VSI)

The computerised MOT system will provide NTs with additional information about the vehicle under test in the form of VSI.

VSI may also include information regarding the test methods and/or standards to be adopted, where alternatives exist within this Manual.

Some VSI will normally be provided on the MOT checklist (VT40), NT's should access any further information, where this is provided via the VTS device.

When testing under Fallback, VSI will be available via the Atos Service Desk.

VSI may not be available when testing under ET.

9. The MOT Testing Guide

The Guide explains what is required of people and organisations authorised to conduct statutory tests on certain motor vehicles. It includes amongst other things, the administration of the MOT scheme.

10. The VTS Device User Guide

The VTS Device User Guide, which forms part of the MOT Testing Guide, explains how to use the VTS Device.

11. Road Testing

The statutory test does not specifically include a road test of the vehicle. However, one is permitted if the NT considers it necessary to check the results of an inspection.

The NT must be qualified to carry out the road test. The NT must also ensure it is safe to conduct the road test.

12. Health and Safety

AEs and their staff are reminded that they are obliged to adhere to all relevant Health and Safety Legislation while MOT testing.

Advice can be obtained from your local Health and Safety Enforcement Officer or Local Authority Environmental Health Officers as appropriate.

Note: Electric/Combustion Engine (Hybrid) Vehicles

Care should be taken with hybrid vehicles as:

- there may be high voltage present at any one of several points around the vehicle
- the engine may start without warning if the battery voltage drops
- high voltage may be present in storage capacitors as well as batteries.

How to Use This Manual

1. The Manual

This Manual is written on the assumption that the inspection will be carried out by a qualified NT, with an assistant working under their direction, unless using an approved ATL or OPTL where the use of an assistant is not mandatory.

It should be read in conjunction with all current Special Notices relevant to the class of vehicle under test.

Further guidance may be gained by consulting the Vehicle Specific Information held on the MOT database for the vehicle under test.

2. Page Layout

a) Information Columns

These contain important details an NT needs to know, and should be used in conjunction with the other columns.

b) Method of Inspection Columns

These detail the way in which the inspection of items on the vehicle must be carried out and any equipment to be used.

The MOT test must be carried out without any dismantling, so it is not always practicable to inspect testable items completely.

Bonnets, engine covers, luggage compartments, access flaps and passenger compartment doors must be opened where this is necessary to inspect testable items that cannot otherwise be seen.

If, because the vehicle is loaded or a bonnet, door etc. cannot be opened or has been significantly reduced in size, you cannot gain access to a testable item, which was originally accessible **only** through a bonnet, door, access panel, etc., you must either abandon or refuse to carry out the test (see Item 2 of the Introduction).

paragraph 2 continued

c) Reasons for Rejection Columns

These list the defects that result in a vehicle failing the MOT test.

d) Notes

When carrying out each inspection, the NT should pay particular attention to the 'Notes' since they give valuable guidance on the conduct of the test and the scope of the inspection.

3. Vehicle 'first used' Dates - Application of Test Criteria

NT's will normally be provided with the vehicle details as part of the Vehicle Specific Information supplied by the MOT database. This will usually include the vehicle's 'first used' date. Where this information is available, the NT should only use Reasons for Rejection applicable to the vehicle's age.

However, in cases where this information is not available or incorrect, the NT should determine the vehicle's 'first used' date as follows:

- a. Its date of manufacture, if the vehicle was originally used without being registered in GB (e.g., an imported vehicle or ex-HM Forces vehicle), or
- b. Vehicles having a Q plate registration when presented for MOT are to be treated as follows: **For emission purposes only**, all these types are to be considered as vehicles first used before **1 August 1975**. **For all other testing purposes** they are to be considered as being first used on **1 January 1971**, or
- c. In any other case, the earlier of either:
 - Its date of first registration, or
 - The date six months after it was manufactured.

This information should be entered onto the VTS Device to enable the NT to select the appropriate Reason for Rejection.

Cont'd ↓

paragraph 3 continued

Examples of 'first used' Dates

- (i) The requirements for rear seat belts apply to vehicles first used after 31 March 1987, but vehicles manufactured at least 6 months previously (i.e. before October 1986) do not require rear seat belts.
- (ii) The exhaust emission test for a vehicle first used before August 1975 is a visual check only. Vehicles first used on or after 1 August 1975 are also subject to only a visual check if they were manufactured before February 1975 (i.e. 6 months or more before August 1975).

4. Assessment of Component Wear and Deterioration

Because it is not practicable to lay down limits of wear and tolerances for all types of components on different models of vehicle, a NT is expected to use experience and judgement in assessing the condition of a component.

The main criteria to be used when making such an assessment are:

- a. whether the component has reached the stage where it is obviously likely to affect adversely the roadworthiness of the vehicle
- b. whether the condition of the component has clearly reached the stage when replacement, repair or adjustment is necessary.

5. Modified Vehicles

Where a vehicle has been extensively modified or converted, certain Reasons for Rejection, such as for components 'missing where fitted as standard' should not be applied, for example:

- a car converted for rally use (i.e. rear seats removed and fitted with a roll cage and full harness seat belts etc.) may have been converted so as not to require a brake servo, power steering or airbags
- a car converted to a stretch limousine may no longer be fitted with curtain airbags or functional Electronic Stability Control.

6. Inappropriate Repair or Modification

Repairs and modifications to vehicles must be assessed on their merits, taking account of the nature and function of the component.

The main criterion to be used when assessing repairs is whether the repair is obviously likely to adversely affect the roadworthiness of the vehicle. In respect of modifications, the main criterion should be whether the modification has seriously weakened the component

7. Use of Equipment

The statutory test must be conducted using **only** equipment designated as acceptable for the test.

In the event of any item of designated test equipment failing, the VOSA local office must be notified. This will usually be via the VTS Device.

Testing must stop on any Class or type of vehicle as soon as any mandatory item of equipment malfunctions, in a way that could prevent a test being properly conducted on that Class or type of vehicle.

Where the failure is to a roller brake tester, testing may continue using a calibrated decelerometer for 2 working days, **only** for vehicles previously booked in before the breakdown occurred.

At approved ATL or OPTL VTSs where the failure is due to a wheel play detector then testing may continue using the conventional method with an assistant for those specific parts of the test.

The Vehicle and Operator Services Agency publishes a list of equipment which it has accepted for statutory testing within the relevant vehicle Classes. This does not apply to general workshop equipment such as levers, inspection lamps, tyre pressure gauges etc.

Cont'd ↓

8. Use of an Assistant

Some parts of the inspection require the use of an assistant to conduct an adequate examination of a component or system, for example some steering checks.

An assistant is not required when conducting inspections using an approved ATL or OPTL however, an assistant may be used if the NT considers it necessary.

9. Disabled Driver's Controls

A defective disabled driver's control or fitment that is a testable item justifies failure in the normal way.

The defect description must include an explanation of the control type or fitment and its clear function so that it is clear it applies to disabled driver's equipment.

If the disabled driver's controls or fitments are **additional** to and do not adversely affect the normal vehicle equipment, they are **not** testable items. Any defective additional control or fitment found during the test should be reported to the vehicle presenter.

10. Special Notices (SNs) and Inspection Manual Updates

Special Notices will be produced electronically via the VTS Device.

When instructed a printed copy of the SN must be filed and retained in a readily retrievable manner.

The SN may draw attention to changes of the electronic version of the Manual which will be updated automatically.

Appropriate VTS personnel will be notified of any changes or updates to the Manual.

Recommended Topside Inspection Routine

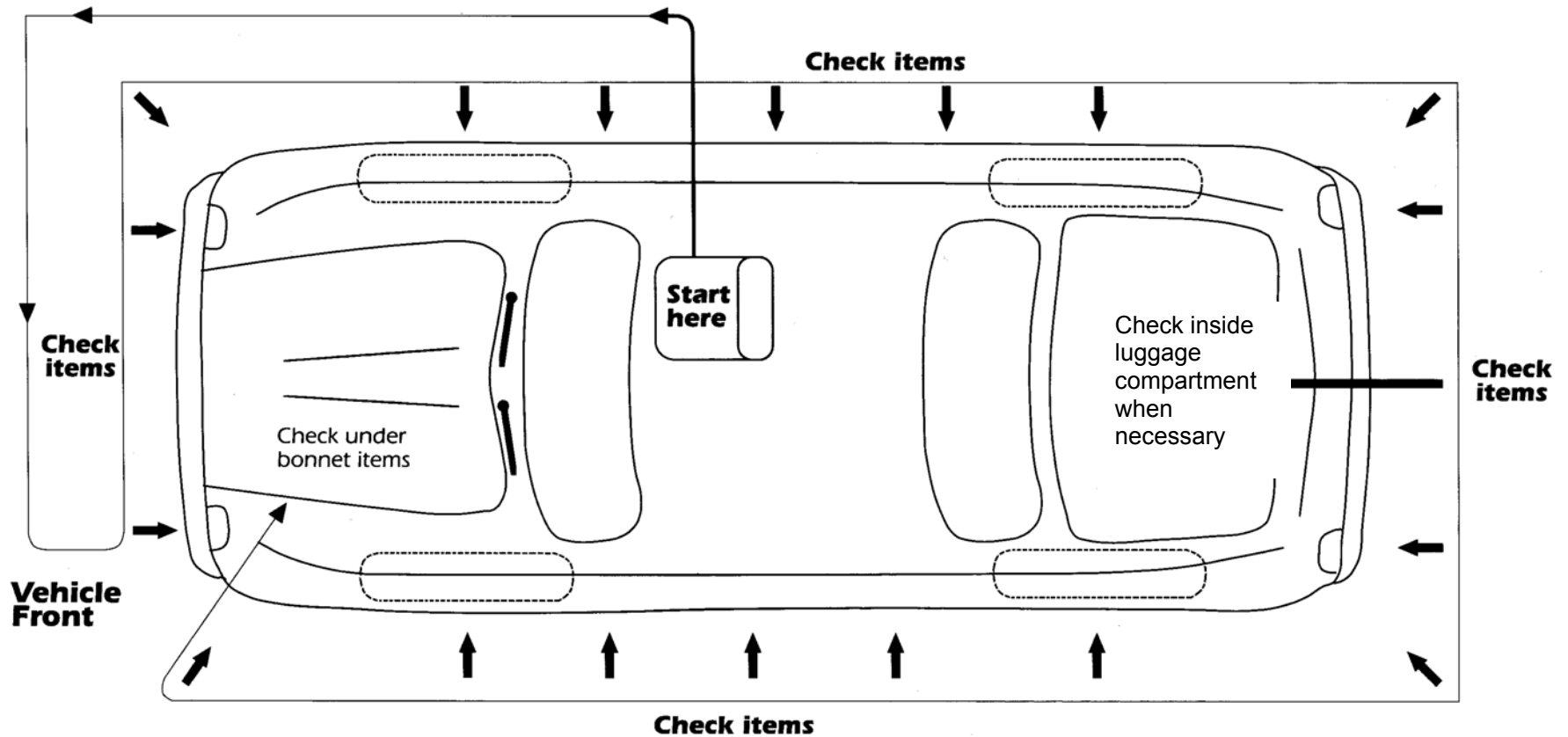

Recommended Underside Inspection Routine

Operations

1. With the wheels in the straight ahead position and supporting the vehicle weight, inspect the vehicle underside following the routine shown.
2. Jack up the front wheels to check relevant items.
3. There is no requirement to jack up the rear wheels of Class 5 vehicles or, Class 4 vehicles having a DGW exceeding 5000kg DGW.

Warning

When raising the vehicle on an elevated lift it is recommended that, prior to lifting the vehicle, the wheels are suitably chocked.

This is particularly important on vehicles over 3000kg DGW as lift automatic chocking devices are unlikely to provide sufficient resistance to vehicle movement.

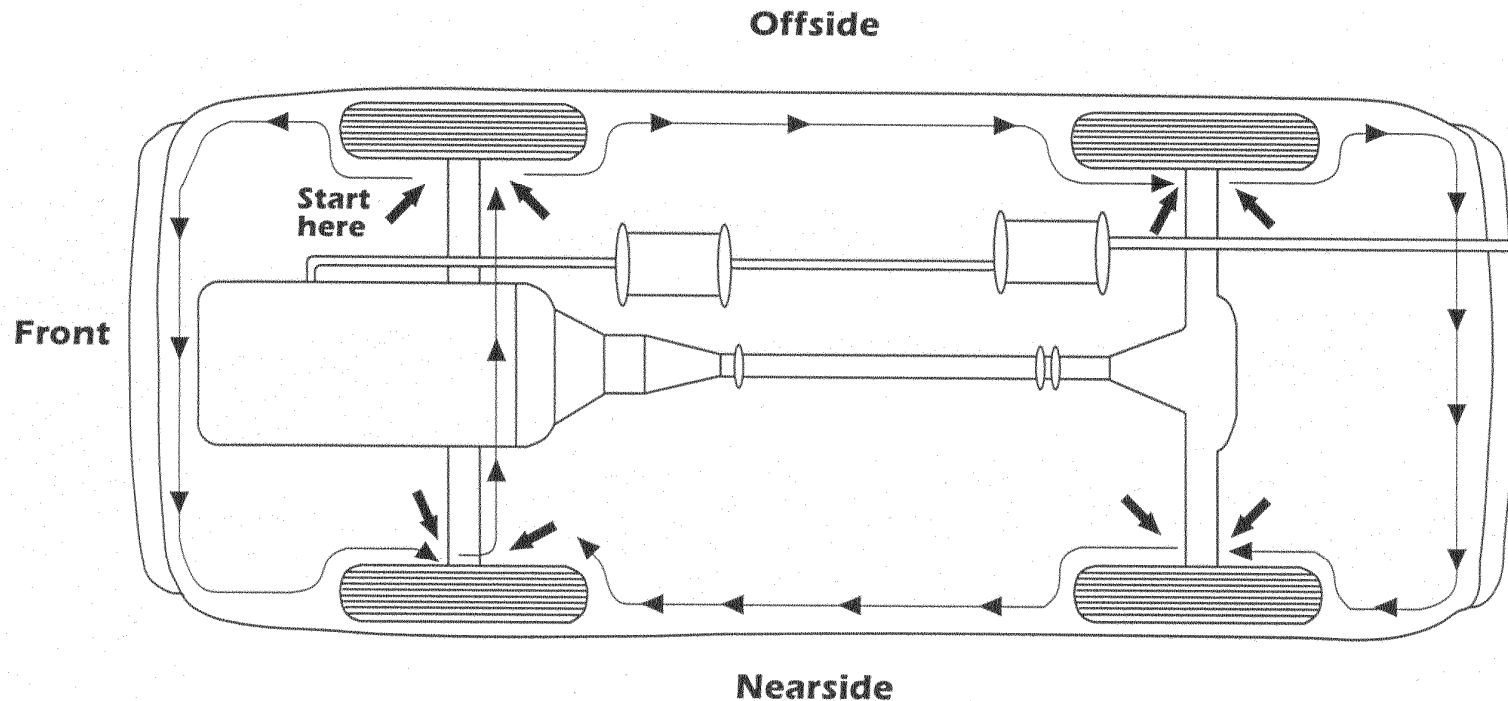

Lamps, Reflectors and Electrical Equipment

Section Contents

Sub-Section	Subject	Sub-Section	Subject
-------------	---------	-------------	---------

1.1	Front and Rear Position Lamps and Registration Plate Lamps	1.8	Headlamp Aim
-----	---	-----	---------------------

- A. Front and Rear Position Lamps
- B. End Outline marker Lamps (Class 5 only)
- C. Registration Plate Lamps

1.2	Stop Lamps	1.9	Electrical Wiring and Battery
-----	-------------------	-----	--------------------------------------

1.3	Rear Fog Lamps
-----	-----------------------

1.4	Direction Indicators and Hazard Warning Lamps
-----	--

- A. Flashing Type
- B. Hazard Warning Device
- C. Semaphore Type

1.5	Rear Reflectors
-----	------------------------

1.6	Audible Warning (Horn)
-----	-------------------------------

1.7	Headlamps
-----	------------------

- A. All Headlamps
- B. European 'E' Beam Headlamps
- C. British American Type (Main Beam)
- D. British American Type (Dipped Beam)

1.1 Front and Rear Position lamps and Registration Plate Lamps

Information	Method of Inspection	Reason for Rejection
<p>This inspection applies to all vehicles, except those which either have no front or rear position lamps or have such lamps permanently disconnected, painted over or masked that are:</p> <ul style="list-style-type: none"> only used during daylight hours, and not used at times of seriously reduced visibility. <p>If this situation occurs, the vehicle presenter should be issued with a VT32 (advisory notice) recording the above.</p> <p>Obligatory front and rear position lamps are lamps required by Regulations to be fitted to a vehicle to indicate its presence and width when viewed from the front or rear.</p> <p>Two front position lamps must be fitted, one on each side and show a steady white light to the front (or yellow if incorporated in a yellow headlamp).</p> <p>Two rear position lamps must also be fitted, one on each side, showing a steady red light to the rear.</p> <p>Note: A bus first used before 1 April 1955 requires only one rear position lamp on the centre-line or offside of the vehicle.</p> <p>Dim-dip headlamp systems require the front position lamps to be checked for operation with the ignition switched off. This may involve the operation of a separate switch.</p> <p>Additional or optional lamps are not included in the inspection.</p> <p>Tricycle and quadricycle requirements are detailed at Section 9.1.</p>	<p>A. Front and Rear Position Lamps</p> <ol style="list-style-type: none"> Check the presence and security of the switch. Check that the front and rear position lamps illuminate with a single operation of the switch. Note: Does not apply to military vehicles. Check that the lamps: <ol style="list-style-type: none"> are correctly positioned and secure Note: The precise position of obligatory lamps is not part of the inspection, but check visually that the lamps are at about the same height and the same distance from each side of the vehicle. are working are not obscured are in good condition Note: An effective proprietary repair (e.g. lens repair tape etc.) must be assessed on its merits, considering security, colour, light output and durability. show light of the correct colour Note: Some front position lamps have a blue tinge to the light. This is acceptable provided the light is predominantly white. are not adversely affected by the operation of any other lamp. 	<p>Reason for Rejection</p> <ol style="list-style-type: none"> A switch missing, insecure or not able to be operated from the normal driving position. The front and rear position lamps do not illuminate with a single operation of the switch. An obligatory lamp: <ol style="list-style-type: none"> missing, insecure, obviously incorrectly positioned or does not face to the front or rear as appropriate inoperative or less than 50% of the light sources illuminating obscured so that less than 50% of the lamp illuminating surface is visible from the front or rear as appropriate not visible from a reasonable distance due to excessive damage, deterioration, or having products on the lens or light source shows a light other than red to the rear and white to the front (or yellow if a front position lamp is incorporated in a yellow headlamp) adversely affected by the operation of any other lamp, e.g. dual-function lamps on foreign vehicles.

1.1 Front and Rear Position lamps and Registration Plate Lamps

Information	Method of Inspection	Reason for Rejection
<p>This inspection only applies to Class 5 vehicles fitted with front and rear position lamps.</p> <p>End outline marker lamps are required on vehicles:</p> <ul style="list-style-type: none"> • exceeding 2.1 metres (2100mm) in width, and • first used on or after 1 April 1991, and • are in addition to front and rear position lamps. <p>There must be two white lamps visible from the front positioned at windscreen upper edge level or higher and two red lamps visible from the rear, positioned as high as is practicable.</p> <p>Note: The front and rear end outline marker lamps may be combined in one lamp.</p>	<p>B. End outline marker lamps (Class 5 only)</p> <ol style="list-style-type: none"> 1. Turn on the position lamps and check that two front and two rear end outline marker lamps: <ol style="list-style-type: none"> a. illuminate simultaneously with the position lamps b. are securely fitted to the vehicle, one of each on each side <p>Note: The precise position of end outline marker lamps is not part of the inspection, but check visually that the lamps are not obviously incorrectly positioned.</p> <ol style="list-style-type: none"> c. are working d. are not obscured e. are in good condition <p>Note: An effective proprietary repair (e.g. lens repair tape etc.) must be assessed on its merits, considering security, colour, light output and durability.</p> <ol style="list-style-type: none"> f. show light of the correct colour g. are not adversely affected by the operation of any other lamp. 	<ol style="list-style-type: none"> 1. An obligatory end outline marker lamp: <ol style="list-style-type: none"> a. does not illuminate simultaneously with the position lamps b. missing, insecure, obviously incorrectly positioned or does not face to the front or rear as appropriate c. inoperative or less than 50% of the light sources illuminating d. obscured so that less than 50% of the lamp illuminating surface is visible from the front or rear as appropriate e. not visible from a reasonable distance due to excessive damage, deterioration, or having products on the lens or light source f. shows a light other than red to the rear and white to the front g. adversely affected by the operation of any other lamp.

1.1 Front and Rear Position lamps and Registration Plate Lamps

Information	Method of Inspection	Reason for Rejection
<p>This inspection applies to all vehicles fitted with front and rear position lamps.</p> <p>Registration plate lamps are required to illuminate the rear registration plate. Some vehicles may have these lamps fitted behind the number plate.</p> <p>Where more than one rear registration plate lamp is fitted, any one inoperative lamp is a Reason for Rejection.</p> <p>Tricycle and quadricycle requirements are detailed at Section 9.1.</p>	<p>C. Registration Plate Lamps</p> <ol style="list-style-type: none">1. Turn on the position lamps and check that registration plate lamp(s):<ol style="list-style-type: none">a. illuminate simultaneously with the position lampsb. are fittedc. are secured. are workinge. are correctly positionedf. does not show white light to the rear.	<ol style="list-style-type: none">1. A rear registration plate lamp:<ol style="list-style-type: none">a. does not illuminate simultaneously with the position lampsb. not fittedc. insecured. with any lamp not workinge. not illuminating the rear registration platef. shows white light directly to the rear.

1.2 Stop Lamps

Information	Method of Inspection	Reason for Rejection
<p>This inspection applies to all stop lamps fitted.</p> <p>Vehicles first used before 1 January 1936 are not required to be fitted with a stop lamp.</p> <p>Stop lamps are not required to be fitted to vehicles used only during the hours of daylight, which are fitted with neither front nor rear position lamps, etc. (See 1.1.A).</p> <p>Vehicles first used before 1 January 1971 must be fitted with one stop lamp either on or to the offside of the vehicle centre line. If such a vehicle has two lamps fitted, it should be treated as a vehicle first used on or after 1 January 1971.</p> <p>Vehicles first used on or after 1 January 1971 must be fitted with two obligatory stop lamps.</p> <p>Additional stop lamps fitted and connected must be tested. Where extra lamps are fitted and there is doubt as to whether they are connected, the benefit of this doubt should be given to the presenter.</p> <p>On vehicles first used before 1 September 1965 it is acceptable for a stop lamp to be incorporated with a direction indicator lamp.</p> <p>Tricycle and quadricycle requirements are detailed at Section 9.1.</p>	<p>1. Apply the service brake and check that the correct number of stop lamps:</p> <ul style="list-style-type: none">a. are correctly positioned and secure <p>Note: The precise position of obligatory lamps is not part of the inspection, but check visually that the lamps are at about the same height and the same distance from each side of the vehicle.</p> <ul style="list-style-type: none">b. are workingc. are not obscuredd. are in good condition <p>Note: An effective proprietary repair (e.g. lens repair tape etc.) must be assessed on its merits, considering security, colour, light output and durability.</p> <ul style="list-style-type: none">e. emit a steady red lightf. are not adversely affected by the operation of any other lamp.	<p>1. A stop lamp:</p> <ul style="list-style-type: none">a. missing, insecure, obviously incorrectly positioned or does not face to the rearb. inoperative or less than 50% of the light sources illuminatingc. obscured so that less than 50% of the lamp illuminating surface is visible from the reard. not visible from a reasonable distance due to excessive damage, deterioration, or having products on the lens or light sourcee. shows other than a steady red light to the rear when any service brake is applied, or remains on when the service brake is releasedf. adversely affected by the operation of any other lamp, e.g. dual-function lamps on foreign vehicles.

1.3 Rear Fog Lamps

Information	Method of Inspection	Reason for Rejection
<p>This inspection applies to the one rear fog lamp which is required to be fitted to the centre or offside of vehicles first used on or after 1 April 1980.</p> <p>Note: A rear fog lamp is permitted to operate independently of headlamp, position lamp or ignition systems.</p> <p>A rear fog lamp is not required to be fitted to vehicles used only during the hours of daylight, which are fitted with neither front nor rear position lamps, etc. (See 1.1.A).</p> <p>Tricycles and quadricycles are not required to be fitted with rear fog lamps.</p>	<ol style="list-style-type: none">1. With dipped head lamps and the ignition switched on, check:<ol style="list-style-type: none">a. the presence, security and operation of the switchb. the presence and operation of the 'tell-tale'.<p>Note: Some 'tell-tales' may be in the form of a coloured tag on a switch.</p>2. With the rear fog lamp(s) switched on check that a rear fog lamp:<ol style="list-style-type: none">a. is securely fitted to the centre or offside of the vehicleb. is workingc. is not obscuredd. is in good condition<p>Note: An effective proprietary repair (e.g. lens repair tape etc.) must be assessed on its merits, considering security, colour, light output and durability.</p><ol style="list-style-type: none">e. shows light of the correct colourf. is not adversely affected by the operation of any other lamp.	<ol style="list-style-type: none">1. A mandatory rear fog lamp switch:<ol style="list-style-type: none">a. missing, insecure, faulty, or not able to be operated from the normal driving positionb. 'tell-tale' missing or inoperative.2. A mandatory rear fog lamp:<ol style="list-style-type: none">a. missing, insecure, obviously incorrectly positioned or does not face to the rearb. inoperative or less than 50% of the light sources illuminatingc. obscured so that less than 50% of the lamp illuminating surface is visible from the reard. not visible from a reasonable distance due to excessive damage, deterioration, or having products on the lens or light sourcee. shows other than a steady red light to the rearf. adversely affected by the operation of any other lamp.

1.4 Direction Indicators and Hazard Warning Lamps

Information	Method of Inspection	Reason for Rejection
<p>This inspection applies to all direction indicators and hazard warning devices fitted.</p> <p>Direction indicators and hazard warning lamps are not required to be fitted to vehicles used only during the hours of daylight, which are fitted with neither front nor rear position lamps, etc. (See 1.1.A) Nor are they required on vehicles first used before 1 January 1936. However, if they are fitted, they must be tested.</p> <p>Vehicles first used before 1 September 1965 may have direction indicators incorporated with stop lamps, or combined with front or rear position lamps, in which case front indicators may be white and rear indicators red.</p> <p>Vehicles first used on or after 1 April 1986 must be fitted with one side repeater indicator on each side. Instead of a separate lamp, the side repeater might be part of the front direction indicator if it includes a wraparound lens.</p> <p>Lamps incorporating a side repeater are marked either with an 'E' mark in a circle or an 'e' mark in a rectangle above which is a number 5.</p> <p>However, some vehicles are fitted with a wraparound lens with no European approval markings. These can be tested by standing approximately 1000mm to the side of the vehicle's rear bumper with the indicator on. If amber light can be seen coming through the front lens (not a reflection) this is acceptable.</p> <p style="text-align: right;">Cont'd ↓</p>	<p>A. Flashing Type</p> <ol style="list-style-type: none"> 1. Check the presence, security and operation of the selector switch. 2. Operate the left and right direction indicators in turn and check: <ol style="list-style-type: none"> a. the driver's 'tell tale' warning device for presence and operation b. that the minimum number of direction indicators are securely fitted <p>Note: The precise position of direction indicators is not part of the inspection, but check visually that the lamps are at about the same height and the same distance from each side of the vehicle.</p> <ol style="list-style-type: none"> c. they are working d. they are not obscured e. they are in good condition <p>Note: An effective proprietary repair (e.g. lens repair tape etc.) must be assessed on its merits, considering security, colour, light output and durability.</p> <ol style="list-style-type: none"> f. that every direction indicator emits amber light (except vehicles first used before 1 September 1965) <p style="text-align: right;">Cont'd ↓</p>	<p>Reason for Rejection</p> <ol style="list-style-type: none"> 1. A selector switch missing, insecure, faulty, or not able to be operated from the normal driving position. 2. A direction indicator: <ol style="list-style-type: none"> a. 'tell tale' missing or inoperative b. missing, insecure, obviously incorrectly positioned or does not face to the front, rear or side as appropriate c. inoperative or less than 50% of the light sources illuminating d. obscured so that less than 50% of the lamp illuminating surface is visible from the front or rear as appropriate e. not visible from a reasonable distance due to excessive damage, deterioration, or having products on the lens or light source f. shows light of an incorrect colour <p style="text-align: right;">Cont'd ↓</p>

1.4 Direction Indicators and Hazard Warning Lamps

Information	Method of Inspection	Reason for Rejection
<p>Direction indicator ‘tell tales’ may be audible or visual. A ‘tell-tale’ is not required if one or more direction indicators on each side can be seen by the driver from the driver’s seat.</p> <p>Hazard warning devices are not required on vehicles first used before 1 April 1986, but if one is fitted it must be tested.</p> <p>The hazard warning lamp ‘tell tale’ may be a separate light or the same as the indicator ‘tell-tale’. However, it must be a flashing light.</p> <p>Tricycle and quadricycle requirements are detailed at Section 9.1.</p> <p>A semaphore arm must illuminate when in operation. It may flash, but is not required to do so.</p>	<p>g. the flashing rate</p> <p>Note: It may be necessary to run the engine when checking the flashing rate.</p> <p>h. they are not adversely affected by the operation of any other lamp.</p> <p>B. Hazard Warning Device</p> <p>1. Check that the hazard warning device:</p> <ul style="list-style-type: none"> a. is fitted (where required) b. is working c. operates using only one switch d. switch for presence, security and operation e. ‘tell-tale’ is working correctly f. operates all the direction indicators simultaneously with the ignition switched both on and off. <p>C. Semaphore Type</p> <p>1. Operate the direction indicators and check:</p> <ul style="list-style-type: none"> a. the operation of each indicator b. that every direction indicator emits an amber light c. selector switch presence, security, condition and operation. <p>2. Check the correct operation of the ‘tell-tale’.</p>	<p>g. does not flash at 60 to 120 times per minute</p> <p>h. adversely affected by the operation of another lamp e.g. dual function lamps on foreign vehicles.</p> <p>1. A hazard warning device:</p> <ul style="list-style-type: none"> a. not fitted b. inoperative c. operated by more than one switch d. switch missing, insecure or faulty e. ‘tell-tale’ not working correctly f. does not cause all the direction indicators to flash simultaneously, with the ignition both on and off. <p>1. A semaphore arm:</p> <ul style="list-style-type: none"> a. does not extend or retract smoothly b. does not show an amber light to the front and rear c. a selector switch missing, insecure or faulty. <p>2. The ‘tell-tale’ is missing or not working correctly.</p>

1.5 Reflectors

Information	Method of Inspection	Reason for Rejection
<p>This inspection applies to the two obligatory rear reflectors that are required by Regulation to be fitted.</p> <p>Rear reflectors are not required to be fitted to vehicles used only during the hours of daylight, which are fitted with neither front nor rear position lamps, etc. (See 1.1.A).</p> <p>Approval marks are not included in the inspection.</p> <p>Reflective tape is not acceptable as a substitute for a rear reflector.</p> <p>Tricycle and quadricycle requirements are detailed at Section 9.1.</p>	<ol style="list-style-type: none">1. Check that the required numbers of reflectors are:<ol style="list-style-type: none">a. fitted<p>Note: The precise position of obligatory rear reflectors is not part of the inspection, but check visually that they are at about the same height and the same distance from each side of the vehicle.</p>b. are not obscuredc. in good working orderd. red in colour.	<ol style="list-style-type: none">1. A reflector:<ol style="list-style-type: none">a. missing, insecure, obviously incorrectly positioned or does not face to the rearb. obscured so that less than 50% of the reflecting surface is visible from the rearc. excessively damaged or deteriorated so that less than 50% of the reflecting surface is functioningd. not red in colour.

1.6 Audible Warning (Horn)

Information	Method of Inspection	Reason for Rejection
<p>Pre 1906 vehicles can have a gong, bell or siren audible warning, provided they were designed before 1 January 1905 and constructed before 31 December 1905.</p>	<ol style="list-style-type: none">1. Check the presence, security and operation of the horn control. 2. Operate the horn and note the volume and character of the sound emitted.	<ol style="list-style-type: none">1. The horn control missing, insecure or not readily accessible to the driver. Note: Inform the driver if the horn is insecure. 2. The horn:<ol style="list-style-type: none">a. inoperativeb. is not loud enough to be heard by another road userc. is a gong, bell or sirend. has more than one tone Note: When operated, a two or more tone horn automatically produces a sound which alternates at regular intervals between fixed notes.e. fitted to a vehicle first used on or after 1 August 1973, emits a sound which is:<ul style="list-style-type: none">▪ not a continuous or uniform note▪ harsh or grating.

1.7 Headlamps

Information	Method of Inspection	Reason for Rejection
<p>This inspection applies to all obligatory headlamps fitted. Inspection of headlamp levelling and cleaning devices and the main beam tell-tale do not apply to Class 3 vehicles.</p> <p>Headlamps are not required to be fitted to vehicles used only during the hours of daylight, which are fitted with neither front nor rear position lamps, etc. (See 1.1.A).</p> <p>Vehicles equipped with High Intensity Discharge (HID) or LED dipped beam headlamps may be fitted with headlamp washers and a suspension or headlamp self levelling system.</p> <p>Where such systems are fitted, they must work; however, it is accepted that it may not be possible to readily determine the functioning of self levelling systems. In such cases, the benefit of the doubt must be given.</p> <p>Headlamp washers may work in conjunction with the windscreen washers (when the dipped beam headlamps are switched on) or by a separate switch.</p> <p>HID lamps may be identified by:</p> <ul style="list-style-type: none"> • taking a few seconds to reach full intensity • having a bluish tinge to the light • having an igniter module/inverter behind the headlamp • having 'DCR' marked on the headlamp lens. <p>HID headlamps use high voltage and extra care should be taken when inspecting these items.</p> <p style="text-align: right;">Cont'd ↓</p>	<p>Method of Inspection</p> <ol style="list-style-type: none"> 1. Check the presence, security and operation of the headlamp switch. 2. Where HID or LED dipped beam headlamps are fitted, switch on the headlamps and check the operation of any headlamp levelling and cleaning devices fitted. 3. Check that the vehicle is securely fitted with obligatory headlamps, as follows: <ul style="list-style-type: none"> • a matched pair of main beam headlamps, and • a matched pair of dipped-beam headlamps <p>Note: Main and dipped-beam functions may be provided by a single pair of headlamps.</p> 4. With the headlamps on, switch between dipped and main beams checking that: <ol style="list-style-type: none"> a. each headlamp illuminates immediately it is switched to either dipped or main beam b. either: <ul style="list-style-type: none"> • all main beams are switched off by one switch (dip switch) leaving a matched pair of dipped-beams switched on, or • the main beam headlamp reflectors are deflected by a driver's control, to make them dipped beams c. on vehicles first used on or after 1 April 1986, the 'tell-tale' illuminates when main beam is selected. <p style="text-align: right;">Cont'd ↓</p>	<p>Reason for Rejection</p> <ol style="list-style-type: none"> 1. A switch missing, insecure or faulty. 2. A headlamp levelling or cleaning device inoperative or otherwise obviously defective. 3. A missing, insecure or obviously incorrectly positioned obligatory headlamp. <p>Note: Class 3 vehicles may require only one headlamp (see Section 9.1).</p> <p>Note: The precise position of headlamps is not part of the inspection, but check visually that the lamps are at about the same height and the same distance from each side of the vehicle.</p> 4. <ol style="list-style-type: none"> a. A headlamp does not operate immediately when selected on dipped or on main beam b. operation of the dip switch does not: <ul style="list-style-type: none"> • extinguish all main beam headlamps, and leave on at least one pair of dipped-beam headlamps, or • deflect the main beams to make them dipped beams. c. the 'tell-tale' does not illuminate when main beam is selected. <p style="text-align: right;">Cont'd ↓</p>

1.7 Headlamps

Information	Method of Inspection	Reason for Rejection
<p>Vehicles first used before 1 January 1931 are not required to be fitted with headlamps. However, if optional headlamps are fitted:</p> <ul style="list-style-type: none">• where one is fitted it must dip• where two are fitted, either both must dip or one must dip and the other switches off. <p>Care must be taken to ensure that relatively large front lamps on old vehicles are headlamps and not merely position lamps.</p> <p>A “matched pair” is a pair of lamps which:</p> <ul style="list-style-type: none">• both emit light of substantially the same colour and intensity, and• are both the same size and of such a shape that they are symmetrical to one another. <p>In a four-headlamp system the outer pair of headlamps need not emit the same colour light as the inner pair.</p> <p>Buses first used before 1 October 1969 are only required to be fitted with one headlamp. Where two are fitted, neither the main or dipped beams are required to form matched pair.</p> <p>Headlamp aim is covered by Section 1.8 of this Manual.</p> <p>Tricycle and quadricycle requirements are detailed at Section 9.1.</p>	<p>5. Check that each obligatory headlamp:</p> <ol style="list-style-type: none">a. is in good working order <p>Note: Any adverse effects due to headlamp lens damage or deterioration can also be assessed on checking beam aim (see 1.8). A repaired lens must be assessed on its merits.</p> <ol style="list-style-type: none">b. shows light of the correct colourc. is not affected by the operation of any other lamp. <p>6. Check that a headlamp that is intended to be one of a matched pair, emits light of the same colour and is the same size or shape as its counterpart.</p>	<p>5. An obligatory headlamp:</p> <ol style="list-style-type: none">a. inoperative, excessively damaged or deteriorated or has a product on the lens or light source so that the light output is well below that required to illuminate the road aheadb. an obligatory headlamp shows light that is not substantially white or yellowc. adversely affected by the operation of any other lamp. <p>6. An obligatory main or dipped beam headlamp intended to be a matched pair:</p> <ul style="list-style-type: none">• do not emit light of the same colour• are not the same size or shape.

1.8 Headlamp Aim

Information	Method of Inspection	Reason for Rejection
<p>This inspection applies to all obligatory headlamps and any optional (additional) dipped beam headlamps.</p> <p>The type of headlamp will determine whether the aim must be checked on main or dipped beam. See diagrams 1, 2 and 3, which include details appropriate to each headlamp type.</p> <p>A flat top or other alternative headlamp dipped beam pattern (not being one of the examples) is acceptable providing all of the beam upper edge, including any “peak” is contained within the appropriate tolerance band.</p> <p>These methods of inspection involve the use of beam checking equipment with a collecting lens.</p> <p>Masks or converter kits may be fitted to right hand dip headlamps to temporarily alter the lamp for use in the UK by removing the beam ‘kick-up’ to the right.</p> <p>A headlamp altered in this way is not a reason for rejection, if:</p> <ul style="list-style-type: none">a. the headlamp aim is not rejected for the reasons listed under diagram 1 (except that the top of the beam image will be a straight line)b. the light output is not unduly reduced - not usually a problem with commercially produced kitsc. the mask or converter is securely attached. <p style="text-align: right;">Cont'd ↓</p>	<p>A. All Headlamps</p> <p>Position the vehicle on the designated headlamp aim standing area.</p> <p>Follow the headlamp tester manufacturer’s user manual instructions, and align the headlamp aim equipment with the longitudinal axis of the vehicle.</p> <p>Align the centre of the collecting lens with the centre of the headlamp under test.</p> <p>Switch on the headlamps to the beam on which the headlamp is to be checked.</p> <p>Note: When checking headlamp aim on vehicles with hydro-pneumatic suspension systems, it is necessary to have the engine idling.</p> <p>Determine the appropriate headlamp beam image and its aim (See diagrams 1, 2 and 3).</p> <p>Older vehicles (approx. pre 1950) headlamps beam image may not conform to either Diagrams 1, 2 or 3. In such cases check:</p> <ul style="list-style-type: none">• dip beam headlamps are aimed so they do not dazzle, ie the beam image brightest part is aimed at least 0.5% below the horizontal <p>or for headlamps which cannot be checked on dipped beam,</p> <ul style="list-style-type: none">• main beam headlamps are aimed so that the beam image centre is on or slightly below the horizontal.	<ul style="list-style-type: none">1. A headlamp which does not conform to diagrams 1, 2 or 3 that has a beam image which is aimed so that it dazzles other road users.2. Projected beam image obviously incorrect, e.g. where the headlamp bulb is incorrectly fitted or the reflector is seriously corroded.

1.8 Headlamp Aim

Information

Where driver's beam aim controls are fitted the beam aim should be tested without altering the control setting except where this would result in failure for beam aim being too low. In such cases the beam aim should be re-checked with the control set at its 'highest' position.

When testing headlamps with complex lens systems i.e. those that have more than one lamp behind a single lens, it is essential that the headlamp aim test equipment is aligned exactly on the centre of the dipped beam pocket.

If when carrying out a normal test a clearly defined headlamp pattern cannot be seen, it will be necessary to move the vehicle closer to the test equipment.

It is essential that the car headlamp and test equipment are as close together as possible, otherwise the whole of the beam pattern may not be visible.

Repairs must not be carried out during an MOT test; however, minor adjustments to the headlamp aim are acceptable.

When adjusting European 'E' beam headlamps they should be set in accordance with the type approval marking which is either close to the vehicle manufacturer's plate or the headlamp.

For vehicles without a marking, the downward aim should be set to:

- 1.3%, if the headlamp centre **is not more than** 850 mm from the ground
- 2.0%, if the headlamp centre **is more than** 850 mm from the ground.

1.8 European 'E' Beam Headlamp (Checked on Dipped Beam)

Information	Method of Inspection	Reason for Rejection
<p>European type (Checked on dipped beam)</p> <p>Characteristics:</p> <p>(a) an asymmetric dipped beam pattern with:</p> <ul style="list-style-type: none"> a distinctive horizontal cut-off on the right, and a 15 degree wedge of light above the horizontal (the 'Kick up') towards the left <p>(b) a lens with one or more asymmetric stepped patterns moulded in the glass</p> <p>(c) a lens may carry a European approval mark:</p> <ul style="list-style-type: none"> a circle containing an 'E' and a number, or a rectangle containing an 'e', and a number. <p>The European approval mark should incorporate a single or double-headed arrow.</p> <p>A dip beam is denoted by either:</p> <ul style="list-style-type: none"> a capital letter 'C' above a capital 'E' a capital letter 'C' above an 'e'. 	<p>B. European 'E' Beam Headlamp</p> <ol style="list-style-type: none"> Check that any beam image 'kick up' is to the nearside. Check that for headlamps with centres not more than 850mm from the ground the image horizontal cut-off is between the 0.5% and 2% lines; i.e. the red tolerance band. Check that for headlamps with centres more than 850mm from the ground, the image horizontal cut-off is between 1.25% and 2.75% lines; i.e. the blue tolerance band. Check the beam image 'break point' is between the 2% and 0% vertical lines. 	<ol style="list-style-type: none"> The beam image 'kick-up' is to the offside. For headlamps with centres not more than 850mm from the ground the beam image horizontal cut-off is not between the horizontal 0.5% and 2% lines; i.e. the red tolerance band. For headlamps with centres more than 850mm from the ground, the beam image horizontal cut-off is not between the horizontal 1.25% and 2.75% lines; i.e. the blue tolerance band. The beam image 'break point' is to the right of the 0% vertical line or to the left of the vertical 2% line.

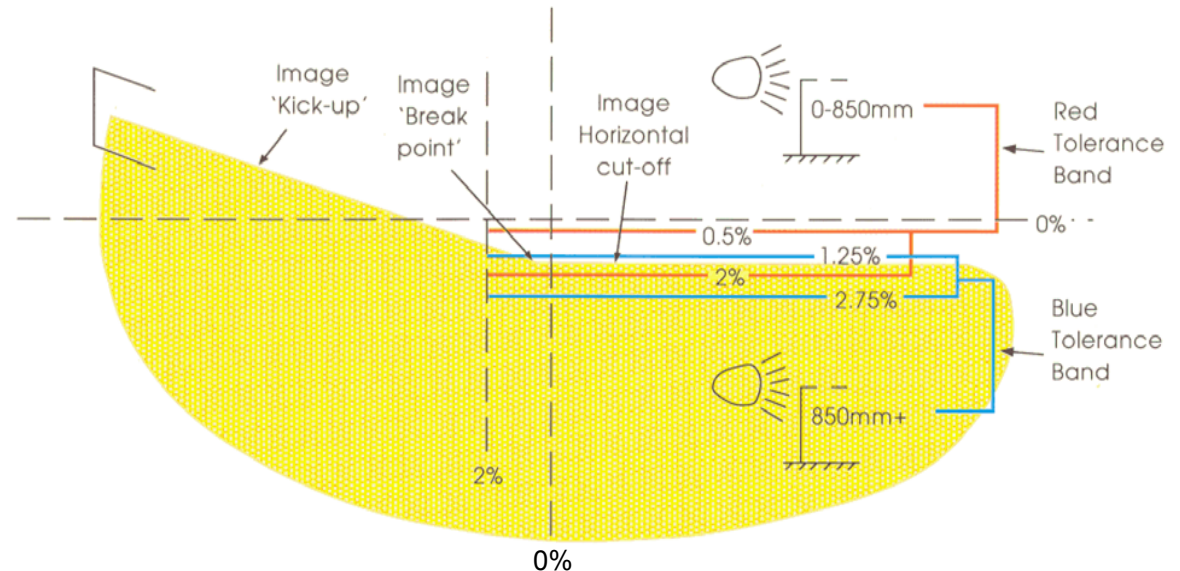

Diagram 1

Dipped beam image

Check the position of the 'break point' and horizontal cut-off

1.8 British American Headlamp (Checked on Main Beam)

Information	Method of Inspection	Reason for Rejection
<p>British American type (checked on main beam)</p> <p>Characteristics:</p> <p>(a) headlamps tested on main beam have a symmetrical main beam pattern with a central area of maximum intensity ('hot spot')</p> <p>(b) this type of lamp generally has a circular lens which may be marked with a figure '1' followed by an arrow indicating the direction of dip.</p>	<p>C. British American Type (Main Beam)</p> <ol style="list-style-type: none"> 1. Check the height of the centre of the 'hot spot'. 2. Check that for headlamps with centres not more than 850mm from the ground the 'hot spot' centre is not below the horizontal 2% line. 3. Check that for headlamps whose centre is more than 850 mm from the ground, the 'hot spot' centre is not below the horizontal 2.75% line. 4. Check that when dipped the brightest part of the image moves downwards. 5. Check the centre of the 'hot spot' is between the vertical 0% line and the vertical 2% line. 	<ol style="list-style-type: none"> 1. The 'hot spot' centre is above the horizontal 0% line. 2. For headlamps whose centre is not more than 850 mm from the ground the 'hot spot' centre is below the horizontal 2% line. 3. For headlamps whose centre is more than 850 mm from the ground, the 'hot spot' centre is below the horizontal 2.75% line. 4. When dipped the brightest part of the image does not move downwards. 5. The 'hot spot' centre is to the right of the vertical 0% line, or to the left of the vertical 2% line.

Diagram 2
Main beam image

Check the position of the centre of the area of maximum intensity ('hot spot')

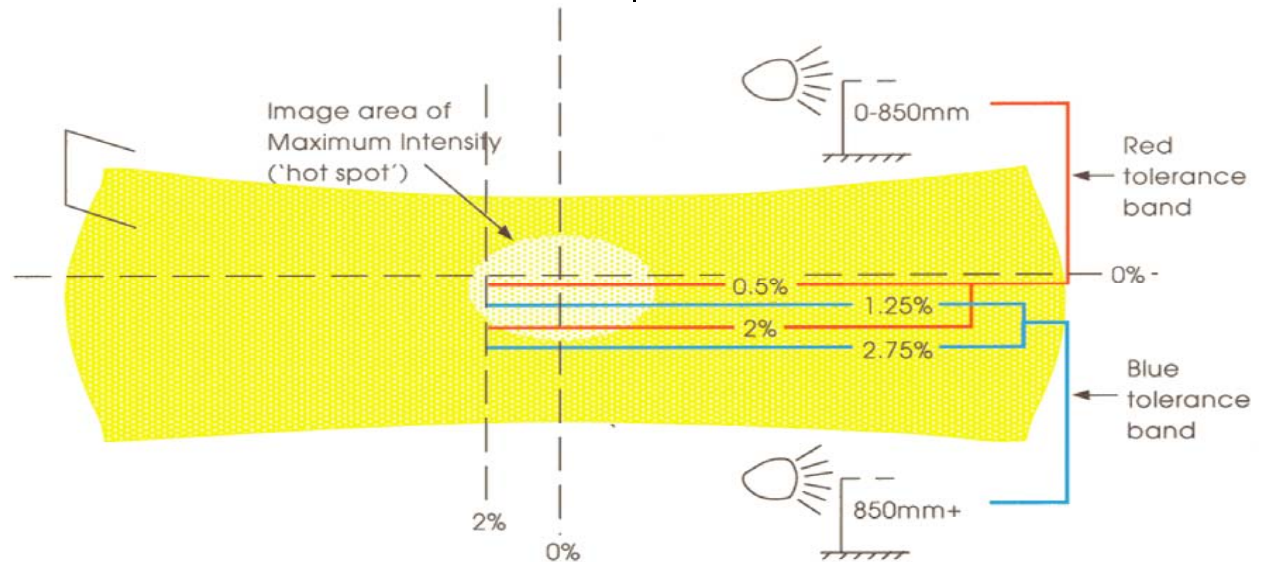

1.8 British American Type (Checked on Dipped Beam)

Information	Method of Inspection	Reason for Rejection
<p>British American type (Checked on dipped beam)</p> <p>Characteristics:</p> <ul style="list-style-type: none"> a. an asymmetric dipped beam pattern which when correctly aimed has a flat topped area of high intensity extending above and parallel with the horizontal zero line on the nearside b. a circular lens marked with the figure 2 which may also have an arrow showing the direction of dip. 	<p>D. British American Type (Dipped Beam)</p> <ol style="list-style-type: none"> 1. Check that the upper edge of the 'hot spot' is not above the horizontal 0% line. 2. Check that the upper edge of the 'hot spot' is not below the horizontal 2.75% line. 3. Check that the right hand edge of the 'hot spot' is between the vertical 0% line and the vertical 2% line. 	<ol style="list-style-type: none"> 1. The upper edge of the 'hot spot' is above the horizontal 0% line. 2. The upper edge of the 'hot spot' is below the horizontal 2.75% line. 3. The right hand edge of the 'hot spot' is to the right of the vertical 0% line or to the left of the vertical 2% line.

Diagram 3
Dipped beam image
Check the position of the upper and right hand edges of the 'hot spot'

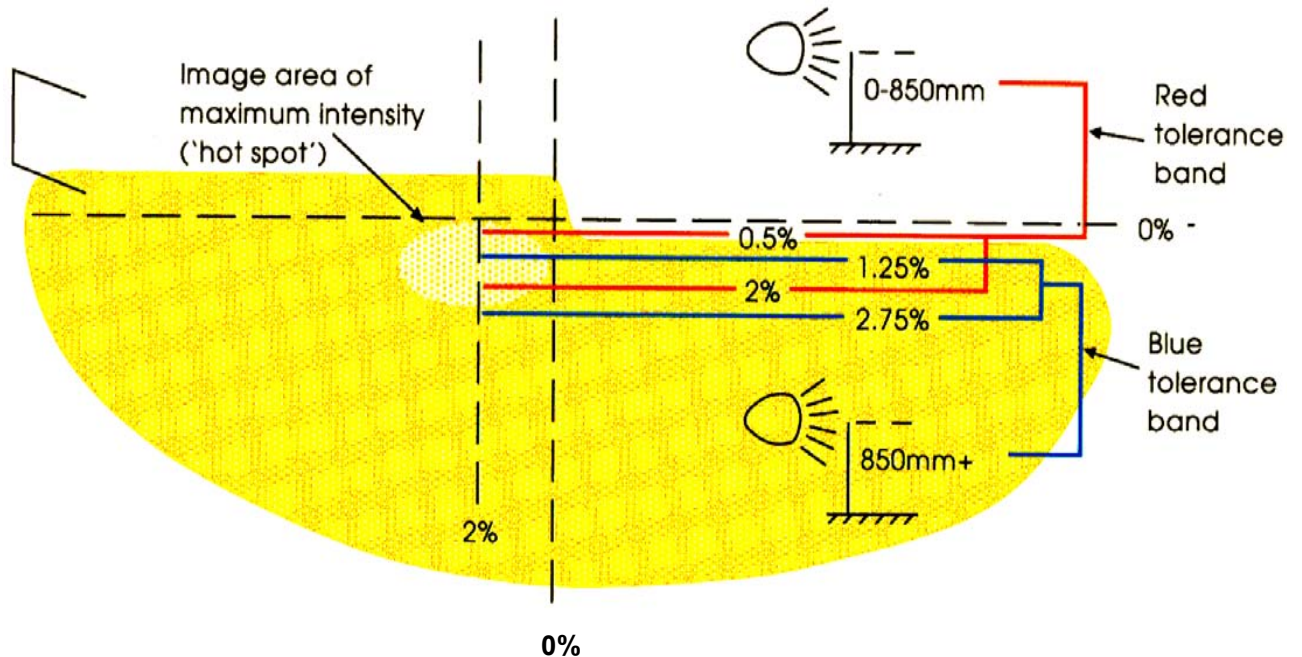

1.9 Electrical Wiring and Battery

Information	Method of Inspection	Reason for Rejection
<p>This inspection applies to all vehicles other than Class 3.</p> <p>Some tow bar electrical sockets are 'hidden' behind an access panel in the bumper or bodywork. Unless requiring the use of tools or specialist equipment, these panels must be removed to facilitate the inspection of the towbar socket.</p> <p>If a tow ball or pin is not fitted at the time of test, e.g. because it is detachable, has been unbolted or otherwise removed, but the attachment brackets are still in place, any trailer electrical socket should still be assessed.</p> <p>This does not apply if the attachment brackets have been deliberately rendered unfit for further use.</p> <p>A trailer electrical socket with a defective or missing cover flap that incorporates a lug and spring to hold the plug in place is not a Reason for Rejection.</p>	<ol style="list-style-type: none"> 1. Check the condition and security of the battery(ies). 2. Check the condition and security of all visible electrical wiring. 3. On vehicles fitted with a towbar, check the condition and security of the trailer electrical socket. Note: This check applies to both 7 pin (12N) and 13 pin electrical sockets. 4. On vehicles fitted with a towbar that have a trailer 13 pin Euro-socket, use an approved device to check that the socket is wired to correctly operate the trailer: <ul style="list-style-type: none"> • Position lamps • Stop lamps • Direction indicators • Rear fog lamp 	<ol style="list-style-type: none"> 1. A battery insecure or leaking electrolyte. 2. Electrical wiring: <ol style="list-style-type: none"> a. insecure or inadequately supported so that it is likely to become damaged b. damaged or deteriorated to the extent that it is likely to cause a short circuit or become detached c. insulation damaged or deteriorated to the extent that bare wiring or connectors are exposed. 3. A trailer electrical socket: <ol style="list-style-type: none"> a. insecure b. damaged or deteriorated to the extent that the connecting lead could not be securely connected. 4. A trailer 13 pin Euro-socket not operating the trailer lamps as intended.

Steering and Suspension

Section Contents

Sub-Section	Subject	Sub-Section	Subject
2.1	Steering Control	2.5	Front Suspension Front Wheel Bearings and Drive Shafts
2.2	Steering System		A. Suspension Joints and Wheel Bearings (Wheels jacked)
	A. Free Play		B. Suspension Joints (Wheels on turning plates)
	B. Play Under Load		C. Front Wheel Drive Shafts and Couplings
	C. Static Inspection	2.6	Rear Suspension and Wheel Bearings
	D. Lock to Lock Check	2.7	Shock Absorbers
2.3	Power Steering	2.8	Suspension Type Diagrams
2.4	Suspension – General		
	A. All Suspension Types		
	B. Leaf Springs		
	C. Coil Springs		
	D. Fluid/Gas/Air Suspension		
	E. Torsion Bars		
	F. Bonded Suspension Units		
	G. Suspension Arms and Linkages, Sub Frames etc		

2.1 Steering Control

Information	Method of Inspection	Reason for Rejection
<p>Before carrying out this inspection, make sure that any mechanism for adjusting the steering column is fully locked. Exert reasonable pressure only on the steering wheel, particularly when the steering column is collapsible.</p> <p>If power steering is fitted, the engine must be running for all checks requiring steering movement.</p> <p>To fully inspect some components it may be necessary to examine them from under-bonnet, underside or in the foot well area, using an inspection lamp and an assistant to operate the steering where necessary.</p> <p>For tricycles and quadricycles fitted with handlebars see Section 9.2.</p> <p style="text-align: right;">Cont'd ↓</p>	<p>Method of Inspection</p> <ol style="list-style-type: none"> 1. Check the strength and condition (including any modifications) of the steering wheel by applying reasonable force. 2. Push the steering wheel rim in various directions at right angles to the column, while applying light pressure downward and upward. Check for: <ol style="list-style-type: none"> a. insecurity of adjustable steering column b. movement between column shaft and steering wheel c. excessive play in top column bearing d. insecurity at column top mounting bracket. <p style="text-align: right;">Cont'd ↓</p>	<p>Reason for Rejection</p> <ol style="list-style-type: none"> 1. Steering wheel weakened by modification, cracks, fractures, in a condition that hampers proper control or likely to injure the driver's hands. <p>Note: Cracks or incompleteness of the covering skin of a steering wheel or hub, are not a reason for rejection.</p> 2. <ol style="list-style-type: none"> a. an adjustable steering column will not lock in a fixed position b. movement between the shaft and steering wheel c. excessive radial movement (play) at the top of the steering column between the column and the shaft indicating a badly worn top bearing <p>Note: Some vehicles have flexible top bearings for the steering column. With these more than average movement is acceptable.</p> d. insecurity at the steering column top mounting bracket. <p style="text-align: right;">Cont'd ↓</p>

2.1 Steering Control

Information	Method of Inspection	Reason for Rejection
<p>The inspection of the steering lock only applies to passenger cars with:</p> <ul style="list-style-type: none"> • a steering lock fitted as standard by the manufacturer, and • four or more wheels, and • not more than 8 passenger seats excluding the driver's seat, and • first used on or after 1 September 2001 <p>The check does not apply to quadricycles.</p> <p>If there is doubt as to whether a steering lock was originally fitted, the benefit of the doubt should be given.</p> <p>It is acceptable for a steering lock to be removed if there is an alternative, permanently installed, immobilisation device fitted which acts on either: the steering; gear shift; transmission; or prevents the engine from running.</p> <p>Some electronic steering locks, generally on vehicles with keyless ignition systems, will only activate when the driver's door is opened/closed.</p>	<ol style="list-style-type: none"> Pull and push the steering wheel in line with the column. Check for any movement at the centre of the steering wheel. <p>Note: Certain types of steering column (e.g. those fitted with universal joints or flexible couplings) may show some movement which is not due to excessive wear or deterioration.</p> <ol style="list-style-type: none"> With the engine running, turn the steering wheel clockwise and anti-clockwise and check that any steering lock mechanism does not engage remove the ignition key (if appropriate) and turn the steering wheel in either direction and check that the steering lock mechanism engages on vehicles with an electronic steering lock, check that a system malfunction warning is not displayed. Turn the steering wheel clockwise and anti-clockwise, checking steering column couplings and clamp bolts for security. Check the presence and security of retaining and locking devices. <p>Note: It is not always possible to determine the presence and effectiveness of certain types of locking devices e.g. locking fluid or 'nyloc' nuts.</p> 	<ol style="list-style-type: none"> Excessive steering shaft end float. <ol style="list-style-type: none"> A steering lock mechanism inadvertently engaging a steering lock mechanism missing or fails to engage an electronic steering lock system malfunction warning displayed. Insecurity, excessive play or deterioration of a flexible coupling or universal joint. A retaining or locking device missing or insecure.

2.2 Steering System

Information	Method of Inspection	Reason for Rejection
<p>This inspection applies to all types of steering mechanism.</p> <p>If power steering is fitted, the engine must be running for all checks requiring steering movement.</p> <p>If ATL or OPTL approved, references to the assistant's role in this section do not apply, although an NT may use an assistant to aid with the inspection of components if the NT considers it necessary.</p> <p>For tricycles and quadricycles with motorcycle derived steering/suspension systems, refer to Section 9.2.</p>	<p>A. Free Play</p> <p>1. With the road wheels on the ground pointing straight ahead, lightly turn the steering wheel left and right as far as possible without moving the road wheel.</p> <p>Check the amount of free play at the circumference of the steering wheel.</p> <p>Note: Play due to wear or maladjustment must not be confused with apparent play due to the construction of the mechanism, such as caused by the deflection of flexible joints or spring compression in external power steering systems.</p> <p>Note: The steering wheel free play limit is a general rule for standard diameter steering wheels, (380mm). Lower or higher limits should be set with larger or smaller diameter steering wheels.</p>	<p>1. A point on the rim of the steering wheel moves, without the road wheels moving, for more than:</p> <ul style="list-style-type: none">a. 75mm for non rack and pinionb. 13mm for rack and pinion steering. <p>Note: Where there are several joints between the steering wheel and the rack, movement up to 48mm on a 380mm diameter wheel may be accepted.</p>

2.2 Steering System

Information	Method of Inspection	Reason for Rejection
<p>It may be necessary to open the engine compartment to examine certain steering components on some vehicles (e.g. steering rack mounted on upper part of the bulkhead etc). If power steering is fitted:</p> <ul style="list-style-type: none"> the engine must be running, and care must be taken when inspecting components in the engine compartment. <p>Because dismantling is not permitted, it is accepted that visual examination of some components which are enclosed by protective gaiters will not be possible.</p> <p>Relative movement due to excessive wear MUST be distinguished from relative movement due to built-in clearance or spring loading of a joint.</p> <p>Bonded joints may show movement due to elasticity. Slight deterioration is acceptable.</p> <p>Play in ball joints or pivot points must not be regarded as excessive unless it is clear that replacement, repair or adjustment of the component is necessary.</p>	<p>B. Play Under Load</p> <p>1. With the front road wheels on the ground ask the assistant to rock the steering wheel in both directions firmly against resistance, examine the complete steering mechanism.</p> <p>Note: If ATL or OPTL approved; the wheel play detectors should be used in rotational mode for this inspection.</p> <p>Check for:</p> <ol style="list-style-type: none"> insecurity of any components relative movement between sector shaft and drop arm loose ball pin shanks loose track rod end or drag link ends weak or broken socket springs excessive play in ball joints excessive play at pivot points relative movement between the steering arm and its fixings <p style="text-align: right;">Cont'd ↓</p>	<p>1.</p> <ol style="list-style-type: none"> Insecurity of any part fixed to the vehicle structure, e.g. steering box, rack housing or intermediate drop arm pivot housing relative movement between the sector shaft and the drop arm a loose ball pin shank a loose track rod or drag link end a weak or broken socket spring excessive play in a ball joint excessive play in a pivot point (e.g. an intermediate drop arm) relative movement between a steering arm and its fixings <p style="text-align: right;">Cont'd ↓</p>

2.2 Steering System

	Method of Inspection	Reason for Rejection
	<p>i. the condition and security of rear wheel steering components, including front to rear connecting shafts</p> <p>j. if the rear wheel steering is inoperative, check:</p> <ul style="list-style-type: none">• the position of the rear wheels and• whether it affects the front wheel steering.	<p>i.</p> <ul style="list-style-type: none">• a rear wheel steering component insecure• excessive play in a rear wheel steering mechanism connection or ball joint• hydraulic fluid leaking from a rear wheel steering system <p>j. inoperative rear wheel steering where:</p> <ul style="list-style-type: none">• the rear wheels are not held substantially in the straight ahead position, or• the front wheel steering is adversely affected.

2.2 Steering System

Information	Method of Inspection	Reason for Rejection
<p>The inspections in this sub-section may be carried out at the same time as the inspections in sub-sections 2.2B and 2.2D.</p>	<p>C. Static Inspection</p> <p>1. With the road wheels on the ground and the steering wheel and system stationary.</p> <p>Check for:</p> <ul style="list-style-type: none"> a. wear in the neck of ball pins b. track rod or drag link ends misaligned c. condition of ball joint dust covers d. components fractured, cracked, damaged, excessively corroded or deformed e. inappropriate modification or repairs, especially by welding, or evidence that excessive heat has been applied, to steering components or structural members <p>Note: Methods of Inspection d and e also apply to rear wheel steering systems including front to rear connecting shafts.</p> <p style="text-align: right;">Cont'd ↓</p>	<p>1.</p> <ul style="list-style-type: none"> a. Sharp or deep grooves in the neck of a ball pin b. track rod or drag link ends seriously misaligned c. a ball joint dust cover missing, insecure or excessively damaged or deteriorated to the extent that it would no longer prevent the ingress of dirt etc. d. a component fractured, cracked, damaged, excessively corroded or deformed so that it is unserviceable e. inappropriate structural modification or repair by welding to a steering linkage component, or signs of excessive heat having been applied <p>Note: Reasons for Rejection d and e also apply to rear wheel steering. An inoperative rear wheel steering system is not a reason for rejection if:</p> <ul style="list-style-type: none"> • the rear wheels are held substantially in a straight ahead position • the front wheel steering is not adversely affected <p style="text-align: right;">Cont'd ↓</p>

2.2 Steering System

	Method of Inspection	Reason for Rejection
	<p>f. fluid leakage from a steering damper seal or gland</p> <p>g. the presence and security of retaining and locking devices</p> <p>Note: It is not always possible to determine the presence and effectiveness of certain types of locking devices e.g. locking fluid or 'nyloc' nuts.</p> <p>h. excessive corrosion, severe distortion or a fracture in the chassis or integral body attachment area of a main steering component e.g. steering box or rack, idler arm mounting, etc.</p>	<p>f. fluid leakage from a steering damper seal or gland to such an extent that it is clear that the seal or gland has failed</p> <p>g. a retaining or locking device missing or insecure</p> <p>h. deliberate modification which significantly reduces the original strength, excessive corrosion, severe distortion, a fracture or an inadequate repair of a load bearing member or its supporting structure or supporting panelling within 30cm of a steering component mounting, that is, within a 'prescribed area'. See Appendix C.</p>

2.2 Steering System

Information	Method of Inspection	Reason for Rejection
<p>This sub-section applies to all suspension types.</p> <p>It is important that these inspections are carried out:</p> <ul style="list-style-type: none"> with the suspension substantially in the normal running position on vehicles not fitted with a beam axle with the steered wheels resting on turning plates that move freely. <p>The use of turning plates is not mandatory for Class 5 vehicles but should be used if available and suitable.</p> <p>Vehicles with a beam axle can alternatively be raised from the ground as in Figure 1, Suspension Type Diagram, and this inspection carried out at the same time as the inspections in sub-section 2.5a.</p>	<p>D. Lock to Lock Check</p> <ol style="list-style-type: none"> With the front steered wheels resting on unlocked turning plates and using the steering wheel turn the steering from lock to lock and assess the steering system for any tightness or roughness in operation. With the front steered wheels resting on unlocked turning plates turn the wheels from lock to lock. <p>Check for:</p> <ol style="list-style-type: none"> fouling, particularly brake hoses brake hoses or brake pipes stretched or twisted presence, security and correct adjustment of lock stops if fitted <p>Note: Some vehicles have lock stops comprising rubbing pads on the body that the front tyres may contact on a full lock. These are acceptable if they are properly maintained so that they do not damage the tyres.</p> <ol style="list-style-type: none"> condition and security of steering rack gaiters <p>Note: Expand steering rack gaiters for proper examination.</p> <ol style="list-style-type: none"> oil leaking from steering box. 	<ol style="list-style-type: none"> Excessive tightness or roughness in the steering mechanism. <ol style="list-style-type: none"> A component of the steering mechanism, road wheels or tyres fouling any part of the vehicle a brake pipe or brake hose stretched, twisted or seriously damaged a steering lock stop: <ul style="list-style-type: none"> incorrectly adjusted missing, loose, damaged or insecurely locked <p>Note: A missing steering lock stop should only be failed where it is known to have been fitted as standard.</p> <ol style="list-style-type: none"> an insecure, split or missing steering rack gaiter a significant oil leak from the steering box.

2.3 Power Steering

Information	Method of Inspection	Reason for Rejection
<p>This sub-section applies to all types of power assisted steering systems.</p> <p>The inspection of all parts of steering linkage associated with the power steering mechanism is detailed in sub-sections 2.2B and 2.2C.</p> <p>Manually switched Electronic Park Assist designed to be activated when parking the vehicle is not a reason for rejection if the power assistance is inoperative provided the function of the steering is not adversely affected. It may be necessary to verify this by road testing.</p> <p>If power steering is optional fitment on the vehicle but has been disconnected in such a way that there is no adverse effect on the steering, that is not a Reason for Rejection. It may be necessary to verify this by road testing.</p> <p>Ensure the fluid has leaked from the power steering system and not from another source.</p> <p style="text-align: right;">Cont'd ↓</p>	<ol style="list-style-type: none"> 1. Where visible, check the power steering fluid level in the reservoir. 2. Check the condition of power steering pipes and hoses. 3. With the front road wheels on the ground, vehicle in neutral gear and the parking brake applied, run the engine and rock the steering wheel in both directions. Check: <ol style="list-style-type: none"> a. by feel at the steering wheel, that the system is operating b. for leaks in the system 4. In the case of external power systems check: <ol style="list-style-type: none"> a. the ram anchorages for cracks, damage and security to the frame or other fixed members of the vehicle b. the ram for cracks and/or damage c. for movement indicating wear at the anchorage point d. misalignment or fouling of components. <p style="text-align: right;">Cont'd ↓</p>	<ol style="list-style-type: none"> 1. Power steering fluid level below the minimum indication where this is shown. 2. A fluid pipe or hose excessively damaged, corroded or fouling on other parts of the vehicle. 3. <ol style="list-style-type: none"> a. Power steering malfunctioning or inoperative or evidence that power assistance has been removed or disconnected when it is known that power steering is standard on the vehicle b. a leak in the system showing that a component, joint or seal has failed 4. <ol style="list-style-type: none"> a. A cracked, insecure or excessively damaged ram anchorage b. a cracked or damaged ram body c. excessive free play at ram anchorage d. components fouling or significantly misaligned. <p style="text-align: right;">Cont'd ↓</p>

2.3 Power Steering

Information	Method of Inspection	Reason for Rejection
<p>If excessive free play is suspected during Mol 5, a further check should be made by applying manual effort to the ball-pin or ram body at right angles to the ram centre line.</p> <p>Reason for Rejection 8 does not apply to Class 3 vehicles.</p>	<ol style="list-style-type: none">5. With the engine stopped and steering wheel lightly rocked, check for excessive free play between ball-pin and valve.6. Where practicable, check the security of the power steering pump and the condition of its drive system.7. Check for any inappropriate repair or modification to power steering system components.8. Where electronic power steering is fitted, check that the Malfunction Indicator Lamp (MIL) does not indicate a failure in the system.	<ol style="list-style-type: none">5. Excessive free play between ball-pin and valve such that separation is likely.6. Pump insecure or its drive system missing or defective.7. An inappropriate repair or modification to a power steering component.8. An electronic power steering Malfunction Indicator Lamp indicates a failure in the system.

2.4 Suspension - General

Information	Method of Inspection	Reason for Rejection
<p>This sub-section applies to both front and rear suspensions including any optional components fitted.</p> <p>The inspections must be carried out with the vehicle over a pit or on a raised lift.</p> <p>The examination of some front suspension components requires the steered wheels to be jacked up as described in Section 2.5, MOI A1 and the examination of some rear suspension components require the rear wheels to be jacked as described in Section 2.6.</p> <p>A small pinch bar should be used to check for wear or play in many of the suspension components covered in this section.</p> <p>Guidance for assessing corrosion and the use of the Corrosion Assessment Tool is given at Appendix C.</p> <p>The condition of the vehicle main load bearing structure not in a 'prescribed area' is checked under Section 6.</p> <p>A suspension bump stop must not be confused with rubber/synthetic suspension spring assistors.</p> <p>An inappropriate repair or modification includes welded repairs or the use of excessive heat to highly stressed components (see Appendix C) and modifications which are likely to affect the roadworthiness of the vehicle.</p> <p>Tricycle and quadricycle requirements are detailed at Section 9.2.</p>	<p>A. All Suspension Types</p> <ol style="list-style-type: none">1. Check:<ol style="list-style-type: none">a. that there is enough clearance of the axle or suspension with the bump stop or chassisb. whether any suspension unit is so weak that it does not hold the body far enough away from the road wheels.2. Check all suspension components for inappropriate repairs or modifications.3. Examine the vehicle structure around any sub-frame, spring or suspension component mounting for:<ul style="list-style-type: none">• excessive corrosion (i.e. within the 'prescribed area', see Appendix C)• distortion• fractures. <p>Note: It is usually necessary to open the bonnet to inspect front suspension components. It may be necessary to inspect the inside of a luggage compartment or boot to effectively check prescribed areas and testable items that otherwise would not be seen.</p>	<ol style="list-style-type: none">1.<ol style="list-style-type: none">a. Inadequate clearance of the axle or suspension with the bump stop or chassisb. a suspension unit so weak that the body or other part of the vehicle fouls a road wheel or would do so if the vehicle was laden.<p>Note: a missing bump stop rubber is not a reason for rejection.</p>2. A suspension component with an inappropriate repair, or a modification which has seriously weakened the component.3. Deliberate modification which significantly reduces the original strength, excessive corrosion, severe distortion, a fracture or an inadequate repair of a load bearing member or its supporting structure or supporting panelling within 30cm of any sub-frame, spring or a suspension component mounting, that is, within a 'prescribed area', see Appendix C.

2.4 Suspension - General

Information	Method of Inspection	Reason for Rejection
<p>Reason for Rejection 1.a. also applies to that part of a leaf which is curled to prevent disengagement from a slipper.</p> <p style="text-align: right;">Cont'd ↓</p>	<p>B. Leaf Springs</p> <ol style="list-style-type: none">1. Examine each leaf spring assembly, check:<ol style="list-style-type: none">a. the condition of spring leavesb. the condition of spring eyesc. the lateral location of spring leaves (particularly leaf splay)d. leaves for longitudinal displacemente. the correct location of the springs to the axle for symmetry.2. Check the security and the amount of play at the spring anchor bracket pin/bush and both pins/bushes of the spring shackle. <p style="text-align: right;">Cont'd ↓</p>	<ol style="list-style-type: none">1.<ol style="list-style-type: none">a. A cracked or fractured leaf, or one which is permanently distorted due to damage or so deteriorated that it is seriously weakenedb. a defective spring eyec. the leaves of a multi-leaf spring splayed to such an extent that the action of the spring is impaired, or will foul other parts of the vehicled. a spring leaf longitudinally displacede. a spring so fitted that the axle is misaligned.2. Excessive wear in a pin and/or bush, for example more than:<ul style="list-style-type: none">• 2mm for a 12mm diameter pin• 3mm for a 25mm diameter pin• 10% of the pin diameter for pins over 25mm diameter• deterioration of a rubber bush resulting in excessive movement. <p style="text-align: right;">Cont'd ↓</p>

2.4 Suspension - General

Information	Method of Inspection	Reason for Rejection
<p>Attachment of suspension units, e.g. anchor brackets, may be by bolts, nuts, rivets, welding etc. When modified spring anchor or shackle brackets are fitted, there may be more holes in the bracket than holes in the chassis. This is not a reason for rejection.</p>	<p>3. Check that:</p> <ul style="list-style-type: none"> a. anchor/shackle pins are correctly positioned and secure b. retaining and any locking devices are present and secure. <p>Note: It is not always possible to determine the presence and effectiveness of certain types of locking devices e.g. locking fluid or 'nyloc' nuts.</p> <p>4. Check the side play at spring eyes.</p> <p>Note: For normal leaf suspension, side play at the spring eye should not exceed 6mm.</p> <p>5. Check condition of slipper and rebound pin.</p> <p>6. Check that the spring balance beam, anchor and shackle brackets are:</p> <ul style="list-style-type: none"> a. secure and free from signs of movement b. free from cracks or fractures c. complete with all nuts, bolts and rivets d. free from excessive damage or corrosion. <p>Note: Damage includes damage by weld, e.g. weld blow holes or cuts which seriously weaken the component.</p> <p>7. Check the security of spring and saddle to the axle.</p>	<p>3. A shackle, anchor or linkage pin:</p> <ul style="list-style-type: none"> a. missing, not correctly positioned or excessively loose in its bracket b. retaining or locking device, missing or insecurely fitted. <p>4. Excessive side play at spring eye.</p> <p>5. A slipper excessively worn, cracked, insecure or its rebound pin missing.</p> <p>6. An anchor or shackle bracket:</p> <ul style="list-style-type: none"> a. loose to chassis b. cracked or fractured c. with a nut, bolt or rivet missing d. damaged or corroded so that it is seriously weakened. <p>7.</p> <ul style="list-style-type: none"> a. Evidence that a spring saddle is fractured or moving relative to the spring b. a nut or bolt securing the spring to the axle not secure or missing.

2.4 Suspension - General

Information	Method of Inspection	Reason for Rejection
<p>Shortened coil springs, to lower the ride height, are acceptable provided the spring ends locate correctly when the vehicle is returned to the normal running position without assistance.</p> <p>Where such springs are fitted, extra vigilance may be necessary when checking that the tyres and other components do not foul, especially during the lock to lock check.</p>	<p>C. Coil Springs</p> <ol style="list-style-type: none">1. Check the condition of each coil spring. 2. Check that both ends of the spring are correctly located. 3. Check that the spring mountings are:<ol style="list-style-type: none">a. secureb. free from cracks and fracturesc. free from excessive damage or corrosion.	<ol style="list-style-type: none">1. A coil spring:<ol style="list-style-type: none">a. broken or fracturedb. worn or so corroded its cross sectional area is reduced such that it is seriously weakened. 2. A coil spring not correctly located. 3. A coil spring mounting:<ol style="list-style-type: none">a. looseb. cracked or fracturedc. seriously weakened by damage or corrosion.

2.4 Suspension - General

Information	Method of Inspection	Reason for Rejection
<p>Care must be taken not to cause damage to body work when pushing down on the suspension.</p>	<p>D. Fluid/Gas/Air Suspension</p> <ol style="list-style-type: none">1. Check suspension units and accumulators for:<ol style="list-style-type: none">a. displacementb. damage or serious deteriorationc. fouling by moving parts.2. Check for any leak in the system.3. Check suspension units' supply pipes or interconnecting pipes for security, damage or corrosion.4. Check the security of levelling valves.5. At each corner of the vehicle, where practicable, push down (or pull down from underneath), and note the amount of suspension movement.	<ol style="list-style-type: none">1. A suspension unit or accumulator:<ol style="list-style-type: none">a. displaced or totally deflatedb. damaged or deteriorated so that it is likely to failc. fouled by moving parts likely to cause damage or restrict travel.2. A leak in the system.3. A suspension unit supply pipe or interconnecting pipe insecure, damaged or corroded so that it is seriously weakened.4. An insecure levelling valve.5. No suspension movement. <p>Note: Large vehicle suspensions can be difficult to move. Ensure there is a defect before rejection.</p>

2.4 Suspension - General

Method of Inspection	Reason for Rejection
<p>E. Torsion Bars</p> <ol style="list-style-type: none">1. Examine the bars for:<ol style="list-style-type: none">a. cracks and fracturesb. excessive corrosion and pitting.2. Check the end fixings for:<ol style="list-style-type: none">a. securityb. excessive free play.3. Examine the adjustment assemblies for security.4. Check that the attachments of bars are:<ol style="list-style-type: none">a. secure to frame and suspensionb. free from cracks or fracturesc. free from excessive damage or corrosion.	<ol style="list-style-type: none">1. A torsion bar:<ol style="list-style-type: none">a. cracked or fracturedb. deteriorated by corrosion or pitting so that its cross sectional area is reduced and seriously weakened.2. Insecurity or excessive play at an end fixing.3. Adjustment assembly inadequately locked.4. A torsion bar attachment bracket:<ol style="list-style-type: none">a. looseb. cracked or fracturedc. seriously weakened by damage or corrosion.

2.4 Suspension - General

Information	Method of Inspection	Reason for Rejection
<p>This inspection applies to bonded suspension spring units i.e. rubber cone suspension. Bonded mountings and bushes are to be inspected in accordance with sub-section 2.4G.</p>	<p>F. Bonded Suspension Units</p> <ol style="list-style-type: none">1. Check that the attachments of units are:<ol style="list-style-type: none">a. secureb. free from cracks and fracturesc. free from excessive damage or corrosion.2. Examine the bonding of the flexible element to its associated metal fixing.3. Check the general condition of the unit for damage and deterioration of the flexible element.	<ol style="list-style-type: none">1. A bonded unit attachment:<ol style="list-style-type: none">a. looseb. cracked or fracturedc. seriously weakened by damage or corrosion.2. Failure of the bonding between flexible element and the metal so that part of the unit is likely to become displaced.3. The unit is so damaged or deteriorated that it is no longer capable of carrying out its proper function.

2.4 Suspension - General

Information	Method of Inspection	Reason for Rejection
<p>The inspections in sub-section 2.4G can be carried out in conjunction with the inspections in:</p> <ul style="list-style-type: none">sub-section 2.5 (Front Suspension, Wheel Bearings and Drive Shafts), andsub-section 2.6 (Rear Suspension and Wheel Bearings). <p>Some vehicles use comparatively thin gauge steel pressings for some highly stressed suspension components.</p> <p>Many of these parts have hollow 'box sections' or upfacing areas where road dirt impregnated with salt or other chemicals collects and causes serious but often very local corrosion.</p> <p>Special attention should be paid to these components. See Appendix C for further guidance.</p>	<p>G. Suspension Arms and Linkages, Sub-Frames, etc</p> <ol style="list-style-type: none">1. Check the following components and any attachment brackets or linkages, for presence, cracks, fractures, distortion, corrosion, wear and insecurity:<ol style="list-style-type: none">a. suspension arms (wishbone etc)b. trailing armsc. radius armsd. tie bars/rodse. panhard rodsf. torque/reaction armsg. anti-roll barsh. MacPherson strutsi. sub-frames.	<ol style="list-style-type: none">1. A suspension component or its attachment bracket or linkage:<ul style="list-style-type: none">• missing where one is fitted as standard• cracked, fractured or insecure• weld cracked• severely distorted• damaged, corroded or worn to such an extent that its strength is seriously reduced• retaining nut, bolt or rivet missing• which is adjustable and is loose in its adjustment threads, or its locking device insecure or missing. <p>Note: It is not always possible to determine the presence and effectiveness of certain types of locking devices e.g. locking fluid or 'nyloc' nuts.</p>

Cont'd ↓

Cont'd ↓

2.4 Suspension - General

Information	Method of Inspection	Reason for Rejection
<p>Some rubber/synthetic bushes are designed to provide a comparatively high degree of compliance and are therefore likely to show some movement.</p> <p>Such components should normally only be rejected when serious deterioration of the bonding or flexible material is evident.</p>	<ol style="list-style-type: none"> 2. Check the security and condition of pins/bushes/mountings and ball joints locating: <ol style="list-style-type: none"> a. upper and lower suspension arms/wishbones b. trailing arms c. radius arms d. tie-bars/rods e. panhard rods f. torque/reaction arms g. anti-roll bars and linkages h. sub-frames. 3. Check that: <ol style="list-style-type: none"> a. linkage pins are correctly positioned and secure b. retaining and any locking devices are fitted and secure. <p style="text-align: right;">Cont'd ↓</p>	<ol style="list-style-type: none"> 2. <ul style="list-style-type: none"> • Excessive play in a pin/bush or pin/bearing, for example more than: <ul style="list-style-type: none"> – 2mm for a 12mm diameter pin – 3mm for a 25mm diameter pin – 10% of the diameter for pins over 25mm diameter • excessive play in ball joint • a ball joint dust cover missing or excessively damaged, deteriorated or insecure to the extent that it would no longer prevent the ingress of dirt etc. • deterioration of a rubber, synthetic bush or mounting resulting in excessive movement • deterioration of the bonding of a rubber bush/mounting resulting in excessive movement. 3. A suspension link locating pin: <ol style="list-style-type: none"> a. incorrectly positioned or insecure b. retaining or locking device missing or not properly locked. <p style="text-align: right;">Cont'd ↓</p>

Method of Inspection	Reason for Rejection
<p>4. On vehicles which have a drive shaft which forms part of the suspension, check:</p> <ul style="list-style-type: none">a. the shaft for distortion, damage and serious corrosionb. for excessive play in a universal jointc. the flanges and bolts for presence and securityd. for wear in drive shaft support bearingse. the condition and security of drive shaft coupling gaiters.	<p>4.</p> <ul style="list-style-type: none">a. Distorted, damaged or excessively corroded drive shaftb. excessive play in a universal jointc. a universal joint:<ul style="list-style-type: none">• flange incorrectly seated• flange bolt loose, missing or inadequately lockedd. a drive shaft support bearing excessively worne. a drive shaft coupling gaiter missing or excessively damaged, deteriorated or insecure to the extent that it would no longer prevent the ingress of dirt etc.

2.5 Front Suspension, Wheel Bearings and Drive Shafts

Information	Method of Inspection	Reason for Rejection
<p>The inspections under this sub-section must be carried out with the vehicle over a pit or on a raised lift.</p> <p>For many of these inspections an assistant must be used unless the test bay is ATL or OPTL approved. In these circumstances, an NT may still elect to use an assistant to aid with the inspection of components.</p> <p>The inspection of front suspension components described in sub-section 2.4G, suspension arms and linkages, sub-frames etc, can be carried out in conjunction with this sub-section.</p> <p>Vehicles with suspension types as shown in Diagram figure 2 and 2a must be jacked so that the suspension spring force is removed from the ball joints, i.e. suspension arms must be clear of their stops. Failure to do this can result in defective joints being overlooked.</p> <p style="text-align: right;">Cont'd ↓</p>	<p>A. Suspension Joints and Wheel Bearings (wheels jacked)</p> <p>1. See the VSI or Suspension Type Diagram for the jacking positions of various suspension types.</p> <p>Jack up the front of the vehicle so that the front wheels are clear of the ground, observing relative vertical movement between components.</p> <p>Carry out the following examinations by placing a suitable bar under each wheel in turn and levering upwards.</p> <p>a. For suspension types on Suspension Type Diagram fig 1, check for excessive vertical movement between stub axles and axle beams</p> <p>b. For suspension types on Suspension Type diagram fig 2 and 2a, check for vertical movement between swivel and housing, and movement in wishbone bearings.</p> <p>c. For suspension types as Suspension Type Diagram figs 3, 3a and 4, check for movement in suspension ball joints, tie bar joints and MacPherson strut upper attachment. If ATL or OPTL approved; this inspection is carried out on wheel play detectors in side to side mode</p> <p>Repeat Mols a, b and c above using the assistant to place a suitable bar under each wheel in turn and levering upwards while the tester examines the relevant items.</p> <p style="text-align: right;">Cont'd ↓</p>	<p>1. Excessive movement:</p> <p>a. between a stub axle and an axle beam</p> <p>Note: Some vehicles (especially with ball thrust races) are designed to have a small amount of vertical movement.</p> <p>b. between a swivel joint and its housing</p> <p>c.</p> <ul style="list-style-type: none"> • at a suspension ball joint, tie bar joint, wishbone bearing, pin or bush • at a MacPherson strut upper attachment. <p>Note: Some MacPherson strut top bushes are designed to have lateral play when the suspension is hanging free. Rejection is only justified when play is due to wear and/or maladjustment, etc.</p> <p style="text-align: right;">Cont'd ↓</p>

2.5 Front Suspension, Wheel Bearings and Drive Shafts

Information	Method of Inspection	Reason for Rejection
<p>Reason for Rejection 2 does not apply to a vehicle where it is not possible to rotate the wheel due to a design characteristic or its drive configuration.</p> <p>It is not possible to lay down precise king pin/bush wear limits but the following may be helpful as a guide in determining acceptable wear at king pins.</p> <p>With the wheel braked, note the total amount of movement at the wheel rim when the wheel is rocked. For a 50cm wheel this should not exceed 10mm. The maximum for other wheel diameters should be in proportion to this figure.</p>	<ol style="list-style-type: none"> 2. With the steered wheels clear of the ground, rotate each wheel in turn and listen for any sound indicating roughness in the bearing. 3. Rock each wheel by hand or, where appropriate, with a bar in the wheel. (This inspection may alternatively be carried out using approved wheel play detectors in the “side-to-side” mode.) <p>Check:</p> <ol style="list-style-type: none"> a. the amount of movement between the stub axle and the axle beam, or b. the movement in the swivel joints, and the security of their attachment to the stub axle and suspension arms c. the movement of the wheel relative to the stub axle, and note the amount of play in the wheel bearings. <p>Repeat Methods of Inspection a, b and c above using the assistant to rock the wheel by hand or where appropriate with a bar in the wheel while the tester examines the relevant items.</p> <p style="text-align: right;">Cont'd ↓</p>	<ol style="list-style-type: none"> 2. Roughness in a front wheel bearing. 3. <ol style="list-style-type: none"> a. <ul style="list-style-type: none"> • King pin loose in axle beam or its pin retaining device missing • excessive play in king pin and/or bush such that it is likely to adversely affect the steering of the vehicle b. <ul style="list-style-type: none"> • excessive play in swivel joint • excessive play in any suspension swivel pin or suspension ball joint • a swivel joint insecure in a suspension arm or in a stub axle c. excessive play in a front wheel bearing. <p style="text-align: right;">Cont'd ↓</p>

2.5 Front Suspension, Wheel Bearings and Drive Shafts

Method of Inspection	Reason for Rejection
<p>4. Check the presence and effectiveness of front suspension retaining and locking devices.</p> <p>Note: It is not always possible to determine the presence and effectiveness of certain types of locking devices e.g. locking fluid or 'nyloc' nuts.</p> <p>5. Check the condition of the axle beam and stub axles.</p>	<p>4. A front suspension retaining or locking device missing or ineffective.</p> <p>5. An axle beam or stub axle:</p> <ul style="list-style-type: none">a. crackedb. excessively distorted

2.5 Front Suspension, Wheel Bearings and Drive Shafts

Information	Method of Inspection	Reason for Rejection
<p>If ATL or OPTL approved this inspection is carried out on wheel play detectors in side-to-side mode.</p> <p>On non-ATL / OPTL approved bays, the wheels must also be rocked and shaken by the assistant while the tester examines the relevant items.</p>	<p>B. Suspension Joints (wheels on turning plates or on wheel play detectors if ATL or OPTL approved)</p> <p>For vehicles with suspension types as shown in Suspension Type Diagram figs 3, 3a and 4, lower the front wheels so that they:</p> <ul style="list-style-type: none"> ▪ bear the weight of the vehicle, and ▪ are resting on turning plates which enable the wheels to be turned freely lock to lock, or ▪ if ATL or OPTL approved resting on wheel play detectors. <p>Inspect as follows:</p> <ol style="list-style-type: none"> 1. Grasp the top of each front wheel and rock it vigorously in and out to check for play: <ol style="list-style-type: none"> a. in the upper and lower suspension ball joints and wishbone bearings b. at MacPherson strut: <ul style="list-style-type: none"> • sliding bushes and glands • upper support bearings. <p style="text-align: right;">Cont'd ↓</p>	<ol style="list-style-type: none"> 1. <ol style="list-style-type: none"> a. <ul style="list-style-type: none"> • Excessive play in a suspension ball joint • a ball joint securing nut loose or not locked • excessive play in an upper or lower wishbone inner bearing, pin or bush (cross check with sub section 2.4G Mol 3) b. <ul style="list-style-type: none"> • excessive play in a MacPherson strut sliding bush or gland • excessive movement in a MacPherson strut upper support bearing assembly. <p style="text-align: right;">Cont'd ↓</p>

2.5 Front Suspension, Wheel Bearings and Drive Shafts

	Method of Inspection	Reason for Rejection
	<ul style="list-style-type: none">2. Grasp each front wheel at 3 o'clock and 9 o'clock, and shake vigorously to determine the condition of the outer ball joints and track control arm inner bushes. 3. Examine the condition of the bonding between the metal and flexible material in the MacPherson strut upper support bearing, if visible.	<ul style="list-style-type: none">2.<ul style="list-style-type: none">a. Excessive play in an outer ball jointb. excessive play in a track control arm inner bush. 3.<ul style="list-style-type: none">a. Serious deterioration of the bonding between metal and flexible material of an upper support bearingb. a loose or insecurely locked unit in the upper support bearing assembly.

2.5 Front Suspension, Wheel Bearings and Drive Shafts

Method of Inspection	Reason for Rejection
<p data-bbox="730 261 1310 293">C. Front Wheel Drive Shafts and Couplings</p> <p data-bbox="779 310 1318 370">Inspect as follows while the front wheels are jacked up.</p> <ol data-bbox="730 386 1360 1219" style="list-style-type: none"><li data-bbox="730 386 1360 516">1. With the vehicle in neutral gear, rotate the wheels when they are on each lock in turn, and check visually the gaiters of the constant velocity joints while the pleats are expanded. <li data-bbox="730 987 1360 1219">2. Check:<ol data-bbox="779 1036 1360 1219" style="list-style-type: none"><li data-bbox="779 1036 1360 1096">a. the front wheel drive shafts for straightness and damage<li data-bbox="779 1112 1360 1144">b. drive shaft couplings' condition and security<li data-bbox="779 1187 1360 1219">c. for wear in drive shaft support bearings.	<ol data-bbox="1396 386 2032 1247" style="list-style-type: none"><li data-bbox="1396 386 2032 954">1.<ol data-bbox="1444 418 2032 954" style="list-style-type: none"><li data-bbox="1444 418 2032 548">a. A constant velocity joint gaiter missing or excessively damaged, deteriorated or insecure to the extent that it would no longer prevent the ingress of dirt etc.<li data-bbox="1444 565 2032 625">b. a drive shaft constant velocity joint excessively worn or insecure<li data-bbox="1444 641 2032 701">c. a drive shaft coupling excessively worn or insecure<li data-bbox="1444 717 2032 815">d. a drive shaft flexible rubber or fabric coupling unit severely cracked or breaking up<li data-bbox="1444 831 2032 954">e. a drive shaft flexible rubber or fabric coupling softened by oil contamination, insecure or fouling any other part of the vehicle. <li data-bbox="1396 987 2032 1247">2.<ol data-bbox="1444 1036 2032 1247" style="list-style-type: none"><li data-bbox="1444 1036 2032 1068">a. A drive shaft bent or damaged<li data-bbox="1444 1117 2032 1177">b. an insecure or fractured fastener securing a drive shaft coupling bearing<li data-bbox="1444 1193 2032 1247">c. a drive shaft support bearing excessively worn.

2.6 Rear Suspension and Wheel Bearings

Information	Method of Inspection	Reason for Rejection
<p>This inspection applies to all vehicles except Class 5 or Class 4 with a DGW in excess of 5000kg.</p> <p>The checks in this sub-section must be carried out:</p> <ul style="list-style-type: none">• with the vehicle over a pit or on a raised lift, and• the rear of the vehicle jacked up so that ideally the suspension hangs freely with both wheels clear of the ground. <p>Other testable items may be more easily examined while the vehicle is jacked, particularly when the rear suspension is hanging freely.</p> <p>Reason for Rejection 1 does not apply to a vehicle where it is not possible to rotate the wheel due to a design characteristic or its drive configuration.</p>	<ol style="list-style-type: none">1. Rotate each wheel in turn and listen for any sound indicating roughness in the bearing.2. Rock each wheel by hand or when appropriate with a bar in the wheel, and check the movement of the wheel relative to the axle to assess the amount of play in the wheel bearings. <p>Note: It may be an advantage to use an assistant when carrying out this check.</p>	<ol style="list-style-type: none">1. Excessive roughness in a rear wheel bearing.2. Excessive play in a rear wheel bearing, indicating severe maladjustment or wear.

2.7 Shock Absorbers

Information	Method of Inspection	Reason for Rejection
<p>Before failing a leaking shock absorber, ensure that any fluid near the unit is from the shock absorber and not from another source.</p> <p>Slight seepage causing a film of fluid on a shock absorber is not a reason for rejection.</p>	<ol style="list-style-type: none">1. Check for the presence of shock absorbers where these are a standard item.2. Examine each shock absorber for damage, corrosion and security of attachment. Note: For shock absorbers incorporated in MacPherson struts, inspect in conjunction with items under sub-section 2.5.3. Examine each shock absorber for fluid leaks.4. Examine the condition of any linkages, pivots or rubber bushes.	<ol style="list-style-type: none">1.<ol style="list-style-type: none">a. No shock absorbers fitted to a vehicle on which they are known to be fitted as standardb. a shock absorber missing.2.<ol style="list-style-type: none">a. External damage or corrosion to the casing of a shock absorber so that the unit does not functionb. an insecure or detached shock absorber.3. A fluid leakage serious enough to indicate that the fluid seal of a shock absorber has failed.4. An excessively worn shock absorber linkage, pivot or bush.

2.8 Suspension Type Diagrams

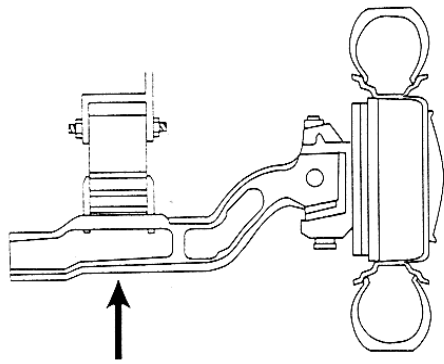

Figure 1

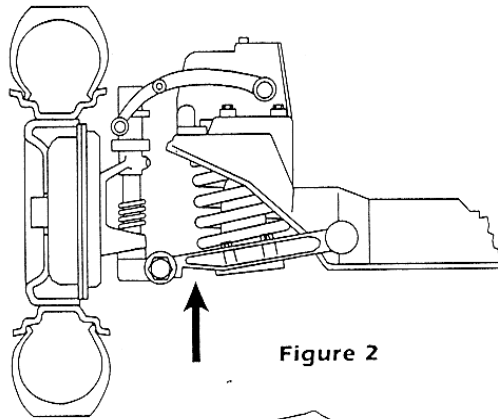

Figure 2

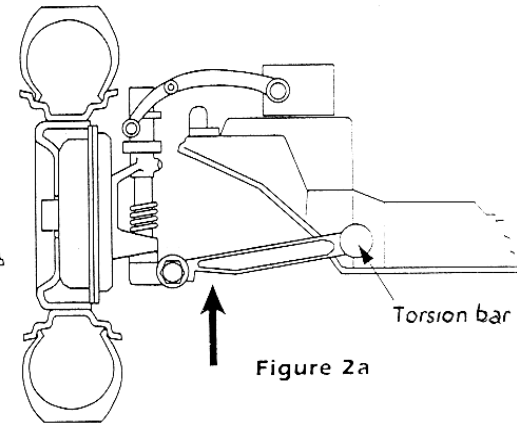

Figure 2a

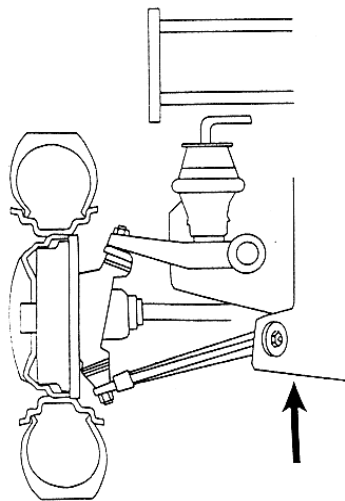

Figure 3

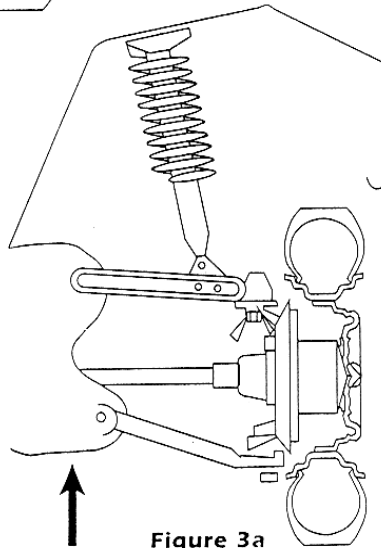

Figure 3a

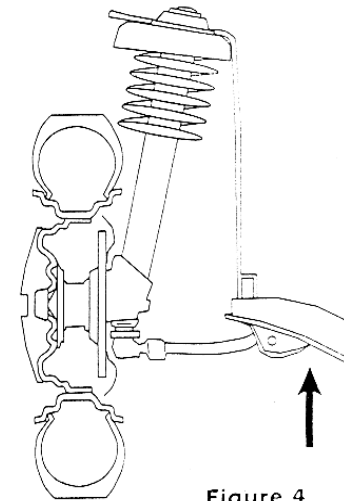

Figure 4

Brakes

Section Contents

Sub-Section	Subject	Sub-Section	Subject
3.1	Parking Brake Control	3.6	E. Valves
3.2	Hand Operated Brake Control Valves		F. Pumps and Compressors
3.3	Service Brake Control		G. Hydraulic Systems
	A. All Types of Braking Systems		H. Air Systems
	B. Hydraulic Systems (including servo assisted)		I. Additional Braking Devices
	C. Vehicles with High Servo Boost		J. Electronic Braking Systems (Class 5 only)
	D. Full Power Hydraulic Braking Systems	3.7	Brake Performance
	E. Air and Vacuum Systems (including over hydraulic)		A. Roller Brake Test
3.4	Anti-Lock Braking and Electronic Stability Control Systems		B. Decelerometer Test
3.5	Mechanical Brake Components		C. Plate Brake Test
3.6	Braking Systems and Additional Braking Devices		D. Gradient Test
	A. All Braking Systems	3.8	Method of Calculating Brake Performance
	B. Brake Pipes and Flexible Hoses	3.9	Example of a Manufacturers' Plate
	C. Servos and Master Cylinders	3.10	Brake Efficiency Tables
	D. Reservoirs (Air/Vacuum) (including accumulators, pressure and vacuum vessels)		

3.1 Parking Brake Control

Information	Method of Inspection	Reason for Rejection
<p>Many of the checks in this sub-section are based on the assumption that the parking brake is a ratchet type hand lever. For vehicles with foot-operated or electronic parking brakes the “Method of Inspection” detailed will need to be ignored or varied depending on the particular type.</p> <p>Vehicles certified as being designed before 1 January 1905 and constructed before 31 December 1905 do not require a parking brake.</p> <p>Hydraulic parking brakes as a sole means of operation are not acceptable on vehicles first used on or after 1 January 1968. However, they may be used to assist the application or release of a mechanical brake.</p> <p>An electronic parking brake (EPB), although applied electronically, must be maintained in operation by direct mechanical means. This mechanism may be within the brake caliper or within the motor/gear assembly, so cannot be readily seen.</p> <p>Items not possible to check fully from the driver’s seat should be checked from beneath the vehicle and/or under the bonnet.</p> <p style="text-align: right;">Cont’d ↓</p>	<ol style="list-style-type: none"> 1. Check that the vehicle has a parking brake designed to prevent: <ul style="list-style-type: none"> • at least two wheels from turning, or • with a three-wheeled vehicle, at least one wheel from turning. 2. Check the method of operation. 3. While sitting in the driver’s seat, check the presence, security and condition of the parking brake lever or control. 4. With the brake lever in the “off” position: <ol style="list-style-type: none"> a. check the amount of side play in the lever pivot by moving the lever from side to side <p>Note: Some vehicles have sideways movement of the parking brake lever when new. Movement is a reason for rejection only when:</p> <ul style="list-style-type: none"> • the pawl is moved clear of the ratchet, and • the brake does not hold in the ‘on’ position <ol style="list-style-type: none"> b. check the security of the lever and pawl mechanism pivots, their associated mountings and the presence and effectiveness of retaining and locking devices. <p style="text-align: right;">Cont’d ↓</p>	<ol style="list-style-type: none"> 1. The vehicle does not have a parking brake designed to prevent: <ul style="list-style-type: none"> • at least two wheels from turning • with a three-wheeled vehicle, at least one wheel from turning. 2. For vehicles first used on or after 1 January 1968 the parking brake is not capable of being maintained in operation by direct mechanical action only. 3. The brake lever or control: <ol style="list-style-type: none"> a. missing b. insecure c. defective or located so that it cannot be satisfactorily operated. 4. <ol style="list-style-type: none"> a. Side play in the brake lever pivot to the extent that the pawl may inadvertently disengage b. the lever or pawl mechanism pivots and their associated mountings are insecure or a locking or retaining device is insecure or missing. <p style="text-align: right;">Cont’d ↓</p>

3.1 Parking Brake Control

Information	Method of Inspection	Reason for Rejection
<p>An Electronic Parking Brake (EPB) may apply automatically in certain conditions e.g. such as when the driver's door is opened. Testers should be aware of this throughout various aspects of the test.</p> <p>Reason for Rejection 7 does not apply to Class 3 vehicles.</p>	<ol style="list-style-type: none"> 5. Without operating the pawl mechanism, apply the parking brake slowly and check the effective operation of the pawl mechanism by listening for definite and regular clicks as the pawl moves over the ratchet teeth. 6. When the brake is fully applied: <ol style="list-style-type: none"> a. knock the top and each side of the lever and check that the lever stays in the "on" position b. check that the lever is not at the end of its working travel and that there is no fouling of adjacent parts c. check that the lever is not impeded in its travel. 7. On vehicles with an electronic parking brake, operate the switch to release and apply the parking brake and check that a malfunction is not indicated. 8. Check the parking brake lever or control for any inappropriate repair or modification. <p style="text-align: right;">Cont'd ↓</p>	<ol style="list-style-type: none"> 5. The pawl spring is not pushing the pawl positively into the ratchet teeth or the ratchet has broken, or excessively worn teeth. 6. <ol style="list-style-type: none"> a. When knocked, the lever is not held in the "on" position b. when the brake is fully applied there is no possibility of further travel of the lever because the lever is: <ul style="list-style-type: none"> • at the end of its working travel on the ratchet, or • fouling adjacent parts of the vehicle c. the lever is impeded in its travel. 7. Electronic parking brake warning indicates a malfunction. <p>Note: An EPB malfunction may alternatively be indicated by a message on the dashboard.</p> 8. A parking brake lever or control inappropriately repaired or modified. <p style="text-align: right;">Cont'd ↓</p>

3.1 Parking Brake Control

	Method of Inspection	Reason for Rejection
	<p>9. Check the condition of the vehicle structure around the mountings of any:</p> <ul style="list-style-type: none">a. mechanical parking brake lever mechanismb. electro-mechanical actuator unit. <p>Note: It may be necessary to check the mounting of the parking brake lever or EPB electro-mechanical actuator unit 'prescribed areas' from the vehicle underside when it cannot be checked from the inside the cabin.</p>	<p>9. Deliberate modification which significantly reduces the original strength, excessive corrosion, severe distortion, a fracture or an inadequate repair of a load bearing member or its supporting structure or supporting panelling within 30cm of the parking brake mechanism or associated mounting(s), that is, within a 'prescribed area', see Appendix C.</p>

3.2 Hand Operated Brake Control Valves

Information	Method of Inspection	Reason for Rejection
<p>This inspection applies to all vehicles with a secondary brake operating mechanism in addition to, or in place of, the normal parking brake lever.</p> <p>This Includes hand operated valves fitted to control spring brakes or lock actuators.</p>	<ol style="list-style-type: none"> 1. Examine the control for: <ol style="list-style-type: none"> a. fractures, damage or excessive corrosion b. security of operating valve spindle c. amount of travel d. loose connections or leaks <p>Note: It must be remembered that certain pneumatic components are subject to some degree of leakage.</p> <ol style="list-style-type: none"> e. wear in gate and/or lever locating mechanism f. damping of the lever gate on valves controlling lock actuators. 2. Check the valve unit for: <ol style="list-style-type: none"> a. security of its mounting b. location c. correct functioning. 	<ol style="list-style-type: none"> 1. <ol style="list-style-type: none"> a. Deliberate modification which significantly reduces the original strength, excessive corrosion, damage, fracture or an inadequate repair of the control b. an insecure operating valve spindle c. the control cannot be moved over its full travel d. a loose connection or a leak in the system e. a gate and/or locating mechanism so worn that the lever is not safely retained in the "on" or "off" position f. insufficient or no damping of the lever gate on valves controlling lock actuators. 2. <ol style="list-style-type: none"> a. An insecure valve unit b. the lever located so that it cannot be operated satisfactorily from the normal driving position c. a valve malfunctioning.

3.3 Service Brake Control

Information	Method of Inspection	Reason for Rejection
<p>Vehicles with a smooth brake pedal pad which from manufacture did not incorporate grooves or the fitting of an anti-slip material should not be subject to rejection.</p> <p>The provision of a pedal rubber which is itself an anti-slip material is not regarded as a reason for rejection if the design pattern is worn smooth.</p>	<p>A. All types of braking systems</p> <p>1. Check:</p> <ul style="list-style-type: none"> a. the condition of the brake pedal and brake actuating linkage (e.g., to remote master cylinders) b. the anti-slip face on the pedal pad c. the security of the pedal pad to the pedal and the pedal to operating lever d. the condition of the pedal bearing or pivot e. for chafed rods or levers f. for frayed or knotted cables g. for any corroded or damaged rod, lever or linkage. Wear in eyes of relay levers, clevis joints, stationary pins or pivots h. for abnormal movement of levers, indicating maladjustment or excessive wear. <p style="text-align: right;">Cont'd ↓</p>	<p>1.</p> <ul style="list-style-type: none"> a. The pedal or actuating linkage fractured, excessively corroded or functionally incomplete b. the anti-slip provision on the brake pedal pad is missing, incomplete, loose or worn smooth c. a pedal pad or operating lever not secure to the pedal d. excessive side movement of the pedal at right angles to its normal movement indicating a badly worn pedal bearing or pivot e. a brake rod or lever reduced in thickness by more than 1/3rd f. a brake cable: <ul style="list-style-type: none"> • knotted or, • with wires broken so that the cable is weakened significantly g. serious weakening of any part due to excessive wear, damage or corrosion h. abnormal movement of levers indicating maladjustment or excessive wear. <p style="text-align: right;">Cont'd ↓</p>

3.3 Service Brake Control

Method of Inspection	Reason for Rejection
<p>2. Examine the vehicle structure near actuating linkage and mounting points for excessive corrosion, distortion and fracture.</p> <p>3. On vehicles first used on or after 1 January 1968, check that a brake is applied to all the wheels (this may need to be substantiated during the brake test).</p> <p>4. Depress the pedal and check for fouling on parts of the vehicle.</p> <p>5. Depress the pedal fully and check the position of the pad relative to the floor.</p> <p>6. Check the service brake control for any inappropriate repair or modification.</p>	<p>2. Deliberate modification which significantly reduces the original strength, excessive corrosion, severe distortion, a fracture or an inadequate repair of a load bearing member, its supporting structure or supporting panelling within 30cm of an actuating linkage mounting point, that is, within a 'prescribed area' see Appendix C.</p> <p>3. On vehicles first used on or after 1 January 1968 a brake is not applied to all the wheels.</p> <p>4. The pedal is fouling parts of the vehicle so that free movement of the pedal is obstructed.</p> <p>5. When the pedal is fully depressed, there is not enough reserve pedal movement. Note: This does not apply to power operated braking systems, providing the foot valve is fully open before the pedal is fully depressed.</p> <p>6. A service brake control inappropriately repaired or modified.</p>

3.3 Service Brake Control

Information	Method of Inspection	Reason for Rejection
<p>This Inspection applies to all vehicles where pedal creep has been detected when pressurising the brakes with the engine running.</p>	<p>B. Hydraulic systems (including Servo Assisted)</p> <ol style="list-style-type: none"> 1. Fully depress the pedal twice, first slowly and then rapidly each time to a point where sustained pressure can be held. Check for creep and sponginess. 2. If a vacuum servo is fitted, then with the engine off, totally deplete the stored vacuum by repeatedly applying the service brake. Fully apply the brake and hold at a constant pressure. Note whether the pedal can be felt to travel further when the engine is started. <p>C. Vehicles with high servo boost</p> <ol style="list-style-type: none"> 1. Where possible check the brake fluid level in the reservoir then pump the brake pedal several times and check that the fluid level in the reservoir is unchanged. Note: Under no circumstances must the reservoir cap be removed. 2. With the vacuum depleted ensure the pedal is not spongy or does not creep. 3. With servo assistance fully depress the pedal. 	<ol style="list-style-type: none"> 1. <ol style="list-style-type: none"> a. The pedal tends to creep down while held under pressure b. sponginess indicating air in the hydraulic system. 2. No dip can be felt when the engine is started, indicating vacuum assistance is not working satisfactorily. 1. After several applications of the brake pedal the fluid level in the reservoir has decreased. 2. With the vacuum depleted the pedal is spongy or creeps. 3. With servo assistance the pedal creeps down and touches the floor.

3.3 Service Brake Control

Information	Method of Inspection	Reason for Rejection
<p>Some vehicles with full power hydraulic braking systems will illuminate the low pressure warning light as soon as the ignition is switched on. In these circumstances it is not a Reason for Rejection unless the warning light stays on after the engine has been started.</p>	<p>D. Full power hydraulic braking systems</p> <ol style="list-style-type: none">1. Check that a warning device is fitted.2. Check whether a warning device fitted is audible or visible to the driver.3. With the engine switched off, repeatedly apply the service brake until the warning device operates. Check that at least two further applications of the brakes are available. In case of doubt the availability of two further applications can be established when testing the brakes on a Roller Brake Tester.	<ol style="list-style-type: none">1. No warning device fitted.2.<ol style="list-style-type: none">a. A warning device not visible (or audible) to the driverb. a visual warning device not readily visible to the driver in darkness.3.<ol style="list-style-type: none">a. A warning device not working correctlyb. insufficient reserve pressure to give at least two further applications of the brakes after the warning device has operated.

3.3 Service Brake Control

Information	Method of Inspection	Reason for Rejection
<p>This inspection applies to vehicles registered on or after 1 October 1937.</p> <p>A vehicle that weighs 3050kg or less unladen, with a reservoir coupled direct to the induction manifold, or a reservoir integral in a servo unit, is not necessarily required to be fitted with a warning device.</p> <p>A defective audible warning device is not a Reason for Rejection if fitted in addition to an operational visual device.</p> <p>For vehicles first used on or after 1 April 1983, a defective visual warning device is not a reason for rejection if fitted in addition to an operational audible device.</p> <p style="text-align: right;">Cont'd ↓</p>	<p>E. Air and vacuum systems (including 'over hydraulic')</p> <ol style="list-style-type: none"> 1. Check that a visual warning device or, as an alternative for vehicles first used on or after 1 April 1983, an audible warning device is: <ol style="list-style-type: none"> a. fitted b. working correctly. 2. Check that any visual warning device is: <ol style="list-style-type: none"> a. visible from the driving seat b. illuminated, or otherwise visible from the driver's seat in darkness. 3. For systems fitted with a pressure or vacuum gauge, with the reservoir at a maximum pressure or vacuum, note the reading on the gauge and then fully depress the pedal. Keep the pedal depressed and watch the gauge reading. <p>Note: All vehicles must also be checked for pressure or vacuum leaks during the under-vehicle inspection of the brake system.</p> 4. Check that the operation of any air or vacuum-powered system (e.g. wipers etc.) does not adversely affect the operation of the braking system. <p style="text-align: right;">Cont'd ↓</p>	<ol style="list-style-type: none"> 1. A mandatory warning device: <ol style="list-style-type: none"> a. not fitted b. not working correctly. 2. A visual warning device: <ol style="list-style-type: none"> a. not visible from the driver's seat b. not illuminated, or its function not visible from the driver's seat in darkness. 3. The gauge reading drops whilst the pedal is kept depressed, indicating a leak in the brake system. 4. The repeated operation of any ancillary air or vacuum system completely depletes the stored air or vacuum for the braking system. <p style="text-align: right;">Cont'd ↓</p>

3.3 Service Brake Control

Information	Method of Inspection	Reason for Rejection
<p>If the pressure or vacuum gauge has no warning mark, the following reference values should be used when assessing whether there is still enough pressure or vacuum in the system:</p> <ul style="list-style-type: none">• 45psi (3.1kg/sq cm or 3 bar) for a pressure gauge• 10" to 12" (25 to 30cm) for a vacuum gauge.	<p>5. By applying the service brake repeatedly, gradually empty the braking system, and</p> <p>a. if a gauge is fitted, note that:</p> <ul style="list-style-type: none">• the reading on the gauge falls steadily each time the brake pedal is depressed, and• when the gauge needle has reached the "warning mark", there is still enough pressure or vacuum in the system to allow the brake to be applied at least twice more with pressure or vacuum assistance <p>b. if a warning light or other device is fitted, check that, after the warning has operated there is still enough pressure or vacuum in the system to allow the brake to be applied at least twice more with pressure or vacuum assistance.</p> <p>6. Completely empty the reservoir by repeatedly pressing the service brake pedal. Start the engine and if diesel run it at just below the governed speed or 2000 rpm if petrol. Note the time it takes for the warning device to stop operating.</p>	<p>5.</p> <p>a. Insufficient pressure or vacuum to give assistance to brakes for at least two or more applications after the gauge has reached the warning mark</p> <p>b. insufficient pressure or vacuum to give assistance to brakes for at least two or more applications after the warning light or other device has operated.</p> <p>6. The time between starting the engine and the warning device ceasing to operate or the gauge showing a safe reading indicates that build-up of pressure/vacuum is too slow.</p> <p>For example:</p> <ul style="list-style-type: none">• more than 3 minutes for pressure systems• 1 minute for vacuum systems.

3.4 Anti-Lock Braking and Electronic Stability Control Systems

Information	Method of Inspection	Reason for Rejection
<p>This inspection applies to all systems whether original equipment, 'optional' or after-market.</p> <p>Electronic Stability Control Systems are commonly referred to as ESC, but may also be known as ESP or some other acronym. The dashboard warning lamp for these systems may take various forms and a vehicle should only be failed when the tester is certain that an illuminated lamp indicates an ESC malfunction. This may require reference to the owner's handbook if one is available.</p> <p>The inspection of ESC Systems does not apply to Class 3 vehicles.</p> <p>When testing vehicles that have ABS fitted the road wheels should not be allowed to rotate clear of the standing surface with the ignition on as this can cause the ABS system to indicate a fault which may require specialist equipment to rectify.</p> <p>If an ABS or ESC system has been intentionally rendered inoperative, the whole system must be removed. However, this does not apply to sensor rings or other ABS components which are an integral part of another component e.g. brake disc or drive shaft.</p> <p>Some extended wheelbase vehicles, such as hearses and stretched limousines, may have their ESC system disabled for technical reasons. The Reasons for Rejection in relation to ESC do not therefore apply to these vehicles, even if the MIL is permanently illuminated.</p>	<ol style="list-style-type: none">1. If the vehicle is fitted with an ABS and/or ESC system, check that the relevant warning lamp(s):<ol style="list-style-type: none">a. is fittedb. illuminatesc. does not indicate a fault2. Check the presence and condition of all visible ABS and ESC system components.3. Check the condition of all visible ABS and ESC system wiring.4. Check all ABS and ESC system components for any inappropriate repair or modification.5. Check the condition and operation of the switch (if fitted) to turn the ESC system on and off.	<ol style="list-style-type: none">1. A warning lamp:<ol style="list-style-type: none">a. is missingb. does not illuminatec. indicates a fault2. An ABS or ESC system component obviously missing or excessively damaged.3. ABS or ESC system wiring excessively damaged.4. An ABS or ESC system component inappropriately repaired or modified.5. An ESC system switch insecure or faulty.

3.5 Mechanical Brake Components

Information	Method of Inspection	Reason for Rejection
<p>It is acceptable to fit cable expanders to reduce maladjustment.</p> <p>A visual and physical check must be carried out on all mechanical components that are visible and accessible.</p> <p style="text-align: right;">Cont'd ↓</p>	<ol style="list-style-type: none"> 1. Check the mechanical brake components for: <ol style="list-style-type: none"> a. chafed rods or levers b. frayed or knotted cables c. free rotation of clevis joints between cables and levers (this includes cable linkages between brake pedals and remote mounted servos) d. security of cables, rods and clevis joints e. a corroded or damaged rod, lever or linkage. Wear in eyes of relay levers, clevis joints, stationary pins or pivots f. abnormal movement of levers, indicating maladjustment or excessive wear g. security and excessive wear of brake linings/pads h. contamination of brake discs and drums by leaking brake fluid, oil or grease i. the condition and security of brake drums and discs j. presence and security of brake back plates, wheel cylinders and calipers <p style="text-align: right;">Cont'd ↓</p>	<ol style="list-style-type: none"> 1. <ol style="list-style-type: none"> a. A brake rod or lever reduced in thickness by more than 1/3rd b. a brake cable: <ul style="list-style-type: none"> • knotted or, • with wires broken so that the cable is weakened significantly c. seizure of clevis joint pivots which causes strain or wear to cables to an extent likely to lead to premature failure of the cable d. a cable, rod or clevis joint insecure e. serious weakening of any part due to excessive wear, damage or corrosion f. abnormal movement of levers indicating maladjustment or excessive wear g. a brake lining or pad insecure or less than 1.5 mm thick at any point h. a brake disc or drum contaminated by brake fluid, oil or grease i. a brake disc or drum in such a condition that it is seriously weakened or insecure j. a brake back plate, wheel cylinder or caliper securing device loose, missing or excessively deteriorated <p style="text-align: right;">Cont'd ↓</p>

3.5 Mechanical Brake Components

Information	Method of Inspection	Reason for Rejection
<p>Brake slack adjusters are usually only found on large vehicles with air braking systems.</p>	<ul style="list-style-type: none">k. restriction of free movementl. presence and security of locking devices <p>Note: It is not always possible to determine the presence and effectiveness of certain types of locking devices e.g. locking fluid or 'nyloc' nuts.</p> <ul style="list-style-type: none">m. condition and operation of brake slack adjustersn. any inappropriate repair or modification.	<ul style="list-style-type: none">k. restricted free movement of brake componentsl. a locking device missing or insecurem. a brake slack adjuster obviously defective or incorrectly installedn. a mechanical brake component inappropriately repaired or modified.

3.6 Braking Systems and Additional Braking Devices

Information	Method of Inspection	Reason for Rejection
<p>This inspection applies to all types of braking system.</p> <p>Repairs to the pressure lines of hydraulic brake systems are unacceptable unless suitable connectors are used. Compression joints of a type using separate ferrules are not suitable.</p>	<p>A. All Braking Systems</p> <ol style="list-style-type: none">1. Check for leaks in any part of the braking system with and without the brakes being applied.2. Check all components for security, condition and operation. Note: It is not always possible to determine the presence and effectiveness of certain types of locking devices e.g. locking fluid or 'nyloc' nuts.3. Check all braking system components for any inappropriate repair or modification.	<ol style="list-style-type: none">1. A leak in any part of a braking system.2. A braking system component:<ol style="list-style-type: none">a. insecurely mountedb. excessively weakened by corrosionc. damaged to the extent that its function is impairedd. retaining or locking device missing or insecure.3. A braking system component inappropriately repaired or modified.

3.6 Braking Systems and Additional Braking Devices

Information	Method of Inspection	Reason for Rejection
<p>If the vehicle is fitted with vacuum or power operated brakes the engine must be running during these inspections.</p> <p>A missing brake pipe clip is not necessarily a Reason for Rejection provided the brake pipe remains adequately supported.</p> <p>To correctly assess the condition of corroded metal brake pipes, surface dirt might have to be removed. This might require light scraping with the Corrosion Assessment Tool 'spade end'. Care must be taken not to damage any protective coating.</p> <p>Chafing, corrosion or damage to a rigid brake pipe so that its wall thickness is reduced by 1/3 (e.g. approximately 0.25 mm for typical hydraulic brake pipe) is a reason for rejection.</p> <p>A hose should be rejected for cracking or chafing only if it is severe enough to expose the reinforcement.</p> <p>Certain alloy components may have a white surface deposit which is not to be regarded as 'excessive corrosion'.</p>	<p>B. Brake Pipes and Flexible Hoses</p> <ol style="list-style-type: none"> 1. Check that rigid brake pipes are securely held and not free to vibrate. 2. Check all accessible rigid brake pipes for: <ol style="list-style-type: none"> a. fouling by a moving part b. kinks c. chafing, corrosion and damage. 3. Examine flexible hoses for signs of weakness under pressure with brake fully applied. 4. Examine all flexible hoses for: <ol style="list-style-type: none"> a. room to move as necessary without fouling any part of vehicle b. kinks c. stretching or twisting d. chafing, damage or deterioration e. condition of ferrules f. exposure to excessive heat. 	<p>Reason for Rejection</p> <ol style="list-style-type: none"> 1. A rigid brake pipe inadequately clipped or otherwise supported. 2. A rigid brake pipe: <ol style="list-style-type: none"> a. fouled by moving parts b. kinked c. excessively chafed, corroded or damaged. 3. A flexible hose bulging under pressure. 4. A flexible hose: <ol style="list-style-type: none"> a. has insufficient room to move, resulting in fouling b. kinked c. stretched or twisted d. excessively chafed, damaged or deteriorated e. brake hose ferrule(s) excessively corroded f. exposed to excessive heat.

3.6 Braking Systems and Additional Braking Devices

Method of Inspection	Reason for Rejection
<p>C. Servos and Master Cylinders</p> <ol style="list-style-type: none"> 1. Check servos for: <ol style="list-style-type: none"> a. presence b. condition of vacuum pipe c. leaks. 2. Where an adjustment indicating rod is provided, check if brake adjustment is necessary. 3. Examine the condition of chassis or body structure and panelling around the master cylinder or combined master cylinder / servo mounting. 	<ol style="list-style-type: none"> 1. A servo: <ol style="list-style-type: none"> a. missing when fitted as standard b. vacuum pipe deteriorated, kinked, split, collapsed or excessively chafed c. leaking. 2. Adjustment indicating rod shows brake adjustment is necessary. 3. Deliberate modification which significantly reduces the original strength, excessive corrosion, severe distortion, a fracture or an inadequate repair of a load bearing member or its supporting structure or supporting panelling within 30cm of the master cylinder/servo mounting, that is, within a 'prescribed area', see Appendix C.
<p>D. Reservoirs (Air/Vacuum) (including accumulators, pressure and vacuum vessels)</p> <ol style="list-style-type: none"> 1. Check reservoir mountings and securing straps: <ol style="list-style-type: none"> a. are free from cracks, fractures and excessive corrosion b. do not chafe the reservoir or other fittings. 2. Check that the reservoir capacity is not unduly reduced by deformation. 	<ol style="list-style-type: none"> 1. Reservoir mountings and securing straps: <ol style="list-style-type: none"> a. cracked, fractured or excessively corroded b. chafing reservoir or other fittings. 2. A significant reduction in reservoir capacity as a result of deformation.

3.6 Braking Systems and Additional Braking Devices

Information	Method of Inspection	Reason for Rejection
<p>If more than one pump or compressor drive belt is fitted as standard, only one of the belts needs to be present and/or in a satisfactory condition.</p> <p>Hydraulic brake fluid level checks are confined to transparent reservoirs or where an indicator is fitted. Reservoir caps should not be removed.</p> <p>A brake fluid warning lamp may be a combined lamp for other aspects, such as worn brake pads or parking brake applied.</p> <p>Inspection of the brake fluid warning lamp does not apply to Class 3 vehicles.</p>	<p>E. Valves</p> <ol style="list-style-type: none"> 1. Check for excessive discharge of oil from valves. 2. Check that a load sensing valve is present and connected, if it is a standard item. 3. Check the condition and operation of the load sensing valve where fitted, including any operating linkage. <p>F. Pumps and Compressors</p> <ol style="list-style-type: none"> 1. Check the condition of the pump or compressor drive system. <p>G. Hydraulic Systems</p> <ol style="list-style-type: none"> 1. Check fluid reservoirs for: <ol style="list-style-type: none"> a. presence of cap b. fluid level. 2. Check that the brake fluid warning lamp is not illuminated or defective. 	<ol style="list-style-type: none"> 1. Excessive discharge of oil from a valve. 2. Evidence that a load sensing valve has been removed or disconnected from a vehicle where it is known to have been fitted as standard. 3. A load sensing valve or its operating linkage obviously: <ul style="list-style-type: none"> • seized or inoperative • defective so that its function is impaired, or • incorrectly adjusted. <ol style="list-style-type: none"> 1. A pump or compressor drive system missing or defective. <ol style="list-style-type: none"> 1. A fluid reservoir: <ol style="list-style-type: none"> a. cap missing b. level below the minimum indication when this is shown. 2. A brake fluid warning lamp is illuminated or inoperative.

3.6 Braking Systems and Additional Braking Devices

Information	Method of Inspection	Reason for Rejection
<p>Additional Braking Devices are fitted to some vehicles to provide additional braking (e.g. electric or fluid retarders or exhaust brakes).</p>	<p>H. Air Systems</p> <ol style="list-style-type: none"> 1. Check each brake cylinder/actuator for travel of operating pistons/diaphragms and mechanisms. <p>I. Additional Braking Devices</p> <ol style="list-style-type: none"> 1. Examine the device, its contacts and other components for condition and security. 2. Check for adequate clearance between the device and other components. 3. Check for presence and condition of heat shields if required. 4. Check for signs of overheating of a component or its surroundings. 5. Check for condition, position and security of electrical wiring and switchgear. 6. Check for exhaust gas or oil leaks. 	<ol style="list-style-type: none"> 1. A brake cylinder/actuator: <ol style="list-style-type: none"> a. inoperative b. has excessive travel of the operating mechanism indicating need for adjustment. 1. A device, contacts or component damaged, contaminated or insecure. 2. Inadequate clearance between the device and other components. 3. A heat shield missing or damaged. 4. Overheating of a component or its surroundings. 5. Wiring in poor condition, badly positioned or not secure. 6. Exhaust gas or oil leaking from the device.

3.6 Braking Systems and Additional Braking Devices

Information	Method of Inspection	Reason for Rejection
<p>This inspection applies to Class 5 vehicles with an electronic braking system e.g. a braking system with no mechanical, hydraulic or pneumatic link between the service brake pedal and the brake actuators.</p>	<p>J. Electronic Braking Systems (Class 5 only)</p> <ol style="list-style-type: none">1. On vehicles fitted with an electronic braking system, check that a warning device:<ol style="list-style-type: none">a. is fittedb. is operativec. does not indicate a fault	<ol style="list-style-type: none">1. The warning device:<ol style="list-style-type: none">a. is missingb. inoperativec. indicates a fault

3.7 Brake Performance (Roller Brake Test)

Information	Method of Inspection	
<p>The brake performance test must be carried out on a properly calibrated and maintained slow-speed roller-brake tester designated as acceptable for the statutory tests, except:</p> <ul style="list-style-type: none">vehicles for which a roller brake tester is not appropriate, orat premises without a roller brake tester where approval has been granted for the test to be carried out by other means. <p>Certain vehicles may not be suitable for testing using a roller brake tester. Testers should take account of the vehicle's drive configuration, transmission type and any Vehicle Specific Information before deciding whether a full or partial roller brake test is appropriate.</p> <p>If additional information is available from the vehicle manufacturer, then this should also be taken into account.</p> <p>Unsuitable vehicles should be tested using a properly calibrated and maintained decelerometer or a plate brake tester designated as acceptable for the statutory tests, see Sub-Section 3.7B and C.</p> <p>A roller brake test is also not appropriate for vehicles with damaged, under-inflated or studded tyres.</p> <p>When testing a veteran car or a vehicle with special controls the driver should be allowed to drive during the test if he/she wishes.</p> <p style="text-align: right;">Cont'd ↓</p>	<p>A. Roller Brake Test</p> <p>For vehicles of a type which can be tested on a roller brake tester.</p> <p>Preparation</p> <p>Examine the tyres of the vehicle to ensure that they are not obviously under-inflated.</p> <p>Determine whether the vehicle has a split (dual) braking system.</p> <p>Note: To determine whether the vehicle has a split (dual) braking system, check the number of pipes from a hydraulic master cylinder or air foot valve. Split (dual) systems normally have at least two pipes. Some hydraulic systems have two master cylinders.</p> <p>Position the front wheels of the vehicle in the rollers of the brake tester and then run both sets of rollers together in a forward direction to align the vehicle.</p> <p>Note: Testers can elect to run the brake rollers individually or together when checking maximum effort, depending on the suitability of the RBT.</p> <p>However, if the rollers are run together and the vehicle fails to meet the minimum performance requirement, the test must be repeated running the rollers individually.</p> <p>If both rollers are run together, it will almost certainly be necessary to chock the wheels not under test.</p> <p style="text-align: right;">Cont'd ↓</p>	

3.7 Brake Performance (Roller Brake Test)

Information	Method of Inspection	Reason for Rejection
<p>Vehicles with automatic transmission must never be roller brake tested with the gear selector in the “P” park position.</p> <p>For vehicles with servo assisted or power braking systems, the engine must be idling while the service brake is being tested.</p> <p>Where it is not possible to read the gauges of the roller brake tester while sitting in the driver’s seat, an assistant may be used to apply the brakes during the test.</p> <p>ATL approved test stations use a Computer Controlled RBT. Testers should follow the sequence of instructions displayed on screen and on completion of the test print off the results.</p> <p>Where a vehicle is ejected from the brake rollers, the required brake efforts may not be achieved. In these circumstances, the test should be repeated in manual mode, running rollers individually.</p> <p>For Class 4 vehicles the ATL system will automatically weigh the vehicle and this presented weight will be used for the brake efficiency calculations. For Classes 5 and 7, brake efficiency must be calculated using the vehicle’s DGW.</p> <p>Vehicles of unknown test weight should be tested as normal. However, if the vehicle does not meet the locked wheel criteria explained in the notes following RfRs 9 and 10, carry out a further brake test using a decelerometer to determine the brake efficiencies.</p> <p style="text-align: right;">Cont’d ↓</p>	<p style="text-align: center;">Method of Inspection</p> <p>Testing the front wheels</p> <ol style="list-style-type: none"> 1. Run the rollers and gradually depress the service brake until maximum effort is achieved, or until the wheel locks and slips on the rollers. Record the reading at which the maximum braking effort is achieved and whether “lock-up” occurs. Release the service brake. 2. Start both sets of rollers and note whether a significant brake effort is recorded from any wheel without a brake being applied. Gradually depress the service brake and watch how the braking effort for each wheel increases. From the previous tests you will know the value at which wheel slip occurs. Aim to stop just short of this. However, if wheel slip is caused unintentionally, start the test again. Note the out-of-balance in braking effort between wheels across each steered axle, disregarding any imbalance when the brake effort from each wheel is less than 40kg. Gradually release the service brake and observe how the braking effort at each wheel reduces. Stop the rollers. <p style="text-align: right;">Cont’d ↓</p>	<p style="text-align: center;">Reason for Rejection</p> <ol style="list-style-type: none"> 1. <ol style="list-style-type: none"> a. Little or no braking effort is recorded from the brake on any wheel, indicating clearly that the brake is not functioning correctly b. see Reason for Rejection 9. 2. <ol style="list-style-type: none"> a. significant braking effort recorded on a road wheel, even though the brake is not applied, indicating that a brake is binding b. evidence of severe brake grabbing or judder as the brake is applied c. the braking efforts at the road wheels do not increase at about the same rate when the service brake is applied gradually d. the out-of-balance of the brakes on the steered road wheels is greater than 25% (30% for Class 5 vehicles) at any time whilst brake effort is increased gradually (see Method of Calculating Brakes Out-of-Balance in Section 3.8) e. the braking efforts at the road wheels do not reduce at about the same rate when the service brake is released gradually. <p style="text-align: right;">Cont’d ↓</p>

3.7 Brake Performance (Roller Brake Test)

Information	Method of Inspection	Reason for Rejection
<p>Vehicles designed before 1 January 1905 and constructed before 31 December 1905 do not require a parking brake.</p> <p>For the Method of Calculating Brake Efficiency see Section 3.8.</p> <p>If the required brake efficiency is only just met, but the tester knows that a higher performance figure is normally obtained for the type of vehicle, the vehicle presenter should be advised that the braking system appears to be in need of adjustment or repair.</p> <p>If the vehicle is fitted with an electronic parking brake, refer to VSI or the manufacturer’s operating instructions for the test procedure.</p> <p>Large vehicles fitted with spring brakes, lock actuators or air assisted parking brakes may require an applied brake test in respect of parking brake efficiency as follows:</p> <ul style="list-style-type: none"> • apply the parking brake fully (the service brake may be used to assist in setting the parking brake) and then release any power assistance • start each brake roller in turn and note the maximum effort recorded. <p>This test must only be carried out using an approved Class 5 roller brake tester with the appropriate ‘Applied Brake test’ programme.</p> <p style="text-align: right;">Cont’d ↓</p>	<p>3. If the vehicle has a parking brake (handbrake), which operates on the front wheels, repeat the process outlined in 1 above using this brake and keeping the “hold-on” button or trigger in the disengaged position the whole time.</p> <p>Testing the rear wheels</p> <p>Release the brakes and drive the vehicle forward until the rear wheels are in the rollers. Run them together as for the front wheels to align the vehicle.</p> <p>4. With one set of rollers revolving at a time, (see information column if ATL approved) gradually depress the service brake until maximum effort is achieved or until the wheel locks and slips on the rollers.</p> <p>Record the maximum braking efforts and whether ‘lock-up’ occurs. Release the service brake.</p> <p>5. Start both sets of rollers and note whether a significant brake effort is recorded from any wheel without a brake being applied. Gradually depress the service brake and watch how the braking effort for each wheel increases.</p> <p>From the previous tests you will know the value at which wheel slip occurs. Aim to stop just short of this. However, if wheel slip is caused unintentionally, start the test again.</p> <p>6. Gradually release the service brake and watch how the braking effort at each wheel reduces. Stop the rollers.</p> <p style="text-align: right;">Cont’d ↓</p>	<p>3.</p> <ol style="list-style-type: none"> Little or no braking effort is recorded from the brake on any wheel, indicating clearly that the brake is not functioning correctly see Reason for Rejection 10. <p>4.</p> <ol style="list-style-type: none"> Little or no braking effort is recorded from the brake on any wheel, indicating clearly that the brake is not functioning correctly see Reason for Rejection 9. <p>5.</p> <ol style="list-style-type: none"> A significant effort recorded on a road wheel, even though the brake is not applied indicating that a brake is binding evidence of severe brake grabbing or judder as the brake is applied the braking efforts at the road wheels do not increase at about the same rate when the service brake is applied gradually. <p>6. The braking efforts at the road wheels do not reduce at about the same rate when the service brake is released gradually.</p> <p style="text-align: right;">Cont’d ↓</p>

3.7 Brake Performance (Roller Brake Test)

Information	Method of Inspection	Reason for Rejection
<p>To avoid possible damage when testing transmission parking brakes, the parking brake efficiency requirement must be calculated using the appropriate vehicle weight before the brake is tested.</p> <p>Testing of the brake must cease as soon as the minimum efficiency requirement is reached when progressively applying the brake.</p> <p>When testing service brake performance on unladen Class 7 vehicles premature wheel lock can occur resulting in less than the required brake effort being achieved.</p> <p>This may be due to the action of load sensing or pressure reducing equipment in the service brake system.</p> <p>In such cases, the service brake percentage efficiency is considered satisfactory if:</p> <ul style="list-style-type: none"> (i) more than half the wheels lock, or (ii) both front wheels lock and at least 100kg (220lb) is achieved by each rear wheel, or (iii) for three axle vehicles; both front wheels lock and at least 50kg (110lb) is achieved by each rear wheel. <ul style="list-style-type: none"> (i) If after applying the above criteria the minimum brake efficiency is still not met, then a decelerometer test should be carried out. <p>Note: It must be remembered that a decelerometer test should not be carried out if the vehicle has already failed for 'little or no braking effort is recorded from the brake on any wheel, indicating clearly that the brake is not functioning correctly'.</p> <ul style="list-style-type: none"> (ii) 	<p>7. If the vehicle has a parking brake (handbrake) which operates on the rear wheels, repeat the process as outlined in 3 above using this brake and keeping the "hold-on" button or trigger in the disengaged position the whole time.</p> <p>Testing transmission (prop shaft) parking brakes</p> <p>8. Carry out the following procedure:</p> <ul style="list-style-type: none"> • place the wheels to be tested in the rollers • run both sets of rollers together to align the vehicle • chock the other wheels of the vehicle fore and aft • run both sets of rollers together • keep the parking brake ratchet disengaged for as long as the brake is applied • apply the brake slowly and progressively without causing transmission snatch. <p>9. Record the appropriate results of the service brake test via the VTS Device, which will calculate the results. Where the VTS Device is unserviceable see paragraph 3 of the Introduction.</p> <p>10. Record the appropriate results of the parking brake test via the VTS Device, which will calculate the results. Where the VTS Device is unserviceable see paragraph 3 of the Introduction.</p>	<p>7.</p> <ul style="list-style-type: none"> a. Little or no braking effort is recorded from the brake on any wheel, indicating clearly that the brake is not functioning correctly b. See Reason for Rejection 10. <p>8. See Reason for Rejection 10.</p> <p>9. The calculated service brake efficiency is too low (see Brake Efficiency Table in Section 3.10).</p> <p>Note: If more than half the wheels braked by the service brake lock, the service brake percentage efficiency is considered to be satisfactory.</p> <p>10. The calculated parking brake efficiency is too low (see Brake Efficiency Table in Section 3.10).</p> <p>Note: If more than half the wheels braked by the parking brake lock, the parking brake percentage efficiency is considered to be satisfactory.</p>

3.7 Brake Performance (Decelerometer Test)

Information	Method of Inspection	Reason for Rejection
<p>Decelerometer brake testing must always be carried out on roads which:</p> <ul style="list-style-type: none"> • have a good surface • are suitable for brake tests when dry or wet • have a minimum of traffic <p>A particular public road should not be used for tests so frequently that it could cause complaints from residents.</p> <p>Vehicles with damaged or significantly under inflated tyres should not be decelerometer brake tested.</p> <p>When using a decelerometer to test a transmission parking brake, keep the ratchet disengaged for as long as the brake is applied. Take the efficiency reading without the occurrence of transmission snatch or judder.</p> <p>If the required brake efficiency is only just met, but the tester knows that a higher performance figure is normally obtained for the type of vehicle, the vehicle presenter should be advised that the braking system appears to need adjustment or repair.</p> <p>Additional braking devices, e.g. retarders, should not be operative during the brake test.</p>	<p>B. Decelerometer Test</p> <ol style="list-style-type: none"> 1. If the vehicle is of a type which cannot be tested on a roller brake tester, set up the decelerometer in the vehicle in accordance with the equipment manufacturer's instructions. Drive the vehicle on a level road at a steady speed of approximately 20mph (32kph) and note the brake efficiency recorded when progressively applying only: <ol style="list-style-type: none"> a. the service brake. b. the parking brake. 2. While the vehicle is decelerating under the action of the service brake note if the steering wheel tends to pull or the vehicle tends to swerve. 3. While the vehicle is decelerating under the action of the parking brake note if the vehicle tends to deviate excessively from a straight line. Record the appropriate results of the brake test via the VTS Device. Where the VTS Device is unserviceable see paragraph 3 of the Introduction. 	<ol style="list-style-type: none"> 1. <ol style="list-style-type: none"> a. The service brake efficiency recorded on the decelerometer does not meet the requirements specified in the Brake Efficiency Table in Section 3.10 b. the parking brake efficiency recorded on the decelerometer does not meet the requirements specified in the Brake Efficiency Table in Section 3.10. 2. When the service brake is applied: <ul style="list-style-type: none"> • there is a severe grab or judder, or • there is a severe pull one way on the steering wheel, and/or • the vehicle swerves appreciably. 3. When the parking brake is applied the vehicle deviates excessively from a straight line.

3.7 Brake Performance (Plate Brake Test)

Information	Method of Inspection	
<p>The brake performance test must be carried out on a properly calibrated and maintained plate brake tester designated as acceptable for the statutory test. (Alternatively a slow-speed roller-brake tester can be used - see section 3.7'A').</p> <p>If the required brake efficiency is only just met, but the tester knows that a higher performance figure is normally obtained for the type of vehicle, the vehicle presenter should be advised that the braking system appears to need adjustment or repair.</p> <p>When using a plate tester to test a transmission parking brake, keep the ratchet disengaged for as long as the brake is applied. Take the efficiency reading without the occurrence of transmission snatch or judder.</p> <p style="text-align: right;">Cont'd ↓</p>	<p>C. Plate Brake Test</p> <p>Preparation</p> <p>Determine whether the vehicle has a single or dual (split) braking system.</p> <p>Note: To determine whether the vehicle has a dual (split) braking system, check the number of pipes from the hydraulic master cylinder or air foot valve. Dual (split) systems normally have at least two pipes.</p> <p>Some hydraulic systems have two master cylinders.</p> <p>Class 4 vehicles: Obtain the vehicle test weight.</p> <p>Class 7 vehicles: Establish the vehicle actual presented weight.</p> <p>Brake efficiency on Class 7 vehicles will be calculated using either:</p> <ul style="list-style-type: none">• the actual DGW where the presented weight is 2000kg or over (the DGW is obtained from the manufacturer's plate fitted to the vehicle, or the 'Ministry' plate if one is fitted - see notes 1 and 2 in Section 3.9), or• a nominal DGW figure of 2600kg if the presented weight is less than 2000kg. <p>Enter the appropriate data to conduct the test.</p> <p style="text-align: right;">Cont'd ↓</p>	

3.7 Brake Performance (Plate Brake Test)

Information	Method of Inspection	Reasons for Rejection
<p>If a vehicle fails any aspect of the plate brake test, the check should be repeated to confirm the Reason for Rejection.</p>	<p>Testing the vehicle</p> <ol style="list-style-type: none"> 1. Drive the vehicle forwards at a steady speed of about 4mph up to the plate tester. Just before the wheels are on the plate high friction surfaces, apply a light constant pressure to the brake pedal. Do not stop on the tester. Note the way in which the brake efforts fluctuate. 2. At the same steady speed of 4mph, again drive the vehicle forwards onto the plate brake tester. As soon as the wheels are on the plate high friction braking surfaces, apply the service brake progressively until maximum effort is achieved. Note the way in which the brake efforts increase and the maximum values achieved. Disregard any imbalance when the brake effort from each front wheel is less than 40kg force. 3. Repeat 2 above using the parking brake and note the maximum values achieved. 4. Record the appropriate results of the brake test via the VTS Device, which will calculate the results. Where the VTS Device is unserviceable see paragraph 3 of the Introduction. <p style="text-align: right;">Cont'd ↓</p>	<ol style="list-style-type: none"> 1. Excessive fluctuation of brake effort with a constant brake pedal effort indicating brake judder. 2. <ol style="list-style-type: none"> a. A significant brake effort recorded on a road wheel, when the brake is not applied, indicating that a brake is binding b. the braking efforts at both road wheels on an axle do not increase at about the same rate when the service brake is applied c. the out-of-balance of the brakes on the steered road wheels is greater than 25% at any time (30% for Class 5) 3. Little or no effort is recorded from the parking brake on any wheel, indicating clearly that the brake is not functioning correctly. 4. <ol style="list-style-type: none"> a. The service brake efficiency is too low (see Brake Efficiency Table requirements in Sections 3.10) b. the parking brake efficiency is too low (see Brake Efficiency Table requirements in Sections 3.10). <p style="text-align: right;">Cont'd ↓</p>

3.7 Brake Performance (Gradient Test)

Information	Method of Inspection	Reasons for Rejection
<p>This test may be conducted as an alternative to a decelerometer test on certain large vehicles with a dual circuit braking system (min. 16% efficiency required) such as Motor Caravans fitted with a prop shaft brake not suitable to be tested on a roller brake tester.</p> <p>Care should be taken to avoid any risk of 'grounding' the vehicle when reversing onto and driving off the test slope.</p>	<p>D. Parking Brake Gradient Test</p> <ol style="list-style-type: none">Reverse the vehicle onto a 16% gradient, apply the parking brake and release power assistance. <p>Note: When the parking brake is being tested by the gradient test, the service brake (foot-brake) may be used to assist in setting the parking brake.</p> <p>Record the appropriate results of the brake test via the VTS Device. Where the VTS Device is unserviceable see paragraph 3 of the Introduction.</p>	<ol style="list-style-type: none">When fully applied, the parking brake is incapable of holding the vehicle on a 16% gradient.

3.8 Method of Calculating Brake Performance (Class 3, 4 & 7)

1. Brake Efficiency (Classes 3, 4 & 7)

The brake efficiency will be calculated by the VTS Device using the following methods (having taken into account wheel lock where appropriate).

Total up the braking effort recorded from all the wheels of the vehicle when the service brake is applied.

Total up the braking effort recorded from the appropriate wheels when the parking brake is applied.

Calculate the service brake and parking brake percentage efficiencies by following the procedures detailed below according to the Class of vehicle tested.

Class 3 and 4 Vehicles

Determine the brake testing weight for the vehicle, e.g. from the VTS Device. The weight includes an element of 140kg for the driver, fuel, tools, etc.

Calculate the service brake percentage efficiency by dividing the total brake effort achieved when the service brake is applied by the vehicle weight and then multiplying the result by 100.

$$\text{i.e. } \frac{\text{Total brake effort}}{\text{Vehicle Weight}} \times 100 = \% \text{ Efficiency}$$

Calculate the parking brake percentage efficiency by dividing the total brake effort achieved when the parking brake is applied by the vehicle weight and then multiplying the result by 100, as above.

Class 7 Vehicles

Obtain the vehicle DGW from the manufacturer's plate fitted to the vehicle (see Section 3.9) or from the VTS Device. If a 'Department for Transport plate' (commonly called 'Ministry' plate) is fitted to the vehicle the DGW should be obtained from here.

Calculate the service brake percentage efficiency by dividing the total brake effort achieved when the service brake is applied by the vehicle DGW and then multiplying the result by 100.

$$\text{i.e. } \frac{\text{Total brake effort}}{\text{DGW}} \times 100 = \% \text{ Efficiency}$$

Calculate the parking brake percentage efficiency by dividing the total brake effort achieved when the parking brake is applied by the vehicle DGW and then multiplying the result by 100, as above.

Note: Plate Brake Test Only

Vehicles with a presented weight of 2000kg or more must be tested to the above criteria. On vehicles with a presented weight of less than 2000kg, the brake efficiency must be calculated using a nominal DGW figure of 2600kg.

$$\text{i.e. } \frac{\text{Total brake effort}}{2600} \times 100 = \% \text{ Efficiency}$$

Alternatively, if ATL approved the computer controlled brake tester will automatically calculate the efficiency and any out of balance.

2. Brake Out-of-Balance

The out of balance of the braking effort on the front steered wheels when the service brake is applied is obtained by comparing the brake efforts at each front wheel when they are tested simultaneously (see sub-sections 3.7.A & C). Carry out the following calculation to determine the percentage imbalance:

$$\frac{(\text{Higher brake effort} - \text{Lower brake effort})}{\text{Higher brake effort}} \times 100 = \% \text{ imbalance}$$

3.8 Method of Calculating Brake Performance (Class 5 only)

1. Brake Efficiency (Class 5)

The brake efficiency will be calculated by the VTS Device using the following methods (having taken into account wheel lock where appropriate).

Total up the braking effort recorded from all the wheels of the vehicle when the service brake is applied.

Total up the braking effort recorded from the appropriate wheels when the parking brake is applied.

The service brake and parking brake percentage efficiencies may be calculated by using the procedures detailed below.

Service Brake Efficiency

Calculate the service brake percentage efficiency by dividing the total brake effort achieved when the service brake is applied by the lesser of the vehicle's DGW or MAM and then multiplying the result by 100.

$$\text{i.e. } \frac{\text{Total service brake effort}}{\text{DGW/MAM}} \times 100 = \% \text{ Efficiency}$$

Parking Brake Efficiency

Calculate the parking brake percentage efficiency by dividing the total brake effort achieved when the parking brake is applied by the lesser of the vehicle's DGW or MAM and then multiplying by 100.

$$\text{i.e. } \frac{\text{Total parking brake effort}}{\text{DGW/MAM}} \times 100 = \% \text{ Efficiency}$$

The DGW/MAM is normally shown on the manufacturers' plate. Where only the unladen weight is shown on the vehicle, calculate the DGW/MAM as follows:

$$[\text{Number of passenger seats (excluding the driver's seat)} \times 63.5\text{kg (or 140lbs)}] + \text{unladen weight}$$

2. Brake Out-of-Balance

The out of balance of the braking effort on the front steered wheels when the service brake is applied is obtained by comparing the brake efforts at each front wheel when they are tested simultaneously (see sub-section 3.7.A2). Carry out the following calculation to determine the percentage imbalance:

$$\frac{(\text{Higher brake effort} - \text{Lower brake effort})}{\text{Higher brake effort}} \times 100 = \% \text{ Imbalance}$$

:

3.10 Brake Efficiency Table (Vehicles with 4 or more wheels)

VEHICLES WITH 4 OR MORE WHEELS (Excluding quadricycles – see Section 9.3)	MINIMUM BRAKE EFFICIENCIES REQUIRED		
	SERVICE BRAKE	PARKING BRAKE	
		Vehicles with a single line service brake system	Vehicles with a split (dual) service brake system
Passenger vehicles with 4 or more wheels, with not more than 8 passenger seats in addition to the driver's seat, having a service brake (foot-brake) operating on at least 4 wheels and a parking (handbrake) operating on at least 2 wheels.	50%	25%	16%
Goods vehicles in Classes 4 or 7	50%	25%	16%
Passenger vehicles with 4 or more wheels, with more than 8 passenger seats in addition to the driver's seat, having a service brake (foot-brake) operating on at least 4 wheels and a parking (handbrake) operating on at least 2 wheels which were first used: On or after 1 January 1968 Before 1 January 1968	50% 45%	25% 20%	16% Not specified (see Note 1)
Vehicles first used before 1 January 1968 which do NOT have one means of control operating on at least 4 wheels and which have one brake system with two means of control or two brake systems with separate means of control.	30% from first means of control	25% from second means of control	
Vehicles first used before 1 January 1915.	One efficient braking system required.		

Note 1: The parking brake on these vehicles must be capable of preventing at least two wheels from rotating when the vehicle is stationary. There is no specified efficiency requirement.

3.10 Brake Efficiency Table (Vehicles with 3 wheels)

VEHICLES WITH 3 WHEELS (CLASSES 3 & 4)	MINIMUM BRAKE EFFICIENCIES REQUIRED		
	SERVICE BRAKE	PARKING BRAKE	
		Vehicles with a single line service brake system	Vehicles with a split (dual) service brake system
Vehicles with 3 wheels with a service brake operating on ALL wheels and a parking brake operating on at least one wheel which were first used:			
i) before 1 January 1968	40%	25%	16%
ii) on or after 1 January 1968	50%	25%	16%
Vehicles first used before 1 January 1968 which do NOT have one means of control operating on at least 4 wheels (or 3 for three wheeled vehicle) and which have one brake system with two means of control or two brake systems with separate means of control.	30% from first means of control	25% from second means of control	

Note: 16% parking brake efficiency equates to a vehicle holding on a gradient of 1 in 6.25

Tyres and Road Wheels

Section Contents

Sub-Section	Subject
-------------	---------

4.1	Tyres
------------	--------------

A. Type of Structure

B. Load Index and Speed Rating
(Applicable to Class 5 & 7 only)

C. Speed Rating – Restricted Speed Vehicles
(Applicable to Class 5 only)

D. Condition of Tyres

E. Tread - Pattern, Breadth and Depth

4.2	Road Wheels
------------	--------------------

A. Applicable to all Vehicles

B. Additional Checks
(Applicable to Class 5, 7 and large Class 4 only)

4.1 Tyres (Structure)

Information	Method of Inspection	Reason for Rejection
<p>This inspection applies to tyres fitted to the road wheels only. The vehicle presenter should be informed when it is noticed that there is a defective tyre on a spare wheel.</p> <p>To identify the size and type of tyres, it might be necessary to rotate the wheels or move the vehicle. Only one sidewall of a tyre needs to be marked.</p> <p>The aspect ratio of a tyre is included in the size marking e.g. a 215/55R15 has an aspect ratio of 55%.</p> <p>“Standard” car tyres have a nominal aspect ratio of 82% (unless marked otherwise) and these are almost identical in size to tyres with an aspect ratio of 80% and can be safely mixed in any configuration on a vehicle. Therefore, in these circumstances Reason for Rejection 1 does not apply.</p> <p>Some tyres may be marked with two sizes. For example, a 185/75R14 tyre may be dual marked 185R14.</p> <p>Where a tyre is found to be dual marked by the manufacturer on the side-wall, either markings can be accepted.</p> <p>Any tyre structure mix between different axles is acceptable for vehicles that have either:</p> <ul style="list-style-type: none">• 2 axles and ‘twin’ wheels on the rear axle, or• 3 axles, one steering and one driving. <p>However, this does not apply to vehicles with tyres having a road contact area of 300mm or wider.</p>	<p>A. Type of Structure</p> <ol style="list-style-type: none">1. Check the nominal size and aspect ratio. Note: It cannot be assumed that there is a difference in the nominal sizes of tyres because either twin wheel is not in contact with the ground. Note: A Class 3 or 4 vehicle tyre which appears to be of inadequate size, ply or speed rating for the vehicle or its use is not a reason for rejection. However, the vehicle presenter should be informed.2. Check the type of structure, i.e. radial, cross-ply or bias-belted. Note: Steel and fabric radial-ply tyres are to be regarded as the same structure type.	<ol style="list-style-type: none">1.<ol style="list-style-type: none">a. One tyre is of a different nominal size or aspect ratio to any other on the same axleb. a ‘temporary use’ or ‘space-saver’ wheel and tyre fitted as a road wheel.2.<ol style="list-style-type: none">a. One tyre is of a different type of structure from another tyre on the same axleb. a 3 or 4-wheeled vehicle fitted with single wheels, and<ol style="list-style-type: none">(i) a cross-ply tyre or bias-belted tyre fitted on the rear axle and radial-ply tyre is fitted on the front axle, or(ii) a cross-ply tyre fitted on the rear axle and a bias-belted tyre fitted on the front axlec. a tyre of a different type of structure is fitted to a steerable axle from that fitted to another steerable axled. In the case of non-steerable axles a tyre fitted to a driven axle is of a different type of structure from that fitted to another driven axle.

4.1 Load Index and Speed Rating (Class 5 & 7 Only)

Information	Method of Inspection	Reason for Rejection
<p>The permitted maximum laden weight of an axle is that shown on the manufacturer's plate (See Section 3.9).</p> <p>Some goods vehicles first used before 1968 and some Class 5 vehicles before 1982 may not be fitted with a manufacturer's plate displaying axle weights. The load capacity of tyres on such vehicles must therefore be assumed suitable, unless there is indisputable evidence to the contrary.</p> <p>If a vehicle is displaying a 'Ministry' plate showing lower axle weights not to be exceeded in Great Britain, these must be used instead of those shown on the manufacturer's plate.</p> <p>A tyre not marked with a load index or ply rating is assumed to have the lowest 'load capacity' of its size.</p>	<p>B. Load Index and Speed Rating (Applicable to Class 5 & 7 only)</p> <ol style="list-style-type: none"> 1. <ol style="list-style-type: none"> a. Check for a load index (or ply rating and tyre size) marked on at least one sidewall of each tyre. (See tables in Appendix D for the identification of tyre load index, ply rating and tyre size) b. check the load index is adequate for the maximum laden weight of the axle. 2. Check for a speed rating letter marked on the sidewall of each tyre. 	<ol style="list-style-type: none"> 1. <ol style="list-style-type: none"> a. A tyre not marked with its size on at least one sidewall. (See tables at the end of this section) b. a tyre that has a load index (or ply rating and tyre size) that is inadequate for the permitted maximum laden weight of the axle to which it is fitted. (See tables at the end of this section for the determination of tyre load capacity). 2. A tyre marked with one of the following speed rating letters: A, B, C, D, E, F, G, J or K. <p>Note: Some tyres are not marked with a 'speed rating' and the absence of such a mark is not a Reason for Rejection.</p>

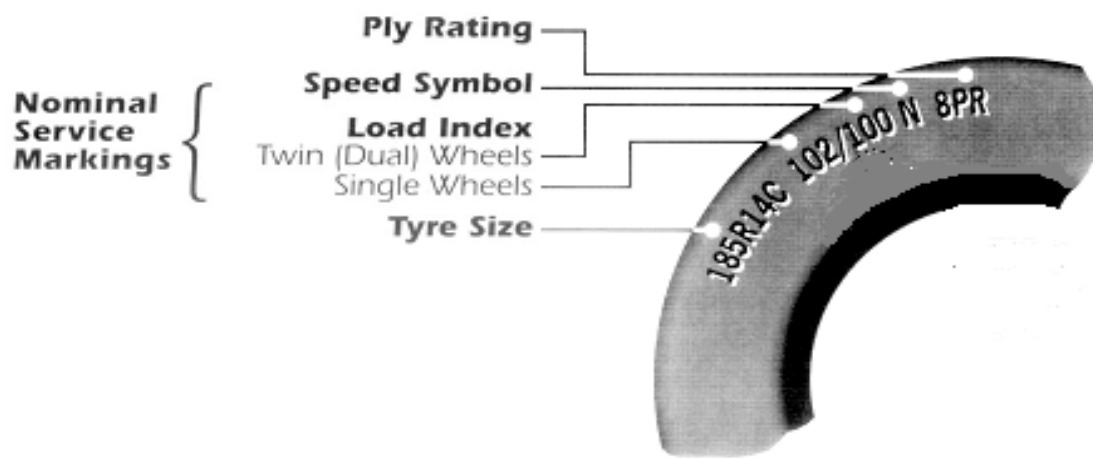

4.1 Tyres (Restricted Speed Vehicles – Class 5 Only)

Information

A 'Restricted Speed Vehicle' is a vehicle displaying at its rear a '50' plate as shown below (at least 150mm wide and 120mm high).

A vehicle displaying this plate is required to have tyres suitable for speeds up to 50mph, i.e. 'F' speed rating or greater.

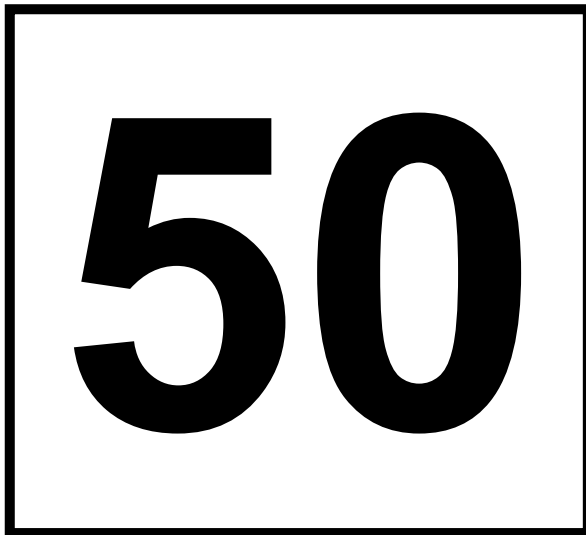

Method of Inspection

C. Speed Rating - Restricted Speed Vehicles (Applicable to Class 5 only)

1. Check for a Speed Rating letter marked on the sidewall of each tyre.

Reason for Rejection

1. A tyre that is fitted to a 'Restricted Speed Vehicle' marked with one of the following Speed Rating letters - A, B, C, D or E.

Cont'd ↓

Cont'd ↓

4.1 Tyres (Additional Information for Class 5 Only)

Information

Other Suitable Speed Ratings (Class 5 only)

Unless the vehicle is a 'Restricted Speed Vehicle' the tyres are required to be suitable for use up to the maximum prescribed speed limit of 70mph, ie 'L' speed rating.

Tyres of the lower speed ratings of 'J' or 'K' however are acceptable for use at 70mph although the increase from the nominated speed rating imposes a reduction in the tyres' carrying capacity.

Note: This allowance is only applicable to the nominal service markings (Load Index/Speed Symbol).

This allows a tyre displaying a '**J' speed rating** (suitable for a maximum of 62mph) to be used at the 'L' speed (suitable for a maximum of 70mph) at the penalty of **reducing the tyres capacity by 7%**.

In the case of a tyre displaying a '**K' speed rating** (suitable for a maximum of 68mph) a **reduction in capacity of 3%** is imposed to allow use up to the 'L' speed.

e.g. 146/143K= 6000kg single/10900kg dual – at a maximum speed of 68mph

Less 3% = 5820kg single/10580kg dual – at a maximum speed of 70mph

This would allow a tyre displaying the speed rating 'K' to be used on a vehicle to which a maximum prescribed speed limit of 70mph applies, subject to it being suitable at the reduced capacity of 5820kg in single and 10580kg in dual formation, for the maximum permitted axle weight of the axle to which it is fitted (the GB maximum permitted weight as shown on the manufacturer's plate).

If during an annual test a tyre of 'J' or 'K' speed rating is fitted to a vehicle subject to a maximum prescribed speed of 70mph and found to be below the weight capacity required, this is a Reason for Rejection.

4.1 Tyres (Condition)

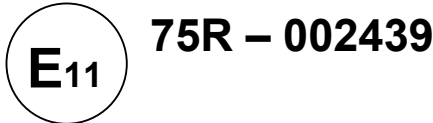
Information	Method of Inspection	Reason for Rejection
<p>Any areas of the tyres that cannot be readily seen with the vehicle on hard standing should be checked by rotating the wheel whilst the axle is jacked up during the under vehicle inspection, or by moving the vehicle to expose the areas that could not previously be seen.</p> <p>Recut tyres are permitted on:</p> <ul style="list-style-type: none"> a goods vehicle at least 2540kg unladen weight having at least 16 inch (405mm) diameter wheels a vehicle with at least 8 passenger seats, excluding the driver's seat, and over 2540kg unladen weight a vehicle over 3050kg unladen weight. <p>Tyres with NHS, Not for Highway Use or similar markings should only be deemed acceptable if they display an 'E' marking and a number contained within a circle. Adjacent to this circle, the sidewall must also be marked with a six digit number, which may be preceded by 75R or similar marking (see example below).</p> <div style="text-align: center;">  </div> <p>Direction of rotation may be indicated by an arrow and/or words, but an arrow by itself should not be taken to indicate direction of rotation.</p> <p style="text-align: right;">Cont'd ↓</p>	<p>D. Condition of Tyres</p> <ol style="list-style-type: none"> Examine each tyre for: <ol style="list-style-type: none"> Cuts <p>Note: It is permissible to check for exposed ply or cord by using a blunt instrument to open a cut, taking care not to cause further damage.</p> lumps, bulges, tears, exposure of the ply or cord, or tread separation <p>Note: On radial ply tyres, care should be taken to distinguish between normal undulations in the carcass, resulting from manufacturing, and lumps or bulges caused by structural deterioration.</p> recut tread incorrect seating in the wheel rim valve condition and alignment correct fitting. <p style="text-align: right;">Cont'd ↓</p>	<ol style="list-style-type: none"> <ol style="list-style-type: none"> A tyre has a cut the length of which is in excess of 25 mm or 10% of section width, whichever is greater, deep enough to reach the ply or cords a tyre has: <ul style="list-style-type: none"> a lump, bulge or tear caused by separation or partial failure of its structure. This includes any lifting of the tread rubber any of its ply or cord exposed a recut tyre fitted to a vehicle not permitted to be so equipped a tyre incorrectly seated on the wheel rim a seriously damaged or misaligned valve stem which could cause sudden deflation of the tyre a tyre not fitted in compliance with the manufacturers sidewall instruction, e.g. <ul style="list-style-type: none"> a tyre marked 'NHS', 'Not for Highway use' or similar an asymmetric with a sidewall marked 'outer' fitted with the marking to the inner side of the wheel. <p style="text-align: right;">Cont'd ↓</p>

4.1 Tyres (Condition)

Information	Method of Inspection	Reason for Rejection
<p>Under-inflation of a tyre is not in itself a reason for rejection. However:</p> <ul style="list-style-type: none">• a brake test might be inadvisable, because of possible damage, or• a headlight test might be affected, if the under-inflation is affecting alignment. <p>The inspection of the tyre pressure monitoring system (TPMS) only applies to passenger vehicles with:</p> <ul style="list-style-type: none">• four or more wheels, and• not more than 8 passenger seats excluding the driver's seat, and• first used on or after 1 January 2012 <p>The check does not apply to quadricycles.</p> <p>The TPMS warning lamp (as below) will generally illuminate and go off again when the ignition is switched on. If one or more tyre pressures are low, the lamp will remain illuminated.</p> <p>In the event of a system malfunction, the lamp will flash a number of times and then remain on.</p> <p>Vehicles must only be rejected if it is clear that the lamp indicates a system malfunction.</p> 	<ol style="list-style-type: none">2. Check tyres for fouling a part of the vehicle. Note: This does not apply to vehicles designed to permit tyre contact with the chassis or frame e.g. steering lock stop function.3. Check tyres on twin wheels for wall contact.4. On vehicles fitted with a tyre pressure monitoring system, check that:<ul style="list-style-type: none">• the system is not obviously inoperative• the warning lamp does not indicate a system malfunction.	<ol style="list-style-type: none">2. A tyre fouling a part of the vehicle. Note: A vehicle should only be rejected if the tyre is actually fouling a part of the vehicle. Evidence of fouling e.g. due to tyre flexing or suspension movement is not a Reason for Rejection.3. Tyres on twin wheels making wall contact due to under-inflation or incorrect fitment. Note: Some tyres, e.g. radial ply tyres, with flexible side walls may touch under load. Wall contact in these circumstances is not a reason for rejection.4. A tyre pressure monitoring system:<ul style="list-style-type: none">• obviously inoperative• warning lamp indicates a system malfunction.

4.1 Tyres (Tread Pattern, Breadth and Depth)

Information

A tread pattern is the combination of plain surfaces and grooves extending across the breadth of the tread and round the entire circumference.

The tread pattern excludes any tie-bars, tread wear indicators, or features designed to wear out substantially before the remainder of the pattern, and other minor features.

Grooves that had not been cut as deep as those containing the wear indicators when new are not to be considered as part of the tread pattern.

The breadth of tread is the part of the tyre which can contact the road under normal conditions of use measured at 90 degrees to the peripheral line of the tread.

A 1.6mm minimum tread depth applies to vehicles first used after 2 January 1933 that are either:

- a. a passenger carrying vehicle (car, motor caravan etc) with not more than 8 passenger seats, excluding the driver's, or
- b. a goods vehicle or dual purpose vehicle not exceeding 3500kg maximum gross weight.

Tricycle and quadricycle requirements are detailed at Section 9.4.

Cont'd ↓

Method of Inspection

E. Tread - Pattern, Breadth and Depth 1.6mm tread depth

1. Check the tread pattern over the complete circumference of the tyre. Check also that the tread depth meets the requirements using, as necessary, a depth gauge accepted for MOT testing.

Reason for Rejection

1. The grooves of the tread pattern are not at least 1.6mm throughout a continuous band comprising:

- the central three-quarters of the breadth of tread, and
- round the entire outer circumference of the tyre.

Note: Each side of the central band of the tyre can be devoid of tread (i.e. 'bald') and still meet the pass standard. See diagram below.

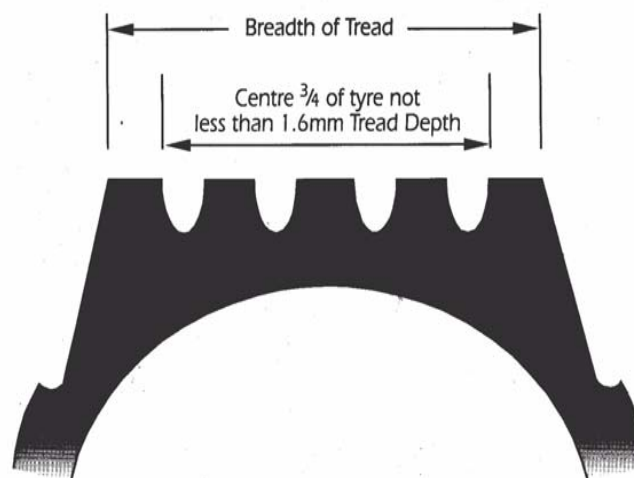

Cont'd ↓

Cont'd ↓

4.1 Tyres (Tread Pattern, Breadth and Depth)

Information	Method of Inspection	Reason for Rejection
<p>A 1.0mm minimum tread depth applies to:</p> <ul style="list-style-type: none">• a passenger-carrying vehicle with more than 8 passenger seats excluding the driver's seat• a vehicle first used before 3 January 1933. <p>Tricycle and quadricycle requirements are detailed at Section 9.4.</p>	<p>1.0 mm tread depth</p> <ol style="list-style-type: none">2. Check the tread pattern over the complete circumference of the tyre. Check also that the tread depth meets the requirements using, as necessary, a depth gauge accepted for MOT testing.	<ol style="list-style-type: none">2. A tyre with a tread pattern:<ol style="list-style-type: none">a. not visible over the whole tread area, andb. the depth of which is not at least 1mm throughout a single band:<ul style="list-style-type: none">• round the entire outer circumference of the tyre• of at least three-quarters of the breadth of tread. <p>Note: The 1.0mm tread depth requirement applies to the whole tread width if the original tread pattern did not extend beyond three-quarters of the tyre width when new.</p>

4.2 Road Wheels

Information	Method of Inspection	Reason for Rejection
<p>This inspection applies to the road wheels fitted to the vehicle at the time of the inspection only.</p> <p>The vehicle presenter should be informed if a defect is noticed on a spare wheel.</p> <p>Removal of wheel hub caps etc. is not permitted.</p>	<p>A. Applicable to all vehicles</p> <ol style="list-style-type: none">1. Check all road wheels for:<ol style="list-style-type: none">a. cracks, damage and distortion, particularly the rimb. presence and condition of spokes c. securityd. stud hole(s) visibly badly worn e. a wheel stud, bolt or nut loose or missing.	<ol style="list-style-type: none">1.<ol style="list-style-type: none">a. A wheel badly damaged, distorted or cracked, or with a badly distorted bead rimb. a wheel which has a spoke(s) missing, cracked or excessively:<ul style="list-style-type: none">• loose• bent, or• corrodedc. a wheel insecured. excessive elongation of a stud hole(s) in a wheele. a wheel stud, bolt or nut loose or missing.

4.2 Road Wheels (Additional Checks)

Information	Method of Inspection	Reason for Rejection
<p>These additional inspection items apply to Class 5, 7 and large Class 4 vehicles only.</p> <p>It may not be possible to inspect every part of the road wheels from ground level, particularly within twin wheels or where the wheels are partly hidden by other parts of the vehicle or body.</p> <p>In such cases, the examination will need to be completed from beneath the vehicle during the underside inspection and the vehicle moved if necessary to expose the areas that could not previously be seen.</p>	<p>B. Additional checks</p> <ol style="list-style-type: none"> 1. Check all road wheels for any: <ol style="list-style-type: none"> a. fracture b. fracture of a tyre retaining ring c. weld breaking away d. butting at the ends of a tyre retaining or locking ring. 2. Check for compatibility of wheel and fixings. 3. Check half shaft bolts, nuts and studs for security. 4. Check hubs for damage or cracks. 5. For spigot-mounted wheels, check for wear at spigot mounting between wheel and hub. 	<ol style="list-style-type: none"> 1. <ol style="list-style-type: none"> a. A fracture on a wheel except at the bridge over the valve b. a tyre retaining ring fractured c. a weld breaking away d. a tyre retaining ring butting so that the ring is visibly displaced from its seating <p>Note: With detachable spring retaining rings on wheel rims of semi-drop centre type (identified by the ends of the ring shaped to interlock), abutting ends are permissible if retainer is adequately and safely located in the wheel rim.</p> 2. A wheel and its fixings not compatible. 3. A half shaft bolt, nut or stud loose or missing. 4. A hub cracked or badly damaged. 5. Excessive wear between wheel and hub at spigot mounting.

Seat Belts and Supplementary Restraint Systems (SRS)

Section Contents

Sub-Section	Subject
-------------	---------

5.1	Seat Belt Requirements
------------	-------------------------------

- Fitment

- General Information

- Three-Wheeled Vehicles

- Passenger Vehicles, Motor Caravans and Ambulances with up to 8 Passenger Seats

- Minibuses, Motor Caravans and Ambulances with 9-12 Passenger Seats

- Minibuses, Motor Caravans and Ambulances with 13-16 Passenger Seats

- Coaches and Other Buses

- Goods Vehicles and Living Vans

- Seat Belt Types

5.2	Seat Belt Condition
------------	----------------------------

5.3	Seat Belt Installation Requirements (Class 4A & 5A approved VTS only)
------------	--

- Seat belt Installation Check

- Vehicles Exempt from Seat belt Installation Checks

- Seat belt Installation Guidance Notes

5.4	Supplementary Restraint Systems (SRS)
------------	--

5.1 Seat Belt Requirements: Fitment

Information	Method of Inspection	Reason for Rejection
<p>This inspection applies to all statutory seat belts. For additional information see pages 2-10 of this section.</p>	<p>Statutory fitment</p> <ol style="list-style-type: none">1. Check that each seat that requires a seat belt is fitted with one of the appropriate type.	<ol style="list-style-type: none">1. A statutory seat belt:<ul style="list-style-type: none">• missing• of the wrong type.

5.1 Seat Belt Requirements: General Information

1. Seats requiring belts

Seatbelt requirements depend on vehicle age, type and number of seats. To determine the requirements refer to the flow charts on pages 3 to 8 and then the relevant table on pages 9 to 10 in conjunction with the following notes. **Unless stated**, seats are not required to be fitted with seat belts.

2. Passenger seats

Passenger seats are those designated for normal use when the vehicle is travelling on the road. Seating arrangements only intended for use when the vehicle is stationary (e.g. settee etc in the living area of a motor caravan) are not required to have seat belts.

3. Side facing seats

Side facing seats are not required to be fitted with seat belts.

4. Occasional seats

Occasional seats that fold down when not in use are not required to be fitted with seat belts. Care must be taken in assessing whether seats are, by manufacture, **intended** for everyday use with the ability to be folded for extra luggage space or **intended** for occasional use. Seats for everyday use should not be considered as “occasional” seats.

5. Goods vehicle conversion

A goods vehicle which has been converted to a passenger vehicle specification (i.e. fitted with rear seats and side windows etc.) must comply with the relevant “passenger vehicle” requirements.

6. Seats in goods vehicles

Seats fitted to the rear of the driver’s compartment in a goods vehicle are not required to be fitted with seat belts unless the seat is the specified front passenger seat (see note 7).

7. Specified front passenger seat

The “specified front passenger seat” requiring a seat belt is the seat which is:

- foremost in the vehicle and
- furthest from the drivers seat

Unless there is a fixed partition separating the passenger seat from a space in front of it which is alongside the driver’s seat, e.g. certain types of taxis, buses etc.

8. 3 Point belt

“3 point belt” means a seat belt which:

- restrains the upper and lower parts of the torso
- includes a lap belt
- is anchored at not less than three points
- is designed for use by an adult.

9. Adult harness belts

Adult harness belts comprising a lap belt and shoulder straps are an acceptable alternative to any of the seat belt types listed.

10. Vehicle definitions

An ‘ambulance’ is a motor vehicle which is specially designed and constructed (and not merely adapted) for carrying as equipment permanently fixed to the vehicle, equipment used for medical, dental, or other health purposes and is used primarily for the carriage of persons suffering from illness, injury or disability.

A ‘motor caravan’ is “a motor vehicle (not being a living van) which is constructed or adapted for the carriage of passengers and their effects and which contains, as permanently installed equipment, the facilities which are reasonably necessary for enabling the vehicle to provide mobile living accommodation for its users”. Motor caravans are not classed as goods vehicles for MOT test purposes and are therefore in Class 4 or 5 depending on their seating capacity but regardless of their size or weight.

A ‘living van’ is “a vehicle, whether mechanically propelled or not, which is used for living accommodation by one or more persons and which is also used for the carriage of goods or burden which are not needed by such one or more persons for the purpose of their residence in the vehicle”. Living vans are classed as goods vehicles and, depending on their weight, are therefore in either Class 4 or 7 within the MOT test scheme or are subject to HGV plating and testing.

A ‘coach’ is a motor vehicle which is constructed or adapted to carry more than 16 seated passengers, with a DGW of more than 7,500kg and a maximum speed in excess of 60mph.

5.1 Seat Belt Requirements: Fitment

Three-Wheeled Vehicles First Used Before 17 June 1999

Note: For vehicles first used on or after this date see Section 9.5.

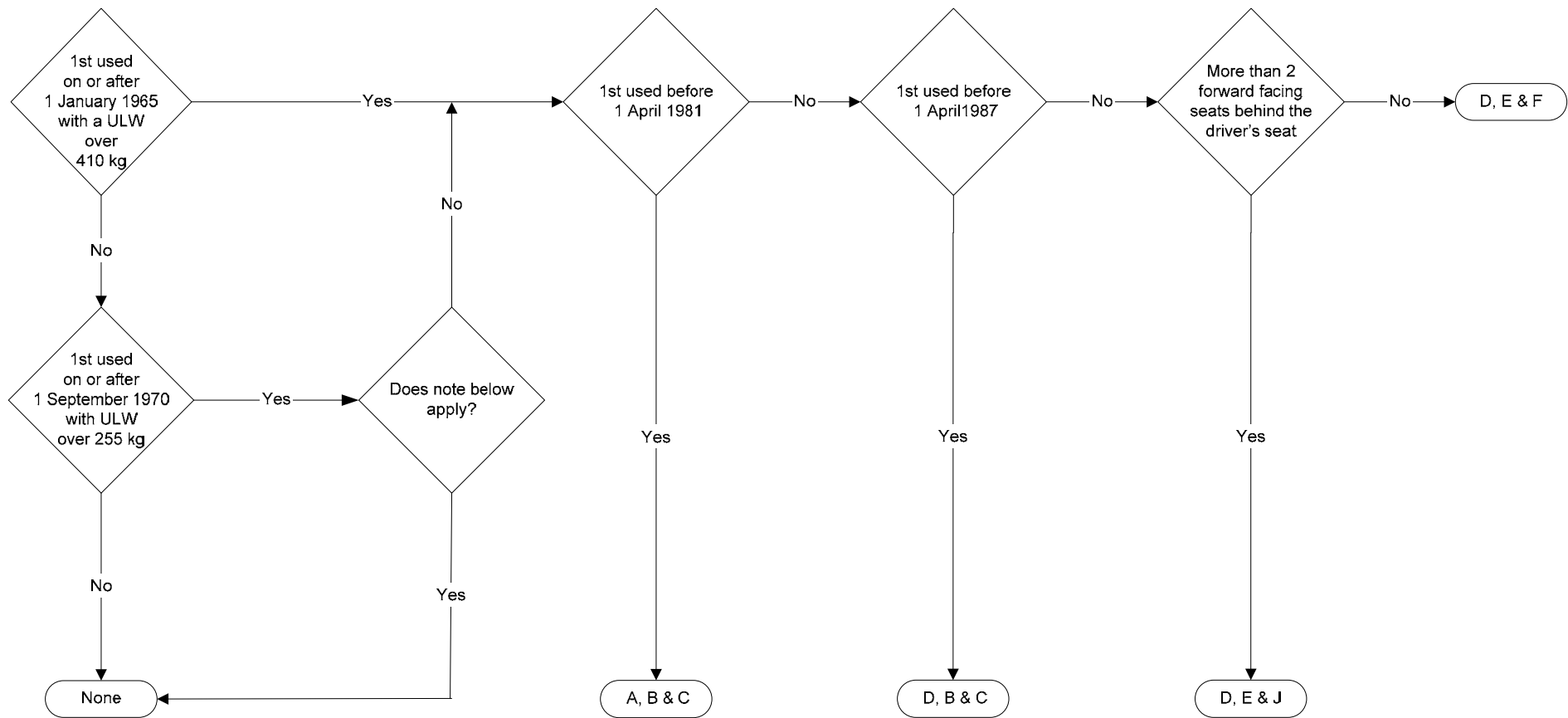

Note: Except for amateur built vehicles less than 410kg unladen weight , equipped with a driving seat of a type requiring the driver to sit astride it.

5.1 Seat Belt Requirements

Passenger Vehicles, Motor Caravans & Ambulances with up to Eight Passenger Seats

Note: For Quadricycles see Section 9.5.

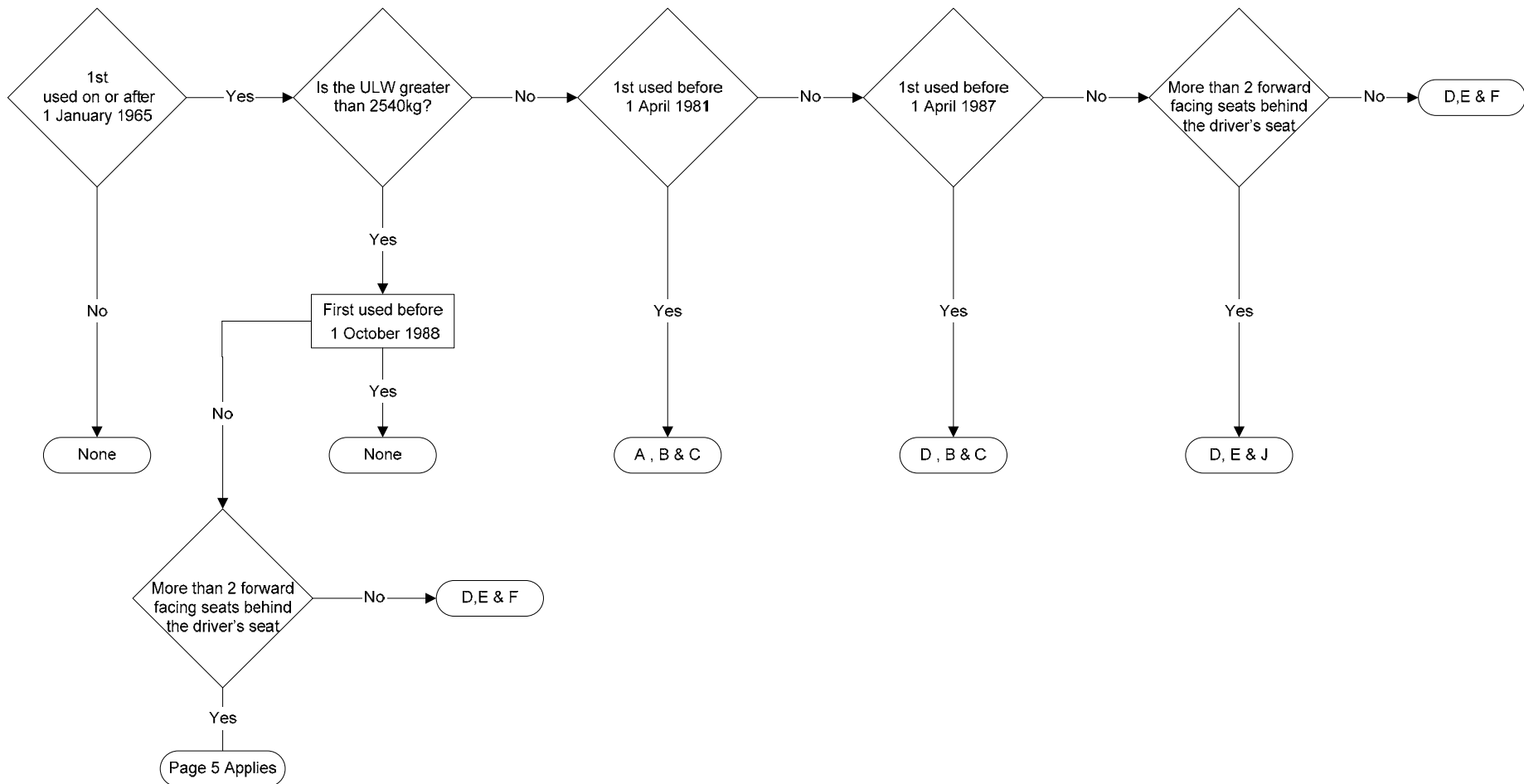

5.1 Seat Belt Requirements: Fitment

Minibuses, Motor Caravans & Ambulances with 9-12 Passenger Seats

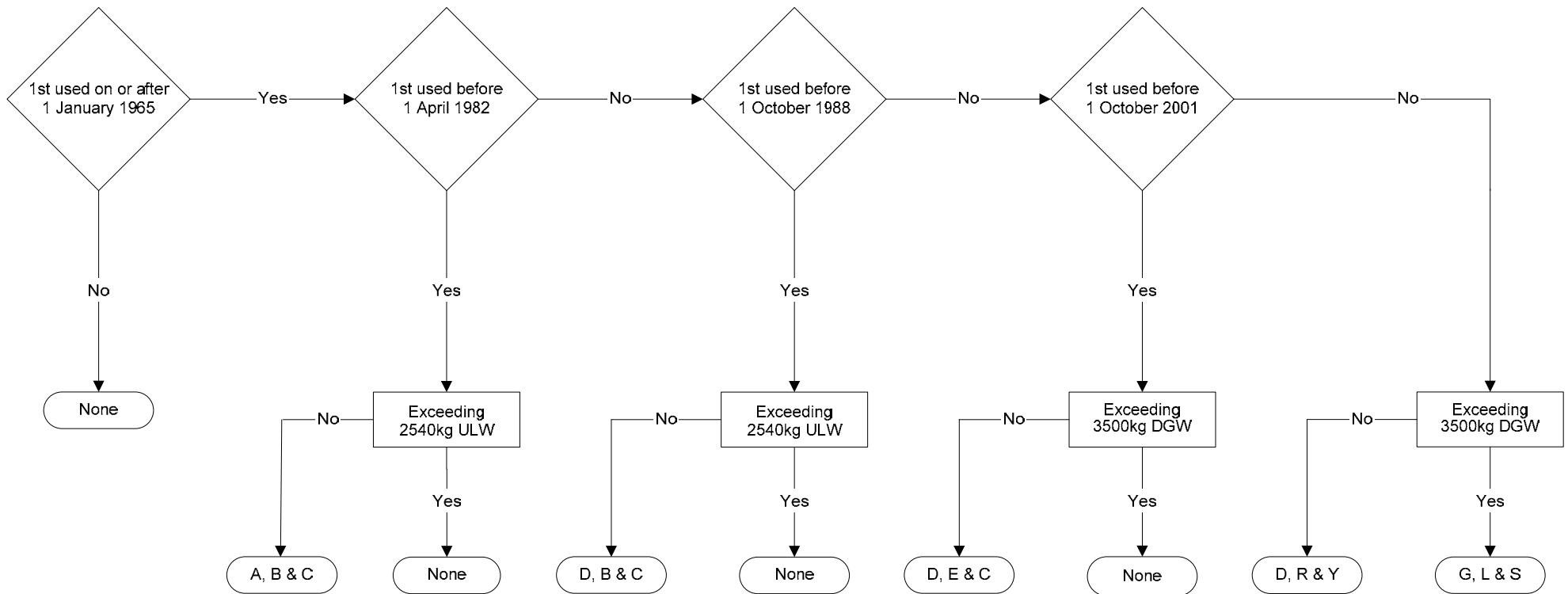

5.1 Seat Belt Requirements

Minibuses, Motor Caravans & Ambulances with 13-16 Passenger Seats

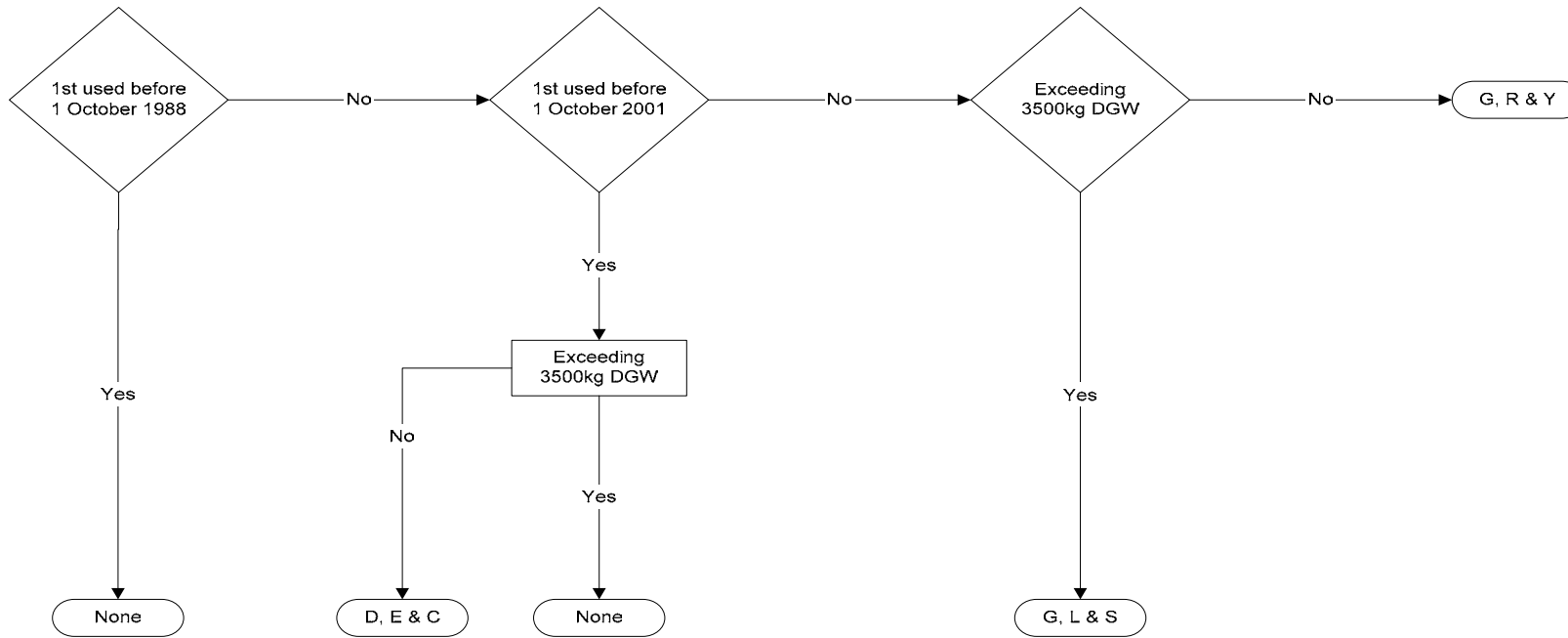

5.1 Seat Belt Requirements

Coaches

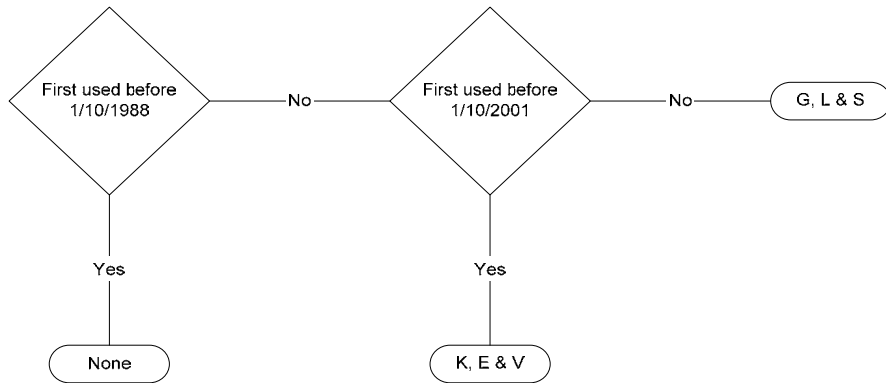

Other Buses (Except those designed for urban use with standing passengers or buses manufactured before 1st April 2001)

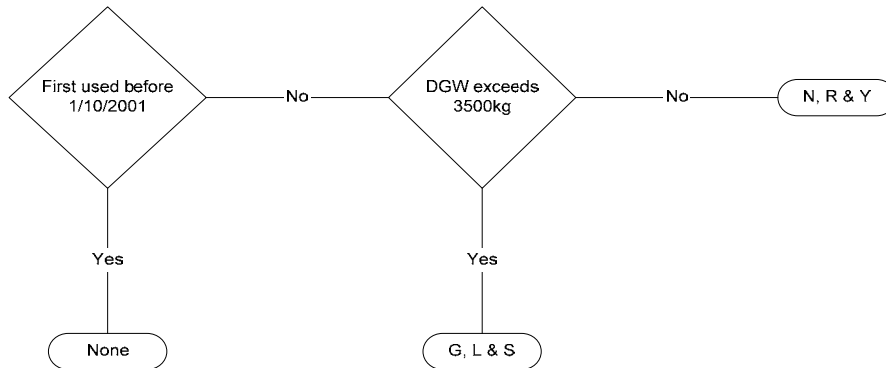

5.1 Seat Belt Requirements

Goods Vehicles & Living Vans

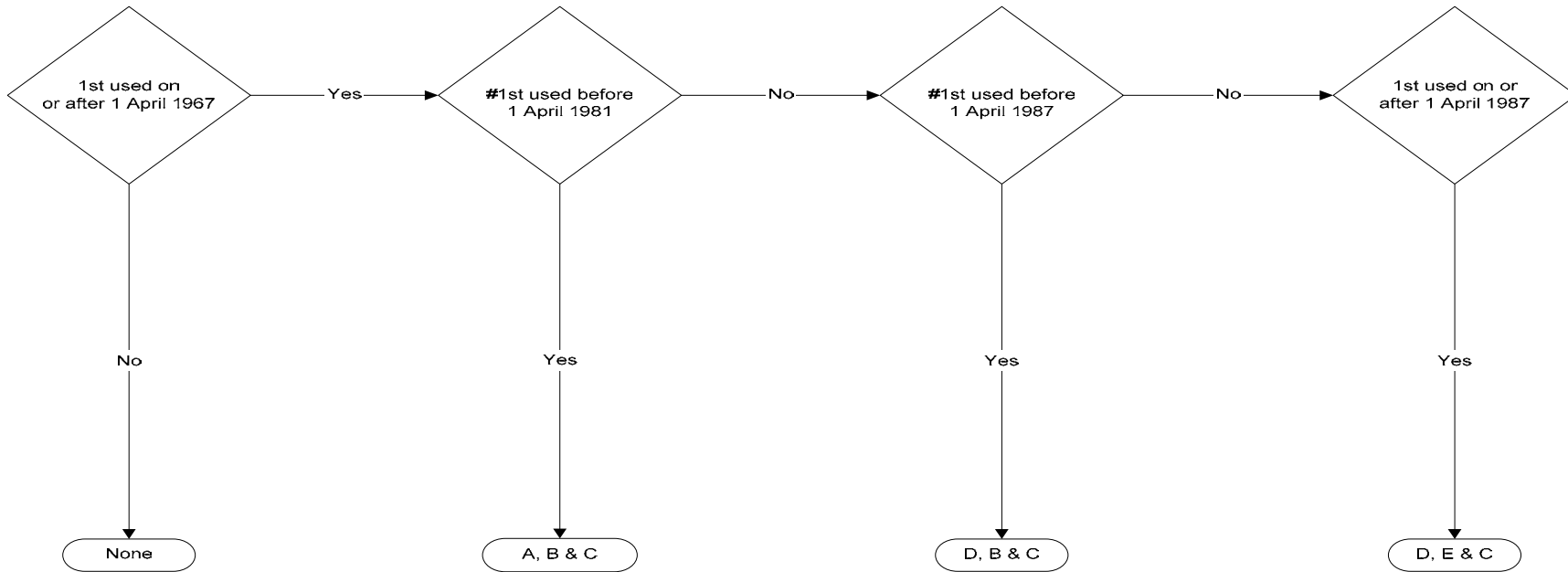

Except those with an ULW exceeding 1525kg and first used before 1 April 1980 or a model of vehicle which was manufactured before 1 October 1979, first used before 1st April 1982

5.1 Seat Belt Requirements

	Driver's & specified front passenger seat (See notes on Page 2)		Other forward facing front passenger seats (Where fitted)		Rear seats (See notes on Page 2)
A	A belt which restrains the upper part of the body (but need not include a lap belt).	B	None.	C	None.
D	A 3 point belt.	E	Any of the following: <ul style="list-style-type: none"> a. 3 point belt b. lap belt c. disabled person's belt. 	F	In forward facing rear seats: <ul style="list-style-type: none"> a. 3 point inertia reel belt in at least one seat, or b. any of the following in both seats: <ul style="list-style-type: none"> • a three point belt • a lap belt • a disabled person's belt.
G	Any of the following: <ul style="list-style-type: none"> a. 3 point inertia reel belt b. retractable lap belt c. disabled person's belt d. child restraint. <p>Note: Child restraints are not acceptable for driver's seats.</p>	H	Any of the following: <ul style="list-style-type: none"> a. 3 point inertia reel belt b. lap belt c. disabled person's belt. 	J	In forward facing rear seats any of the following: <ul style="list-style-type: none"> a. 3 point inertia reel belt on an outboard seat and a 3 point static or inertia reel belt, lap belt, disabled persons belt or child restraint for at least one other seat; or b. static 3 point belt for one seat and a disabled person's belt or child restraint for at least one other seat; or c. 3 point belt, lap belt, disabled person's belt or child restraint to each seat.
K	For the driver's seat, any of the following: <ul style="list-style-type: none"> a. 3 point belt b. lap belt c. disabled person's belt. <p>Note: There is no requirement for the specified front passenger seat to have a belt.</p>	L	Any of the following: <ul style="list-style-type: none"> a. 3 point inertia reel belt b. retractable lap belt c. disabled person's belt. d. child restraint 	M	In forward and rearward facing rear seats any of the following: <ul style="list-style-type: none"> a. 3 point inertia reel belt b. disabled persons belt c. child restraint.

5.1 Seat Belt Requirements

	Driver's & specified front passenger seat (See notes on Page 2)		Other forward facing front passenger seats (Where fitted)		Rear seats (See notes on Page 2)
N	Any of the following: <ul style="list-style-type: none"> a. 3 point inertia reel belt b. disabled person's belt c. child restraint. Note: Child restraints are not acceptable for driver's seats.	O	3 point belt or lap belt.	P	Any of the following: <ul style="list-style-type: none"> a. 3 point inertia reel belt b. retractable lap belt c. disabled person's belt d. child restraint.
Q	This section has been intentionally left blank for future use.	R	3 point inertia reel belt, disabled person's belt or child restraint.	S	Any of the following: <ul style="list-style-type: none"> a. 3 point inertia reel belt b. retractable lap belt c. disabled person's belt d. child restraint. Note: Retractable lap belts may be fitted on any exposed seat where there are no seats or surfaces directly in front. They are acceptable on non exposed seats only if an appropriate energy absorbing seat or surface is present in front.
T	This section has been intentionally left blank for future use.	U	This section has been intentionally left blank for future use.	V	In exposed forward facing seats (any rear seat which is not immediately behind a forward facing seat), a 3 point belt or lap belt.
W	This section has been intentionally left blank for future use.	X	This section has been intentionally left blank for future use.	Y	In forward facing rear seats any of the following: <ul style="list-style-type: none"> a. 3 point inertia reel belt b. disabled person's belt c. child restraint. Additionally, in rearward facing seats, retractable lap belts are also permitted.

5.2 Seat Belt Condition

Information	Method of Inspection	Reason for Rejection
<p>This inspection applies to all seat belts fitted including child seats/restraints etc. However the reasons for rejection should only be applied to those permanently attached to the vehicle ie secured by using Isofix mountings or nuts, bolt etc. Presenters should be advised of any effects on non-testable items.</p> <p>Child seat(s) retained by seat belt(s) must not be removed. A visual examination is required of only those parts of the seat belt(s) which are readily accessible.</p> <p>A seat belt installation check may be required on vehicles, fitted with more than 8 passenger seats, first used before 1 October 2001. Refer to Section 5.3 for further information.</p> <p>Where a belt is fitted with no corresponding seat or if there is a buckle/stalk but no corresponding belt, it is NOT to be considered a seat belt for the purpose of this inspection.</p> <p>Every effort should be made to lift folded seats to facilitate the inspection of seat belts provided this does not require the use of tools or specialist equipment. However, this is not mandatory where it would be unreasonable, such as due to the presence of heavy, fragile or numerous passenger effects or other articles.</p> <p style="text-align: right;">Cont'd ↓</p>	<p>Condition of ALL seat belts fitted</p> <ol style="list-style-type: none"> 1. Pull each seat belt webbing against its anchorage to see that it is properly secured to the vehicle structure. 2. Examine the condition of all seat belt webbing for cuts or obvious signs of deterioration. Pay particular attention to webbing around anchorages, buckles and loops. 3. Examine the condition of all seat belt attachment and adjustment fittings. <p style="text-align: right;">Cont'd ↓</p>	<p>Reason for Rejection</p> <ol style="list-style-type: none"> 1. <ol style="list-style-type: none"> a. A seat belt not securely fixed to the seat or to the structure of the vehicle. For example, a fixing bolt not secure b. for seats with seat belts attached to them: <ul style="list-style-type: none"> • any insecure attachment of the seat to the vehicle structure • a seat frame cracked • any damage that significantly weakens the seat frame. 2. A seat belt: <ol style="list-style-type: none"> a. cut or damaged sufficient to obstruct correct operation of the belt or significantly weaken the webbing b. stitching badly frayed, not secure or incomplete c. which has obviously been repaired 3. A seat belt attachment or adjustment fitting fractured or badly deteriorated. <p>Note: Damage or deterioration of the plastic covering of a component is not a reason for rejection unless it affects the operation of the belt.</p> <p style="text-align: right;">Cont'd ↓</p>

5.2 Seat Belt Condition

Information	Method of Inspection	Reason for Rejection
<p>Some types of retracting belt might need manual help before they retract.</p> <p>The vehicle presenter should be advised of and given the opportunity to remove any temporarily fitted device likely to cause failure before notification of refusal is issued.</p> <p>Where a seat belt is attached to a seat frame, ALL seat mounting points are considered to be seat belt mounting points.</p>	<p>4. Examine flexible buckle stalks for corrosion, deterioration or damage.</p> <p>5.</p> <ul style="list-style-type: none">a. Fasten each belt locking mechanism and try to pull the locked sections apart. Operate the release mechanism while pulling on the belt to check that the mechanism releases when requiredb. on retracting seat belts, check that with the mechanism fastened and the seat unoccupied, excess webbing is wound into the retracting unit. <p>Note: In doubtful cases, this should be checked with the seat base set in its rearmost position.</p> <p>6. As far as is practicable without dismantling, check the condition of the vehicle structure around the seat belt anchorage points. The floor-mounted anchorage points might need to be inspected from underneath the vehicle.</p>	<p>4.</p> <ul style="list-style-type: none">a. Corrosion, deterioration or damage of a flexible stalk likely to lead to failure under loadb. broken strands of a flexible stalk cable. <p>5.</p> <ul style="list-style-type: none">a. The locking mechanism of a seat belt does not secure or release as intendedb. a retracting mechanism does not retract the webbing sufficiently to remove all the slack from the belt with the locking mechanism fastened and the seat unoccupied. <p>6. Deliberate modification which significantly reduces the original strength, excessive corrosion, severe distortion, a fracture or an inadequate repair of a load bearing member or its supporting structure or supporting panelling within 30cm of a seat belt anchorage, (ie, within a 'prescribed area', see Appendix C.)</p>

Seat Belt Installation Requirements (Class 4A & 5A approved VTS only)

Vehicles fitted with more than 8 passenger seats and first used before 1 October 2001 may be subject to a seat belt installation check.

This can only be carried out by full Class 5 authorised test stations. It is essential therefore that you correctly identify vehicles that require a seat belt installation check.

A vehicle will require a seat belt installation check if:

- it has more than 8 passenger seats fitted (see note below) **and**
- it has more than the legally required number of seat belts fitted (as per charts on pages 5 to 7 of Section 5.1) **and**
- there is no proof that all the seat belt anchorage points have been type approved (see page 3) **or**
- there is no proof that a seat belt installation check has been previously carried out (this will be by a previous VT 20 being produced at time of test showing that the vehicle has had an installation check) **or**
- extra seat belts have been fitted since a previous MOT installation check (Compare the number of seat belts now fitted with the number shown on the last MOT certificate).

Note: If it is obvious that the vehicle is capable of carrying more than 8 seated passengers (for example, by having wheelchair tracking/clamps fitted) the presenter of the vehicle should be asked how many passengers the vehicle carries in normal use to establish the seating capacity.

5.3 Seat Belt Installation Check

Information	Method of Inspection	Reason for Rejection
<p>For vehicles first used before 1 October 2001 to be exempt from the check, they must have been fitted with a type approved seat belt installation by the vehicle manufacturer when new.</p> <p>If you are aware that any of the following vehicles have had any seats/seat belts fitted by any other installer, e.g. where it has been adapted to carry wheelchairs and has removable seats on tracking, it will not be exempt and will require an installation check.</p> <p>Type approved seat belt installations can be identified as follows:</p> <p>Ford Transits:</p> <ul style="list-style-type: none"> • 12 and 15 seat (including the driver) Transits manufactured after 1 October 1991 where the fourth character of the VIN Number is “E” • 17 seat (including the driver) Transits where there is a six figure code EJA*CL or EJJ*CL marked in the top right hand of the manufacture’s plate (in the type code box). In the code the fourth digit marked * can be any character. <p>Land Rover Defender 110 Station Wagon:</p> <ul style="list-style-type: none"> • manufactured 1990 - from chassis number 455758 • manufactured 1991 onwards - all chassis numbers. <p style="text-align: right;">Cont’d ↓</p>	<p>Installation check</p> <ol style="list-style-type: none"> 1. Inspect the installation of each non-statutory seat belt mounting, referring to the guidance notes in this Section AND the seat belt installation amplification note pack held at each class 5 Test Station and diagrams to be found at the end of this Section. <p>Note: This inspection can only be carried out by a vehicle test station authorised for classes 4A and 5A.</p>	<ol style="list-style-type: none"> 1. <ol style="list-style-type: none"> a. Evidence that original webbing has been cut and/or reworked; eg belts knotted, fraying or fluffing removed/ sealed by burning etc (see note A) b. any part of the installation which has a sharp edge which could or is likely to cut or abrade the webbing c. a directly attached anchorage not secured by standard seat belt mounting bolts and washers as detailed in note D d. an anchorage insecure e. a tubular seat frame that has been drilled for the purpose of attaching a seat belt (see note E) f. a directly attached anchorage not attached to a load bearing member or without suitable reinforcement (see notes I, N and O) g. retro-fitted three point belt which is not mounted on a suitable structure (see diagram 5) h. tubular frame legs or tubular “H” pattern legs which have not been reinforced with buttressing and diagonal bracing (see diagram 6), or buttressing where a floor mounted belt is fitted close to a seat leg i. retro-fitted three point belt fitted to a seat on which the leg and frame has not been suitably modified (see note J) j. rail or other harsh object without suitable padding as required at note L k. lower anchorage’s less than 320mm apart (see note M) <p style="text-align: right;">Cont’d ↓</p>

5.3 Seat Belt Installation Check

Information		Reason for Rejection
<p>LDV 200 series:</p> <ul style="list-style-type: none">chassis number from 933478 onwards and the seventh character of the VIN number is "S". <p>LDV 400 series:</p> <ul style="list-style-type: none">chassis number from 933478 onwards and the seventh character of the VIN number is "S" or "V". <p>LDV Pilot and Convoy:</p> <ul style="list-style-type: none">chassis number from 000001 onwards and the seventh character of the VIN number is "S" or "X" <p>Mellor bodied Renault Master:</p> <ul style="list-style-type: none">on production of a PSV certificate of conformity (PSV 408).		<p>Reason for Rejection</p> <ul style="list-style-type: none">l. in such a position that loading the belt causes the cushion to be raised or significantly compressed thus allowing the occupant effectively to move forwardm. an anchorage attached to the floor without reinforcement plates of a suitable size and contour (see notes N and O)n. with load spreading washer(s) missing from anchorage bolt (see note H)o. claw type seat mounting with inadequate means of securing claw (see note Q)p. on a seat fitted to a flat rail the bolt does not pass through the leg, rail, floor, and a suitable structural member, or the floor has not been suitably reinforcedq. tracking for seats and wheelchairs insecure (see note S)r. free movement for a looped belt more than 25mm at the anchorages. upper anchorage of three point belt less than 475mm above uncompressed seat cushion measured parallel to the seat back (see note V)t. upper anchorage of three point belt(s) less than 110mm from centre line of seat (see note V)u. incorrect positioning of a lap belt or lap section of a three point belt, ie the belt lies across the stomach or forward of the top quarter of the thighv. a seat belt component fitted to a seat significantly intrudes into a gangway and is likely to cause injury to a passenger.

5.3 Seat Belt Installation Guidance Notes

Notes

All belts should be checked for installation, operation and wear, except the following categories which shall be checked for operation and wear only:

1. Seat belts provided for rear or side facing seats.
2. Disabled person's belts which are permanently attached to the vehicle.
3. Child restraints which are permanently attached to the vehicle.
4. Obligatory seat belts as specified on pages 3 to 10 of Section 5.1.

No check is required for disabled person's belts or child restraints which are not permanently attached to the vehicle.

It will be necessary to ask the operator to remove seat cushions and to open any access flap or luggage locker door, which was designed to be capable of being readily opened, to allow as much as possible of the seat belt installation to be seen.

Some parts of the installation may only be visible with the vehicle on a pit or hoist.

Where a vehicle is fitted with a type approved belt installation it will not be necessary to carry out an installation check. These belts are at present only likely to be fitted to purpose built minibuses with factory installed belts. Details of the vehicles which are fitted with type approved seat belts are shown on page 3 of this section.

If an operator has been provided with documentary evidence to show that a seat belt complies with type approval standards (but has not been fully type approved) or that is traceable to an installation tested and shown to meet the requirements of ECE Regulation 14 or Community Directive 76/115 it should be produced at the time of test.

It should show registration number or chassis number of the vehicle and the name and address of the installer. It should also show the test number and the date and location of the test of the installation.

Original certificates are required. Photocopies are not acceptable. Presentation of the certificate would not replace the need for the examination to be conducted but it may support the quality of the installation and help resolve differences over the acceptability of the installation, e.g. reinforcement plates used.

Diagram 1 on page 9 of this section shows typical methods of attaching seat belts.

Where the word close is used it should generally be regarded as 50mm or less.

- A. Check that on all belts the buckle operates correctly and the seat belt adjusts satisfactorily. Subsequent cutting or reworking of the webbing will be a reason for failure.

It is acceptable for the free end of looped belts or static belts to be reworked to the extent of folding and stitching the webbing so that it cannot pass back through the buckle to prevent the buckle from being dismantled. Any knots in the belt webbing are unacceptable.

- B. Seat squabs should be removed, to aid the inspection of the condition of the belt and mountings. They must be replaced before the end of the test to allow inspection of the complete belt installation.
- C. Check for the presence of any sharp edges which the belt could rub on or pull across during use.
- D. Where seat belts, other than looped belts, are anchored to the seat frame or the vehicle floor they must be secured with mounting bolts in accordance with the following:

Cont'd ↓

5.3 Seat Belt Installation Guidance Notes

Notes

Minimum Acceptable Size and Grade of Bolts for Seat Belt Anchorage's

Type of Anchorage	Minibus	Coach or Large Bus
Single Anchorage	M10 Standard Material	M8 High Tensile Steel M10 Standard Material
Double Anchorage	7/16" Standard Material M10 High Tensile Steel	7/16" Standard Material M10 High Tensile Steel

Note: Bolt head marks:

- Standard Material = P, 4.6 or SAE equivalent
- High Tensile Steel = S, 8.8 or SAE equivalent
- No Markings = Standard Material

If the examiner cannot determine the grade of bolt it must be assumed to be of Standard Grade.

It is paramount that the appropriated sized bolt is used in the seat belt anchorage, i.e. an 8mm bolt should not be used in an 11.5mm diameter hole. The only exception to this is where there is a "stepped washer" or collar used to eliminate the excessive clearance and a suitable washer is fitted between the bolt head and the anchorage to prevent the bolt pulling through.

The use of smaller bolts, self tapping screws or wood screws is not acceptable.

- E. It is not acceptable to drill tubular seat frames to allow belts to be bolted to the frame except in cases where a manufacturer has approved the installation and the operator presents a certificate issued by the manufacturer or their agent declaring that the installation is satisfactory.
- F. Clamp type brackets are acceptable provided they are properly secured.
- G. On seats constructed with a wooden frame it is unacceptable to mount the belts either directly to the frame or to a metal base which is attached to the frame only by wood screws. Unless there are additional reinforcement brackets fitted that provide a direct load path to the seat and leg and side mounting, the installation would be rejected.

This reinforcement could take the form of steel angle sections or plates, alternative materials may be used provided they are of comparable strength (see Diagrams 3 & 4 for details of a typical installation).
- H. Where seat belts are attached to thin sheet metal frames the bolts anchoring the belt must be of the minimum dimensions shown in note D and must be adequately supported by the use of load spreading washers between the frame and the nut.

Typically this would be 25mm in diameter and 2mm thick. If two belts are attached at the same point with a single bolt then a larger reinforcement plate 35mm diameter x 3mm thick (or a rectangular plate of minimum dimensions 21x46x3mm) must be used. The sizes quoted are for steel reinforcement plates, alternative materials may be used but must provide comparable strength.

- I. Where seat belts are fitted in the rear seats of a vehicle check the anchorage to ensure that it is not anchored solely to the thin metal sheet which separates the boot area from the passenger compartment. It is essential that seat belt anchorages be secured to a strong cross member connected to the structural members of the vehicle.

The connection should be to such a standard that there is confidence that it will be able to transfer the seat belt loads into the structure of the vehicle. This may involve the fabrication of an additional framework at the rear of the vehicle.

An example of typical reinforcement of this area would be by the use of additional square section tubing 40x40x3mm, or angle plate 50x50x4mm across the full width of the vehicle.

The sizes quoted are for steel reinforcement; alternative materials may be used but must provide comparable strength. A full width reinforcement that is only attached to the thin metal sheet is unacceptable and would be a reason for failure.

Cont'd ↓

5.3 Seat Belt Installation Guidance Notes

Notes

- J. Three point belts will only be accepted under the following circumstances:
 - If the seat utilises tubular frames or tubular “H” pattern legs:
 - The seats have been reinforced as detailed in note K, or
 - A purpose built structure to which belts are attached is fitted to the vehicle, an example is shown in diagram 5, alternatively the belts may be attached to solid bodywork
 - or, if purpose made seats designed with integral three point belts as standard have been fitted.

- K. Where seats that are permanently mounted in the vehicle have been fitted with lap belts or 3 point belts integral to the seat, then, if the seat utilises tubular frames or tubular “H” pattern legs it must be reinforced.

This will include welding metal buttresses, of similar thickness material as the foot, between the foot and the leg (see diagram 6). Also the welding of a diagonal brace, either in compression or tension, between the foot and the seat base attachment of each leg.

Alternatively documentary evidence of compliance with Directive 76/115 or ECE Regulation 14 can be presented.

On quick release seats where the feet are mounted directly to tracking by a coupling it may not be practical to weld a buttress to the leg or a diagonal brace to the foot due to the presence of the coupling (see diagram 7).

The coupling would prevent any reinforcement being placed in an effective position, also the coupling could be damaged if welding occurred close to it. On this type of installation the belts can be attached directly to the tracking with quick release mounts or the legs should be modified to use an alternative method of attachment to the tracking.

On seats where the feet are mounted to a metal bar or tube which is then connected to tracking by a quick release coupling, then the seat has to be reinforced with buttresses and diagonal brace as detailed above.

On vehicles with floor mounted seat belts where the belt is anchored close to the seat mounting bolt then the rear foot of each leg must be buttressed to the leg.

- L. If lap belts are fitted and there is the possibility of passengers hitting their heads on any harsh object such as a grab rail or seat stanchion, padding or other suitable protection must be provided on these objects.

The protection does not need to cover the full length of a seat grab rail but should cover a length of at least 300mm directly in front of each passenger.

Padding must be compressible, of a depth of at least 50mm measured to the surface of the bar and not compress more than 25mm under reasonable thumb pressure; or 25mm thick, and not compress more than 5mm. Ordinary seat foam or pipe lagging is unlikely to be of sufficient density for this purpose.

- M. Lower anchorages should be at least 320mm apart. This need not be the distance between the anchorage points of the belt but it can be between two structural parts of the seat that the belt is routed round.

If the measurement is between mounting bolts it should be measured between bolt centres.

Check that the belt will not raise or significantly compress the seat cushion when subjected to a load. There will always be a small amount of compression which is acceptable.

Cont'd ↓

5.3 Seat Belt Installation Guidance Notes

Notes

N. Where belts are attached directly to a metal floor, a load spreading washer must be used between the nut and the floor.

The bolts must be of the sizes specified in note D. Typically this would be 25mm in diameter and 2mm thick. If two belts are attached at the same point with a single bolt then a larger reinforcement plate of minimum dimensions 35mm diameter and 3mm thick (or a rectangular plate of minimum dimensions 21x46x3mm) must be used.

The sizes quoted are for steel reinforcement plates; alternative materials may be used but must provide comparable strength.

Reinforcement plates should follow, as far as practicable, any contours in the floor to which they are attached.

O. Where a belt is attached directly to a wooden floor each anchorage must be reinforced with a plate of minimum dimensions 35mm diameter x 3mm thick (or a rectangular plate of minimum dimensions 21x46x3mm).

If two belts are attached at the same point with a single bolt then the reinforcement plate must have minimum dimensions of 92mm diameter x 3mm thick (or a rectangular plate of minimum dimensions 65x100x3mm).

If two belts are attached in close proximity to each other, then a single reinforcement plate of minimum dimensions 92mm diameter x 3mm thick (or a rectangular plate of minimum dimensions 65x100x3mm) should be used ensuring that the bolt holes are not too close to the plate edge.

Alternatively two steel reinforcement plates may be used but they must be of minimum dimensions 52mm diameter x 3mm thick (or a rectangular plate of minimum dimensions 46x46x3mm).

The sizes quoted are for steel reinforcement plates; alternative materials may be used but must provide comparable strength. Reinforcement plates should follow, as far as practicable, any contours in the floor to which they are attached.

P. Where mounting rails designed for the adjustment of seat pitch are fitted and utilise an angled claw type clamp (see Diagram 8) with a clamping face of less than 15mm wide it is not acceptable for a seat on which a belt is mounted to be merely clamped to the rail.

The clamp to the rear foot of each leg must be modified by fitting a bolt through each claw fitting. The bolt must clamp the rear foot of each leg to the rail, floor and a suitable structural member (as in most vehicles).

The bolts must have appropriately sized load spreading washers fitted beneath the bolt head and underneath the retaining nut. A single bolt should be not less than 8mm (5/16") diameter. Any alternative to this is only acceptable if documentary evidence is provided.

Q. Parallel type claw fittings, for a seat on which a belt is mounted, will be considered satisfactory provided that the securing bolts are fully tightened (see Diagram 9).

R. If a seat, on which a belt is mounted, is bolted to a flat rail the bolts must pass through the leg, rail, floor and a suitable structural member.

S. It is acceptable for seats to be attached to a purpose built tracking (e.g. keyhole, "T" slot, see diagram 2) designed for securing seats and wheel chairs, providing the tracking is securely attached to the vehicle structure with bolts or fasteners in **all** the retaining holes or marks provided by the manufacturers.

Cont'd ↓

5.3 Seat Belt Installation Guidance Notes

Notes

- T. It is unacceptable to fit seats, with seat belts, directly to unsupported wooden floors unless additional reinforcement is provided.

This will involve the fitting of steel reinforcement plates of minimum dimensions 92mm diameter x 3mm thick (or a rectangular plate of minimum dimensions 65x100x3mm), between the under side of the floor and the securing nut below the floor of the rear leg and between the leg and the top side of the floor of the front leg.

If the area of the foot of the front leg is greater than 65x100mm, then the front reinforcement plate is unnecessary.

- U. A “looped” type seat belt fitting is acceptable provided it is not free to float along any part of the seat structure. Any free movement in excess of 25mm is a reason for failure.

- V. The upper anchorage point should be at least 475mm above the height of an uncompressed seat cushion. This dimension is to be measured parallel to the backrest.

The upper anchorage point should be a minimum of 110mm from the centre line of the seat back to the side of the seat.

- W. A lap belt or the lap section of a 3 point belt must be positioned to lie across the wearer’s pelvis and not the stomach. This is to reduce the risk of abdominal injury and to prevent “submarining”. In practise this may result in the belt lying across the top quarter of the thigh.

- X. Seat belt components should not be fitted to seats in such a way that they significantly intrude into the gangway space and are likely to cause injury to passengers by either tripping or by hitting the component.

Cont'd ↓

5.3 Seat Belt Installation Guidance Notes

Diagram 1: Typical Methods of Attaching Seat Belts

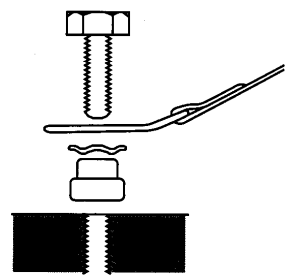

Direct attachment to floor

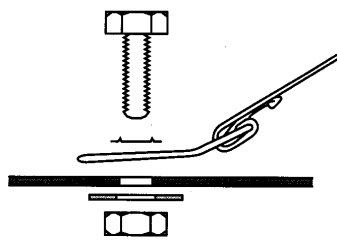

Direct attachment to seat frame

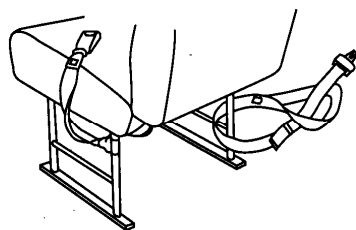

Installation of looped seat

When installed, free movement must not exceed 25mm

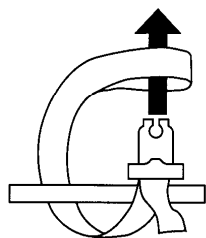

Method of attaching looped seat belt

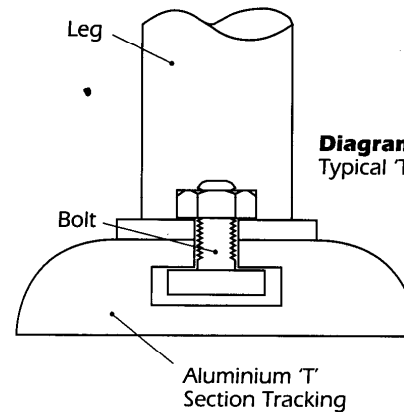

Diagram 2
Typical T Bolt Fitting

Cont'd ↓

5.3 Seat Belt Installation Guidance Notes

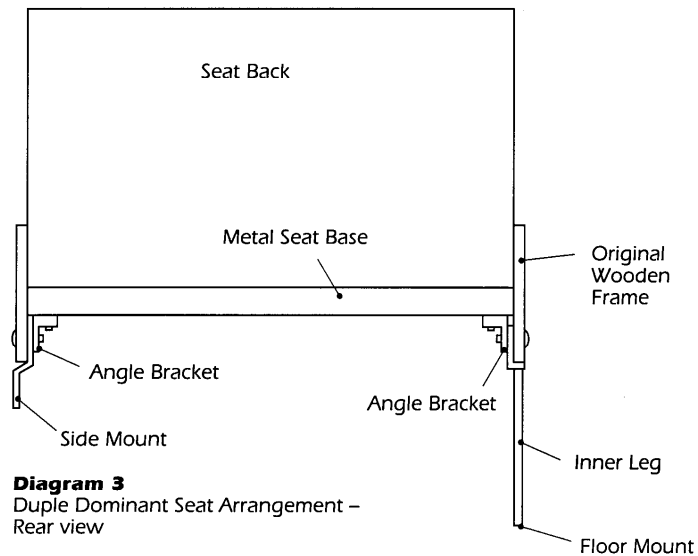

Diagram 3
Duple Dominant Seat Arrangement –
Rear view

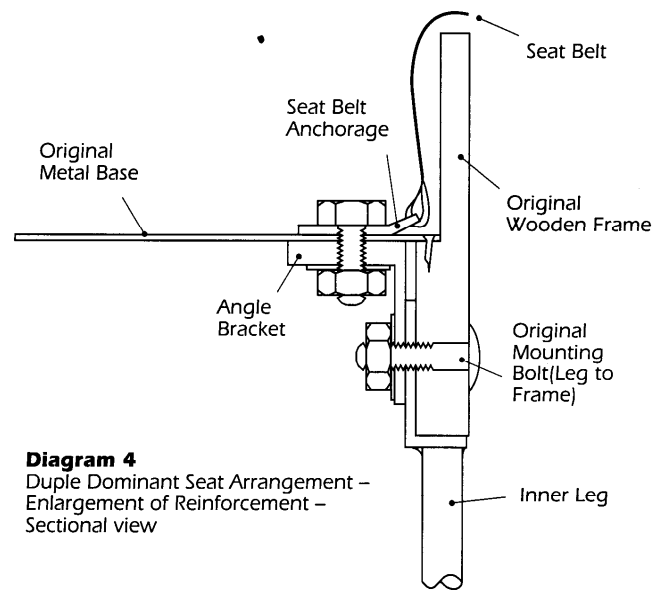
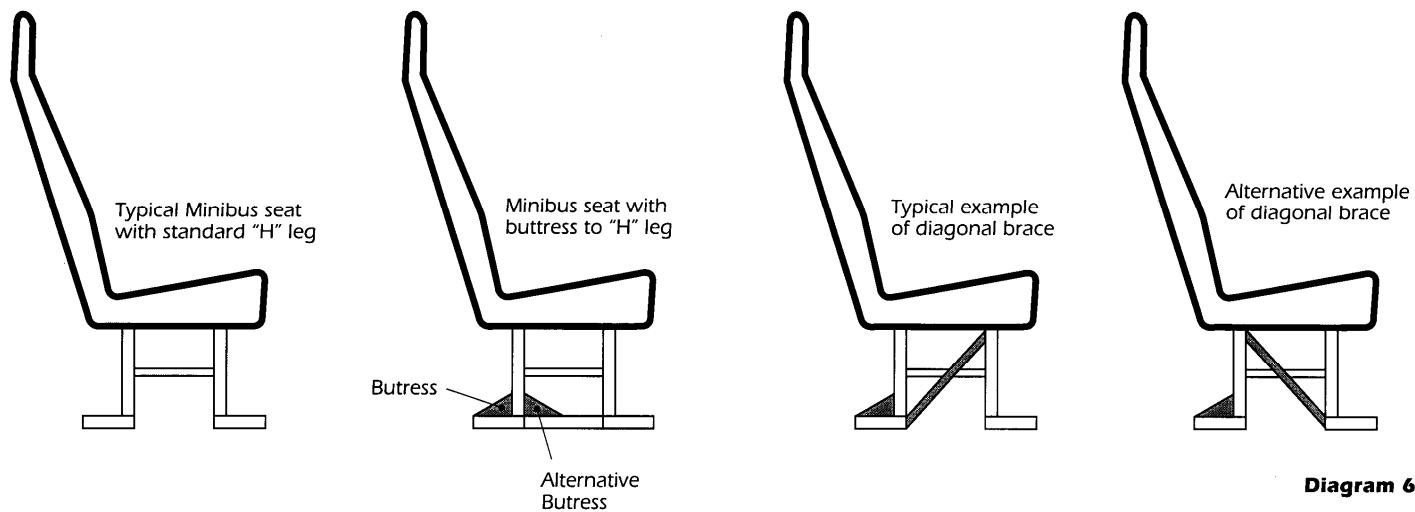
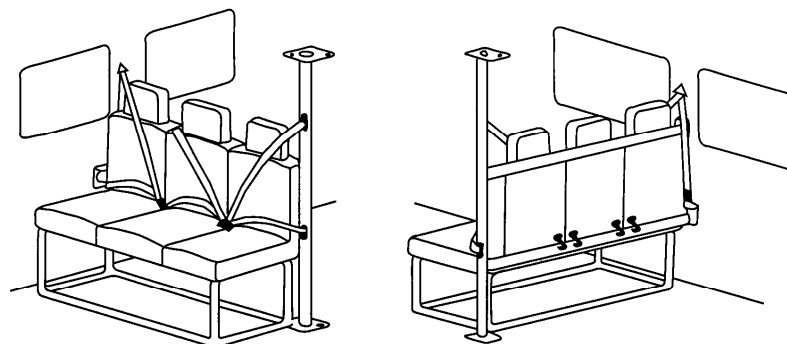

Diagram 4
Duple Dominant Seat Arrangement –
Enlargement of Reinforcement –
Sectional view

Cont'd ↓

5.3 Seat Belt Installation Guidance Notes

Diagram 5



Cont'd ↓

5.3 Seat Belt Installation Guidance Notes

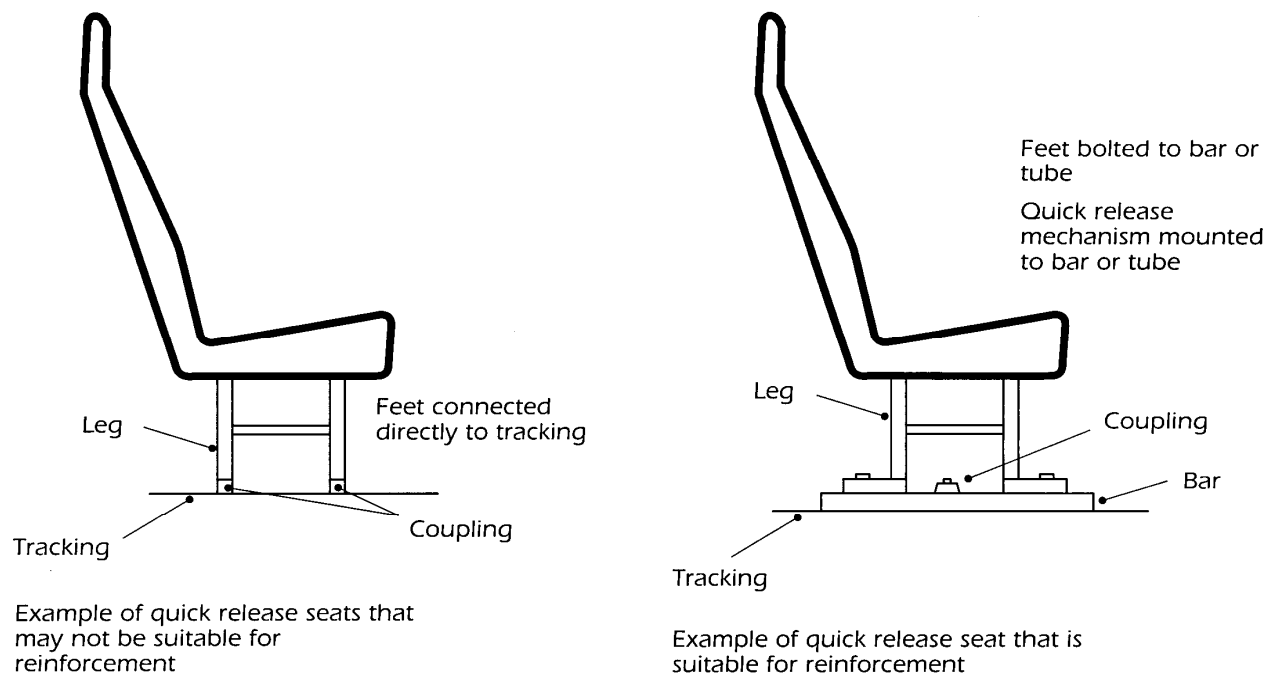

Diagram 7

Cont'd ↓

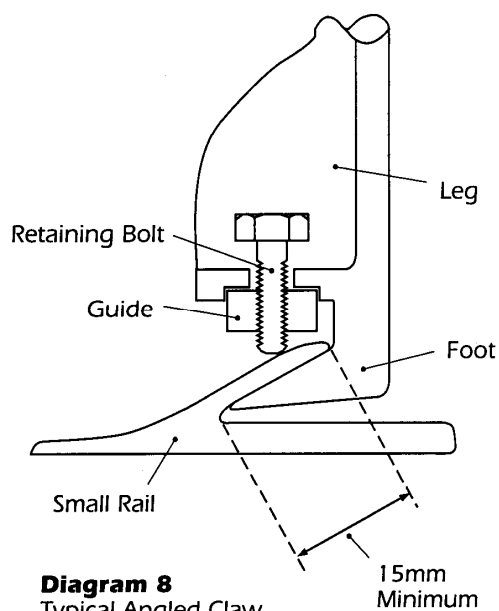

Diagram 8
Typical Angled Claw Fitting

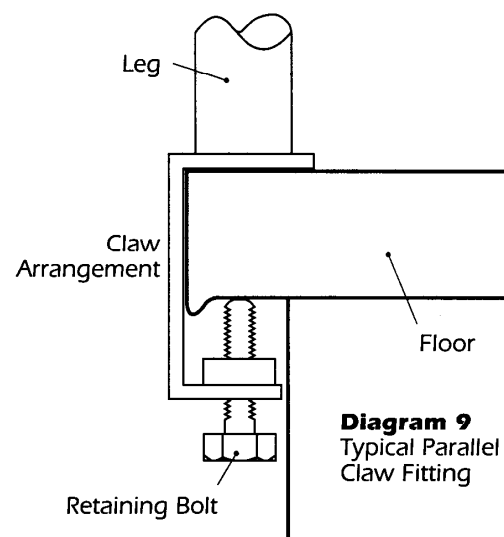



Diagram 9
Typical Parallel Claw Fitting

5.4 Supplementary Restraint Systems (SRS)

Information	Method of Inspection	Reason for Rejection
<p>This inspection applies to airbags, seat belt pretensioners and seat belt load limiters fitted as original equipment other than on Class 3 vehicles.</p> <p>The SRS malfunction indicator lamp (MIL) may display a symbol similar to that shown below, or one depicting a person wearing a seat belt. Alternatively, the letters SRS or another symbol may be displayed.</p>  <p>Seat belt load limiters are used on some vehicles to minimise seat belt inflicted injury in violent collisions. This is generally achieved by releasing a little more excess belt webbing when a great deal of force is applied to the belt.</p> <p>The simplest type of load limiter is a fold sewn into the belt webbing. The stitches holding the fold in place are designed to come apart when a high amount of force is applied to the belt, thereby releasing an extra bit of webbing.</p> <p>A more commonly used limiter is a mechanical type, such as those which use a torsion bar in the retractor mechanism. These cannot usually be readily seen or inspected.</p> <p>Seat belt pretensioners may be fitted to some seat belts. Once activated a warning device may display.</p>	<p>Method of Inspection</p> <ol style="list-style-type: none">1. As far as practicable, check that all airbags fitted as original equipment are present and not obviously defective.2. Check that the Supplementary Restraint System (SRS) malfunction indicator lamp (MIL) does not indicate a fault in the system.3. Check the presence and condition of any seat belt load limiters and/or pretensioners fitted as original equipment.	<p>Reason for Rejection</p> <ol style="list-style-type: none">1. An airbag obviously missing or defective. Note: A passenger airbag that has been switched off is not a Reason for Rejection.2. A Supplementary Restraint System (SRS) malfunction indicator lamp indicating a system malfunction.3.<ol style="list-style-type: none">a. A seat belt load limiter or pretensioner obviously missing where fitted as original equipmentb. a seat belt pretensioner or a 'folded webbing' type load limiter obviously deployed.

Body, Structure and General Items

Section Contents

Sub-Section	Subject	Sub-Section	Subject
6.1	Vehicle Structure, Body and General Items <ul style="list-style-type: none">A. Vehicle StructureB. Body Security (Vehicles with separate bodies only)C. Body ConditionD. Engine MountingsE. Steps and Stairs (Class 5 only)	6.5	Speed Limiter <ul style="list-style-type: none">A. Speed Limiter PlateB. Speed Limiter
6.2	Seats and Doors <ul style="list-style-type: none">A. SeatsB. DoorsC. Passenger Entrance and Exit Doors (Class 5 only)D. Emergency Exits (Class 5 only)	6.6	Towbars
6.3	Registration Plates and Vehicle Identification Number <ul style="list-style-type: none">Registration PlatesVehicle Identification NumberRegistration Plates – Additional Information	6.7	Speedometer
6.4	Load Security, Spare Wheel and Carrier	6.8	Driving Controls (Class 5 only)
		6.9	Glazing (Class 5 only)

6.1 Vehicle Structure, Body and General Items

Information	Method of Inspection	Reason for Rejection
<p>Various typical vehicle structures are shown at figures 1 to 4 in Appendix C, where the shaded portions indicate the important load-bearing parts.</p> <p>Note: The prescribed areas are those specifically detailed in Sections 2, 3 and 5 of the Manual.</p> <p>Individual body security defects are not a Reason for Rejection unless their cumulative effect is likely to significantly reduce the overall body security.</p> <p>The inspection of body condition applies to all vehicles and includes body components such as bumpers, spoilers and mirror housings.</p> <p style="text-align: right;">Cont'd ↓</p>	<p>A. Vehicle Structure</p> <ol style="list-style-type: none"> 1. With the vehicle over a pit or on a raised hoist, check the vehicle structure for any fracture, damage or corrosion, not within the prescribed areas, which is likely to affect prejudicially the correct functioning of the braking system or the steering gear. <p>B. Body Security (applies to vehicles with separate bodies only)</p> <ol style="list-style-type: none"> 1. Examine the following items for presence, security, fracture, distortion, excessive wear or damage: <ol style="list-style-type: none"> a. all fixings (e.g. brackets) securing the body and its supporting members to the chassis b. all fixings (e.g. brackets) securing the body to a sub-frame or supporting members, and all securing bolts, rivets or welds for all the above fixings. 2. Check the condition of the body and chassis in the vicinity of the mounting points. <p>C. Body Condition</p> <ol style="list-style-type: none"> 1. Examine the body work for excessive corrosion or damage resulting in sharp edges which are likely to cause injury. <p style="text-align: right;">Cont'd ↓</p>	<p>Reason for Rejection</p> <ol style="list-style-type: none"> 1. Any deliberate modification, excessive corrosion, damage, fracture or inadequate repair not within a prescribed area which adversely affects braking or steering by severely reducing the strength or continuity of a main load bearing structural member. 1. <ol style="list-style-type: none"> a. Excessive displacement of the body relative to the chassis which might lead to loss of control of the vehicle when driven b. insecurity of the body or its supporting members to the chassis so that it is clear that there would be a danger to other road users. 2. Any deliberate modification, excessive corrosion, damage, cracks or inadequate repair of a load bearing body or chassis member which seriously affects its strength within 30cm of the body mountings. 1. A sharp edge or projection, caused by corrosion or damage, which renders the vehicle dangerous to other road users, including pedestrians. <p style="text-align: right;">Cont'd ↓</p>

6.1 Vehicle Structure, Body and General Items

Information	Method of Inspection	Reason for Rejection
<p>The inspection of engine mountings does not apply to Class 3 vehicles.</p> <p>Engine mountings on front wheel drive vehicles includes mountings bolted to the gearbox that provide essential support for the engine.</p>	<p>D. Engine Mountings</p> <ol style="list-style-type: none"> 1. Check the engine mountings for presence, security and condition. <p>E. Steps and Stairs (Class 5 only)</p> <ol style="list-style-type: none"> 1. Check the passenger entrance and exit step(s) for security and condition. 2. Check that any retractable steps operate correctly. 3. On double deck or split level vehicles, check the presence, security and condition of the stairs. 	<p>Reason for Rejection</p> <ol style="list-style-type: none"> 1. <ol style="list-style-type: none"> a. An engine mounting missing or seriously deteriorated resulting in excessive movement b. an engine mounting bracket: <ul style="list-style-type: none"> • missing • insecure, fractured or damaged to the extent that it is likely to fail. 1. An entrance or exit step or its anti-slip provision: <ul style="list-style-type: none"> • insecure • damaged or deteriorated to the extent that it is likely to be a trip hazard or cause injury. 2. Retractable step not operating correctly. 3. <ol style="list-style-type: none"> a. A stair missing b. a stair or its anti-slip provision: <ul style="list-style-type: none"> • insecure • damaged or deteriorated to the extent that it is likely to be a trip hazard or cause injury.

6.2 Seats and Doors

Information	Method of Inspection	Reason for Rejection
<p>Original Design characteristics and specialised modifications (e.g. to enable wheelchair access) are to be accepted.</p> <p>Every effort should be made to lift folded seats to facilitate their inspection; however, this is not mandatory where it would be unreasonable, such as due to the presence of heavy, fragile or numerous passenger effects or other articles.</p> <p>When checking the driver's seat adjustment it is not necessary to check that the seat can be secured in all possible positions.</p> <p>In the case of electrically adjusted seats, it is not necessary to check that any 'memory position' function is working.</p> <p>The inspection of doors does not apply if no driver's or front passenger's doors were fitted as part of the original design of the vehicle.</p> <p>A lack of door handles because of original design characteristics or specialist modification is not a Reason for Rejection provided the door can be latched securely in the closed position.</p> <p>Reasons for Rejection regarding the opening of doors does not apply to:</p> <ul style="list-style-type: none"> goods vehicles modified for the carriage of high value cargoes such as armoured security vehicles passenger doors if the door aperture has been permanently 'filled' as part of a specialised customisation provided that there are no obvious aperture gaps. 	<p>A. Seats</p> <ol style="list-style-type: none"> Check the driver's and all passengers' seats for security. Check that the backrests of all seats (front and rear) can be secured in their normal upright position. Check that the driver's seat position can be adjusted forwards and backwards and secured in the selected positions. <p>B. Doors</p> <ol style="list-style-type: none"> Open and close the driver's and passenger's doors. Check that: <ol style="list-style-type: none"> each door latches securely in the closed position the driver's and front passenger doors can be opened from both inside and outside the vehicle any other passenger doors can be opened from outside the vehicle. Check door hinges, catches and pillars for presence, security and condition. 	<p>Reason for Rejection</p> <ol style="list-style-type: none"> The security of the driver's or any passenger's seat is significantly reduced. A seat back that cannot be secured in the upright position. The driver's seat fore and aft adjustment mechanism not functioning as intended. <ol style="list-style-type: none"> <ol style="list-style-type: none"> A driver's or any passenger's door does not latch securely in the closed position a driver's or front passenger's door cannot be opened from both inside and outside the vehicle using the relevant control in each case a passenger door cannot be opened from outside the vehicle using the relevant control. A door hinge, catch or pillar missing, insecure or deteriorated to the extent that a door cannot be readily opened or closed.

Method of Inspection	Reason for Rejection
<p>C. Passenger Entrance and Exit Doors (Additional checks for Class 5 only)</p> <ol style="list-style-type: none"> 1. Check passenger compartment entrance and exit doors for damage and deterioration. 2. Check the operation of the emergency and remote controls (if fitted) for any passenger entrance or exit door. 3. Check the operation of any passenger 'door open' warning device (if fitted). <p>D. Emergency Exits (Class 5 only)</p> <ol style="list-style-type: none"> 1. Open and close any emergency exit doors and/or windows. Check that each: <ol style="list-style-type: none"> a. can be opened from both inside and outside the vehicle b. latches securely in the closed position. <p>Note: This inspection does not apply to roof hatches and 'break glass' emergency exits.</p> 2. Check the presence of the hammer in the case of 'break glass' emergency exits. 3. Check the presence and legibility of 'Emergency exit' signs identifying all emergency exit doors and windows. 	<p>Reason for Rejection</p> <ol style="list-style-type: none"> 1. A passenger entrance or exit door damaged or deteriorated so that: <ol style="list-style-type: none"> a. its function is impaired b. it is likely to cause injury. 2. A passenger entrance or exit door emergency or remote control inoperative. 3. A passenger 'door open' warning device inoperative. <ol style="list-style-type: none"> 1. An emergency exit: <ol style="list-style-type: none"> a. cannot be opened from both inside and outside the vehicle from the relevant control in each case b. does not latch securely in the closed position. 2. A missing 'break glass' emergency exit hammer. 3. An emergency exit sign missing or illegible.

6.3 Registration Plates

Information	Method of Inspection	Reason for Rejection
<p>Unregistered vehicles need not be fitted with registration plates.</p> <p>This inspection does not apply to foreign registered, diplomatic or military vehicles.</p> <p>Vehicles manufactured before 1 January 1973 may have registration plates displaying white, grey or silver characters on a black background.</p> <p>Three-dimensional characters are permitted to use grey edging in order to achieve the 3D effect on any age of vehicle.</p> <p>Quadricycles must be fitted with a front number plate.</p> <p>A three-wheeled vehicle with motorcycle derived steering and suspension does not require a front number plate.</p>	<ol style="list-style-type: none">1. Check that there is a registration plate at both the front and the rear of the vehicle, and check each one for security and condition. 2. On vehicles first registered on or after 1 January 1973, check:<ul style="list-style-type: none">• the colour of the characters and background• that the registration plates are fixed vertically, or as close to vertical as is reasonably practical. 3. On vehicles first registered on or after 1 September 2001, check that the registration plates do not display a honeycomb or similar effect background.	<ol style="list-style-type: none">1. A registration plate:<ol style="list-style-type: none">a. missing or incorrectb. so insecure that it is likely to fall offc. letter or figure missing or incompleted. faded, dirty, delaminated, deteriorated or obscured, (for example by a towbar) so that it is likely to be misread or is not easily legible by a person standing approximately 20 metres to the front/rear of the vehiclee. background overprinted or shadowed with text e.g. vehicle manufacturer name. 2.<ol style="list-style-type: none">a. a front registration plate does not have black characters on a white backgroundb. a rear registration plate does not have black characters on a yellow backgroundc. a registration plate not fixed vertically, or as close to vertical as is reasonably practical. 3. A registration plate obviously displaying a honeycomb or similar effect background.

Cont'd ↓

Cont'd ↓

	Method of Inspection	Reason for Rejection
	<p>4. Refer to pages 4 and 5 and check visually that the characters are correctly formed, spaced, and are not obviously likely to be misread due to, for example, badly positioned or uncovered retaining bolts etc.</p>	<p>4. A registration plate with:</p> <ul style="list-style-type: none"> a. characters which are obviously not the correct height, character width, stroke width, not of equal width along their entire length or incorrectly spaced b. a character not correctly formed, sloping, or likely to be misread c. any feature that has the effect of changing the appearance or legibility of any of the characters, so that the true identity of the vehicle is less easily established d. characters formed using a font which is not substantially similar to the prescribed font e. characters formed using broken or multiple strokes f. characters laid out in an incorrect format g. a margin obviously less than the minimum requirement h. a non-reflective border obviously wider than permitted or positioned too close to the characters (see page 5).
	Cont'd ↓	Cont'd ↓

6.3 Vehicle Identification Number

Information	Method of Inspection	Reason for Rejection
<p>A Vehicle Identification Number (VIN or chassis number) is required on all vehicles first used on or after 1 August 1980, except those which are:</p> <ul style="list-style-type: none">• kit cars• amateur built vehicles <p>If a VIN cannot be found the vehicle presenter should be advised of the likely location of the VIN and asked to thoroughly search for the number with the aid of the registration certificate.</p> <p>If following this action the VIN cannot be found, or in circumstances where more than one different VIN is present the vehicle presenter should contact the nearest Vehicle Registration Office.</p>	<p>5. Check that the vehicle is permanently displaying a legible Vehicle Identification Number.</p> <p>This can be either:</p> <ul style="list-style-type: none">• on a VIN plate secured to the vehicle, or• stamped or etched on the vehicle body or chassis.	<p>5.</p> <ul style="list-style-type: none">a. A Vehicle Identification Number not permanently displayed, incomplete or not legible <p>Note: Only one VIN is required to be complete and legible.</p> <ul style="list-style-type: none">b. more than one different Vehicle Identification Number displayed. <p>Note: It is acceptable for a vehicle that has been manufactured as part of a multistage build, (a modification taken place to a vehicle at the manufacture stage before sold as new) to show more than one VIN.</p> <p>The second and subsequent stage VINs will also be a 17 digit VIN and will be displayed on an additional plate. When a multistage built vehicle is presented for test the last stage VIN must be used for MOT documentation.</p>

6.3 Registration Plates – Additional Information

Prescribed Font

**I23456789
ABCDEFGHIJ
KLMNOPQ
RSTUVWXYZ**

Format

New style (from 1 September 2001) registrations must be set out in either a one or two line format as illustrated below.



Cont'd ↓

Vehicles registered before 1 September 2001, can be set out in either one, two or three line formats, as illustrated below.

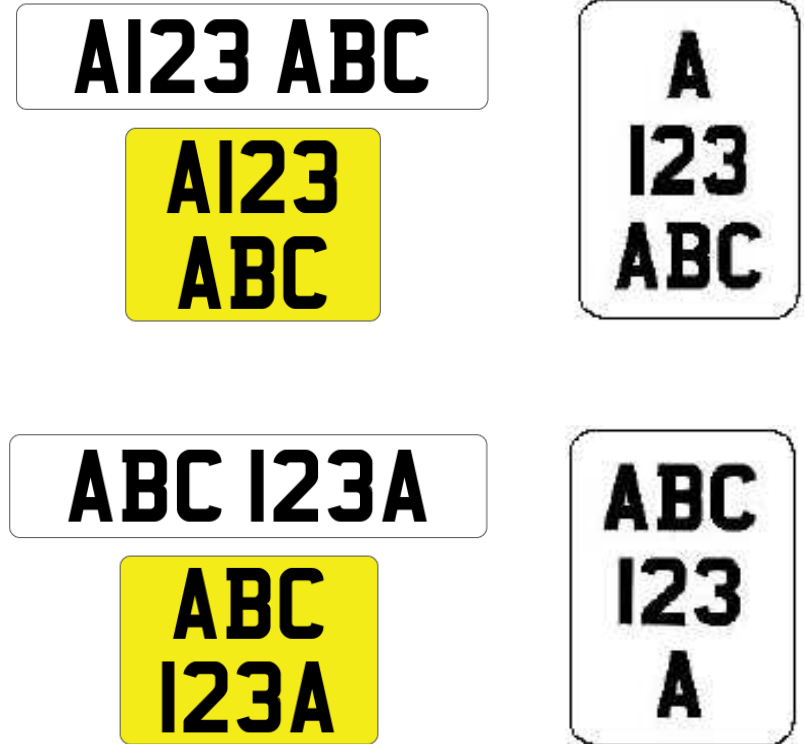

Cont'd ↓

6.3 Registration Plates – Additional Information

Cherished Plates

Older style registrations must meet the registration plate requirements according to the date of first registration of the vehicle, with a format style similar to that illustrated below e.g. letters on one line, figures on another, or a larger space between the two groups of characters.



Northern Ireland Registration Plates

These are not age related and usually consist of three letters followed by four numbers. They must conform to the same standards as other UK registration plates, depending on the date of first registration. This includes the optional display of the distinguishing sign of the UK.

Borders

Registration plates can optionally display a non-reflective border with a maximum width of 6mm and not closer than 5mm to the characters.

Size of Characters

Testers are not required to physically measure the characters or their spacing and the following information is provided for guidance only. Registration plates should only be rejected for character dimensions or spacing if they are clearly incorrect.

Relevant Dimension	Tricycles & quadricycles	All other vehicles
Character height	64mm	79mm
Character width (except for the figure 1 or letter I)	44mm	50mm
Stroke width	10mm	14mm
Space between two characters in group	10mm	11mm
Vertical space between groups of characters	13mm	19mm
Horizontal space between groups of characters	30mm	33mm
Margins (minimum)	11mm	11mm

Larger plates may be fitted to some vehicles registered before 1 September 2001 with characters 89mm high and other relevant dimensions that are subsequently larger.

Imported vehicles whose construction/design cannot accommodate standard size number plates are permitted to display registration plates with smaller characters, in line with those for tricycles and quadricycles detailed in the table. Their margins and vertical space between groups may also be reduced to 5mm.

The space permitted between a “1” or an “I” and another character is proportionately greater than the above dimensions.

6.4 Load Security, Spare Wheel and Carrier

Information	Method of Inspection	Reason for Rejection
<p>Original vehicle design characteristics are to be accepted.</p> <p>Temporary fixings such as rope, cable ties etc. are not acceptable.</p>	<p>Load Security</p> <ol style="list-style-type: none">1. Check that any bootlid, tailgate, loading door, access panel, hinged tailboard or dropside is or can be secured in the closed position. <p>Spare Wheel and Carrier</p> <ol style="list-style-type: none">2. Check that any externally fitted spare wheel and/or carrier is securely attached to the vehicle.	<ol style="list-style-type: none">1. A bootlid, tailgate, loading door, access panel, hinged tailboard or dropside cannot be secured in the closed position.2. An externally fitted spare wheel or carrier insecure to the extent that it is likely to fall off.

6.5 Speed Limiter Plate

Information	Method of Inspection	Reason for Rejection
<p>This inspection applies to all vehicles which are required to be fitted with a Speed Limiter.</p> <p>Vehicles required to be fitted with a speed limiter are:</p> <p>Vehicles with more than 8 passenger seats with:</p> <ul style="list-style-type: none"> • a maximum speed in excess of 100km/h (62.14mph), if a speed limiter were not fitted, and • a DGW not exceeding 7500kg and first used on or after 1 January 2005, or • a DGW exceeding 7500kg and first used on or after 1 January 1988. <p>Vehicles with more than 16 passenger seats:</p> <ul style="list-style-type: none"> • with a maximum speed in excess of 112.65km/h (70mph), if a speed limiter were not fitted, and • with a DGW exceeding 7500kg, and • first used between 1 April 1974 and 31 December 1987. <p>Note: Vehicles with a DGW not exceeding 7500kg with Euro III (or later) engines, first used between 1 October 2001 and 31 December 2004 are required to be fitted with a speed limiter.</p> <p>Specific identification of these vehicles is not required; however, if it is obvious that a speed limiter is fitted then it must meet the requirements of this inspection.</p>	<p>A. Speed Limiter Plate</p> <ol style="list-style-type: none"> 1. Check that a speed limiter plate is securely fixed in the driver's compartment in a conspicuous position. <p>Note: If the plate is fixed to the driver's compartment window it is acceptable for the details to face inwards or outwards, provided that exterior facing plates can be read by a person of average height.</p> 2. Check that the plate is clearly and indelibly marked with the speed at which the speed limiter has been set (the speed may be shown in mph or km/h). <p>Note: The character and composition of the plate and size of lettering are not important provided the details are legible.</p> 	<ol style="list-style-type: none"> 1. A speed limiter plate: <ol style="list-style-type: none"> a. missing or insecure b. not in a conspicuous position. 2. A speed limiter plate: <ol style="list-style-type: none"> a. not clearly and indelibly marked with the set speed b. shows a set speed greater than that permitted (see information column).

6.5 Speed Limiter

Information	Method of Inspection	Reason for Rejection
<p>This inspection is confined to those parts that are readily visible without dismantling.</p> <p>Some vehicles may have been modified by, for example, changing the rear axle ratio and will no longer be capable of exceeding 100km/h. If a vehicle presenter claims that this is the case, he must produce a signed declaration stating the specific reason (e.g. low ratio axle fitted) why the vehicle is no longer capable of 100km/h.</p> <p>Note: Speed limiters wired through 'ignition switches' are acceptable but any other devices that could enable the speed limiter to be switched off while driving are not.</p> <p>Tamperproof devices may also take the form of mechanical and electrical connections that require the use of special tools, normally only available from vehicle/component manufacturers for disconnection or adjustment purposes. These are acceptable instead of the tamperproof devices referred to in Mol 4.</p> <p>Modern tamperproof devices are electronic and therefore not possible to check.</p> <p>A vehicle's DGW should be taken from the manufacturer's plate. For vehicles first used before 1 April 1982 not fitted with a manufacturer's plate, multiply the maximum number of passengers and crew, excluding the driver, by 63.5kg and add the kerb or unladen weight displayed on the side of the vehicle to obtain the calculated laden weight, which should be used instead.</p>	<p>B. Speed limiter</p> <ol style="list-style-type: none"> 1. Check that a speed limiter is fitted and secure. 2. Check any exposed actuating rods/cables for disconnection or damage. 3. Check any visible electrical wiring that energises the speed limiter for disconnection or potential easy disconnection by unauthorised means. 4. Check as far as possible the presence and condition of tamperproof devices such as seals, lock nuts, pins, wires, plastic inserts, sealing compound or sealing paint on mechanical and electrical connections. 	<p>Reason for Rejection</p> <ol style="list-style-type: none"> 1. A speed limiter not fitted or insecure. 2. Actuating rods/cables disconnected or damaged to the extent that the operation of the speed limiter is obviously affected. 3. Electrical wiring is obviously disconnected or can be easily disconnected by unauthorised means. 4. Tamperproof device missing or defective, or showing evidence of obvious disturbance.

6.6 Towbars

Information	Method of Inspection	Reason for Rejection
<p>This inspection applies to: all types of towbar fitted to the rear of a vehicle. It does not include emergency towing eyes.</p> <p>Tow ball covers must not be removed to facilitate inspection of the tow ball.</p> <p>Some tow bars are ‘hidden’ behind an access panel in the bumper or bodywork. Unless requiring the use of tools or specialist equipment, these panels must be removed to facilitate the inspection of towbar components, as well as checking inside the luggage compartment, including lifting of loose fitting mats or carpet.</p> <p>Retractable towbars should be tested in their ‘in-use’ position unless this requires the use of tools or specialist equipment.</p> <p>If a tow ball or pin is not fitted at the time of test, e.g. because it is detachable, has been unbolted or otherwise removed, but the attachment brackets are still in place, these brackets should still be assessed unless they have been deliberately rendered unfit for further use.</p> <p>There may be play in some detachable tow balls between the receiver socket and the tapered swan neck fitting, with up to 3mm movement measured at the ball end. Reason for Rejection 4a should only be used where play is greater than this.</p> <p>Quick release mechanisms must not be operated, only visually assessed.</p> <p style="text-align: right;">Cont’d ↓</p>	<ol style="list-style-type: none"> 1. Visually assess the towbar for wear and pull on the towbar and/or its mountings to check for security, corrosion, fractures or damage. 2. Check the towbar assembly is attached to the vehicle structure using mountings, supports and fixings of an appropriate size and type. 3. Check the presence and security of: <ol style="list-style-type: none"> a. retaining devices e.g. nuts & bolts b. locking devices e.g. split pins, ‘R’ pins. <p>Note: It is not always possible to determine the presence and effectiveness of certain types of locking devices eg locking fluid or ‘nyloc’ nuts.</p> 4. On detachable tow balls: <ol style="list-style-type: none"> a. check for play between the tow ball arm and its receiver socket b. visually assess the condition of any quick release mechanism. <p style="text-align: right;">Cont’d ↓</p>	<ol style="list-style-type: none"> 1. A towbar component insecure, fractured or excessively: <ul style="list-style-type: none"> • worn • corroded, or • damaged. 2. Towbar assembly is attached to the vehicle structure using a mounting, support or fixing which is obviously of an inappropriate size or type. 3. <ol style="list-style-type: none"> a. Retaining device missing or insecure b. locking device missing, insecure, inadequate or damaged to the extent that its operation is impaired. 4. <ol style="list-style-type: none"> a. Excessive play between a detachable tow ball and its receiver socket b. a quick release mechanism that does not secure the tow ball arm as intended. <p style="text-align: right;">Cont’d ↓</p>

6.6 Towbars

Information	Method of Inspection	Reason for Rejection
<p>Wear in a pin, jaw or hook should be regarded as excessive if the thickness of the metal at any point is reduced by more than 25% of the original thickness. Pin locating holes should be rejected if they are worn or elongated by more than 25% of their original diameter. These criteria also apply to pins and brackets for any height adjustment or swivel devices.</p> <p>For tow balls the amount of acceptable wear is considerably less. However, a tow ball should only be rejected if a visual assessment indicates that the tow ball is obviously excessively worn.</p> <p>Many 'bolt-on' type tow balls have accessory devices sandwiched between the tow ball and its mounting flange. These are not to be considered as inappropriate modifications unless their fitment is clearly likely to adversely affect the roadworthiness of the vehicle/trailer combination.</p> <p>Trailer electrical couplings are tested under Section 1.9.</p>	<ol style="list-style-type: none">5. On height adjustable or swivelling towbars, check:<ol style="list-style-type: none">a. for presence, and security of locating or swivel pinsb. locating or swivel pins and brackets for excessive play or wearc. locating or swivel pin retaining devices for presence and security.6. Check the condition of the body and chassis in the vicinity of the towbar mountings.7. Check the towbar assembly for any inappropriate repair or modification.	<ol style="list-style-type: none">5.<ol style="list-style-type: none">a. A locating or swivel pin missing or insecureb. excessive play or wear in a locating or swivel pin or bracketc. a locating or swivel pin retaining device missing or insecure.6. Any deliberate modification, excessive corrosion, damage, fracture or inadequate repair of a load bearing structure or supporting panelling within 30cm of the towbar mountings, which affects its strength to the extent that the security of attachment of the towbar is significantly reduced.7. A towbar assembly inappropriately repaired or modified such that it is likely to adversely affect the roadworthiness of the vehicle/trailer combination.

6.7 Speedometer

Information	Method of Inspection	Reason for Rejection
<p>This inspection applies to all vehicles first used on or after 01 October 1937 other than those in Class 3.</p> <p>If the dial glass is cracked, it is not a Reason for Rejection, providing:</p> <ul style="list-style-type: none">• there is no possibility of misreading the speedometer or• there is no possibility fouling of the indicator needle or• the cracked glass does not create a safety hazard. <p>A Tachograph is an acceptable alternative to a speedometer providing it satisfies the requirements of this inspection.</p>	<ol style="list-style-type: none">1. Check that a speedometer is fitted.2. Check the condition of the speedometer.3. Check that the speedometer can be illuminated.	<ol style="list-style-type: none">1. Speedometer not fitted.2. Speedometer incomplete, clearly inoperative or the dial glass broken or missing.3. The speedometer cannot be illuminated.

Information	Method of Inspection	Reason for Rejection
<p>This inspection applies to Class 5 vehicles only and includes those driving controls that are not covered in other Sections of the Manual, for example; clutch, accelerator, gear selector and engine stop.</p> <p>Vehicles fitted with a smooth clutch pedal pad that from manufacture did not incorporate grooves or the fitting of an anti-slip material should not be subject to failure.</p> <p>The provision of a pedal rubber that is itself an anti-slip material is not regarded as a Reason for Rejection if the design pattern is worn smooth.</p>	<ol style="list-style-type: none"> 1. While sitting in the driver's seat, by operating the driving controls, where appropriate, check that they are: <ol style="list-style-type: none"> a. functionally complete b. not cracked, fractured or excessively corroded c. not obstructed or impeded in their travel d. positioned so that they can be satisfactorily operated without impairing proper control of the vehicle e. secure. <p>Note: Unless certain of the function of a control, the advice of the driver must be sought before it is operated.</p> 2. Check that the driver's area is free from rubbish or other items liable to interfere with the proper control of the vehicle. 3. Check anti-slip provisions on the clutch pedal pad. 4. Check that a means of stopping the engine is provided and functioning. 	<ol style="list-style-type: none"> 1. A driving control: <ol style="list-style-type: none"> a. functionally incomplete b. cracked, fractured or excessively corroded c. obstructed or impeded in its travel d. positioned so it cannot be operated without impairing proper control of the vehicle e. insecure. 2. Presence of rubbish or other items likely to interfere with the proper control of the vehicle. 3. Anti-slip provision on clutch pedal pad missing, loose or worn smooth. 4. A means of stopping the engine not provided or inoperative.

6.9 Glazing

Information	Method of Inspection	Reason for Rejection
<p>This inspection applies to Class 5 vehicles only.</p> <p>Equipment or objects not originally fitted to the vehicle as part of the original design should not obstruct the driver's view.</p> <p>Obstruction to vision can result from any crack, discoloration or opacity in a windscreen or window, an item attached to the glass or on the vehicle or a modification to the vehicle.</p> <p>'Safety glass' means glass which, if fractured, does not fly into fragments likely to cause severe cuts.</p> <p>Safety glass can be identified by evidence of one of the following markings:</p> <ul style="list-style-type: none"> • BS 857 • BS 5282 (not acceptable on vehicles first used on or after 1 April 1985) • TP GS or TP GSE (glass made in France, not acceptable on vehicles first used on or after 1 October 1986) • BS AU 178 • an 'E' mark (including the number 43R) • an 'e' mark followed by a number, e.g. e11, in a square. <p>Marking is not required for safety glass on vehicles first used before 1 June 1978.</p> <p style="text-align: right;">Cont'd ↓</p>	<ol style="list-style-type: none"> 1. Sit in the driver's seat and check that there is a reasonable view of the road through the windscreen and windows wholly or partly on either side of the driver's seat. 2. Check presence and security of all windscreens, side, roof or rear windows, or internal screens or partitions. 3. Visually check the condition of all windscreens, internal screens and partitions, side, rear, roof and door windows for cracks and surface damage. 4. Check for presence, security and condition of guard rails or barriers at windows, internal screens or partitions. 5. On vehicles first used before 1 January 1959, check as far as is practicable, that glass fitted to windscreens and outside windows facing to the front is safety glass. 6. On vehicles first used on or after 1 January 1959, check as far as is practicable, that if glass is used for windscreens or any outside windows it is safety glass. <p style="text-align: right;">Cont'd ↓</p>	<ol style="list-style-type: none"> 1. <ol style="list-style-type: none"> a. The presence of an object which seriously restricts the driver's view of the road ahead, bearing in mind the original design of the vehicle b. any crack, surface damage or discoloration which seriously restricts the driver's view of the road to the front or side. 2. Any windscreen, window, internal screen or partition missing or so insecure that it is likely to fall out in normal use or cause injury to any person on the vehicle. 3. A crack or surface damage in glass or other transparent material that presents a danger to any person on the vehicle. 4. A guard rail or barrier at a window, internal screen or partition missing, insecure or damaged to the extent that injury to passengers is likely. 5. Glass used for a windscreen or an outside window facing to the front is obviously not safety glass. Note: This does not apply to the upper deck of double decked vehicles. 6. Glass used for a windscreen or an outside window is obviously not safety glass. <p style="text-align: right;">Cont'd ↓</p>

6.9 Glazing

Information	Method of Inspection	Reason for Rejection
<p>Safety glazing means material other than glass which is so constructed or treated that if fractured does not fly into fragments likely to cause severe cuts.</p> <p>There is no marking requirement for safety glazing.</p>	<p>7. On vehicles first used on or after 1 June 1978, check that:</p> <ul style="list-style-type: none">a. windscreens and other windows wholly or partly on either side of the driver's seat, are made from safety glass <p>Note: Security vehicles or vehicles being used for police purposes may alternatively be fitted with safety glazing.</p> <ul style="list-style-type: none">b. all other windows are made from safety glass or safety glazing. <p>8. On vehicles first used on or after 1 April 1988, check that any windows forming all or part of a screen, partition or door in the interior of the vehicle are safety glass or safety glazing.</p>	<p>7.</p> <ul style="list-style-type: none">a. The windscreen and/or other windows wholly or partly on either side of the driver's seat are not made from safety glassb. all other windows not made from safety glass or safety glazing. <p>8. A window forming part or all of a screen, partition or door in the interior of the vehicle not made from safety glass or safety glazing.</p>

Exhaust, Fuel and Emissions

Section Contents

Sub-Section	Subject
7.1	Exhaust System
7.2	Fuel System
7.3	Exhaust Emissions-Spark Ignition <ul style="list-style-type: none">A. All VehiclesB. Vehicles First Used on or After 1 August 1975C. Basic Emissions Test (BET)D. Full CAT Test
7.4	Exhaust Emissions-Compression Ignition <ul style="list-style-type: none">A. Vehicles First Used Before 1 August 1979B. Vehicles First Used on or After 1 August 1979

7.1 Exhaust System

Information	Method of Inspection	Reason for Rejection
<p>The overall security of the exhaust system should be assessed; one or more exhaust mountings missing may not be a Reason for Rejection.</p> <p>A durable repair to an exhaust system which effectively prevents leaks is acceptable providing the system is structurally sound.</p> <p>A minor exhaust leak from, for example, a connection joint or a pin hole, is not a Reason for Rejection,</p>	<ol style="list-style-type: none">1. Check the security of the exhaust system.2. With the engine running, check the exhaust system for leaks.3. On petrol engine vehicles that qualify for a full catalyst emissions test, check the presence of the catalytic converter. Note: To ascertain whether a vehicle qualifies for a full catalyst test, use the flow charts in Section 7.3.C disregarding the result of the Basic Emissions Test.4. During all parts of the emissions test relevant for the vehicle, assess subjectively the effectiveness of the silencer in reducing exhaust noise. Note: For vehicles not subject to an emissions test, the engine should be revved to around 2500rpm or approximately half maximum engine speed if this is lower.5. On Class 5 vehicles only, check that the exhaust tailpipe is positioned so it is unlikely that fumes will enter the driver's or passenger area.	<ol style="list-style-type: none">1. An exhaust system not adequately supported.2. A major leak of exhaust gases from any part of the system.3. A catalytic converter missing where one was fitted as standard.4. A silencer in such condition, or of such a type, that the noise emitted from the vehicle is clearly unreasonably above the level expected from a similar vehicle with a standard silencer in average condition.5. An exhaust tailpipe positioned so that fumes are likely to enter the driver's or passenger area.

7.2 Fuel System

Information	Method of Inspection	Reason for Rejection
<p>This inspection applies to all petrol, diesel and gas powered vehicles.</p> <p>It may be necessary to open the luggage compartment to carry out a full inspection of the fuel system.</p> <p>If access cannot be gained to the fuel cap because it is locked and the key is not readily available or because it cannot be opened for some other reason see item 2 of the Introduction to this Manual.</p> <p>On gas powered vehicles, the presence of a leak must be confirmed by the use of a leak detection product conforming to BS EN 14291-2004. Leak detection products must be used in accordance with the manufacturer's instructions.</p>	<ol style="list-style-type: none">1. Check the security of all fuel system components.2. Check fuel pipes and hoses for chafing and damage.3. Check for leaks in the fuel system both with and without the engine running.4. Check fuel tank cap /filler neck sealing device for presence, positive fit and condition of sealing washer and flange.	<ol style="list-style-type: none">1. A fuel system component insecure2. A fuel pipe or hose excessively chafed or damaged.3. A leak in any part of the fuel system.4. A fuel tank cap/filler neck sealing device:<ol style="list-style-type: none">a. missingb. does not fasten/close securely:<ul style="list-style-type: none">• by a positive means, and• such that pressure is not maintained on the sealing arrangementc. sealing washer torn, deteriorated or missing, or a mounting flange/sealing method defective such that the leakage of fuel is possible.

7.3 Exhaust Emissions - Spark Ignition - General

Information

This inspection applies to all spark ignition engine vehicles with four or more wheels, except quadricycles and electric/combustion engine (Hybrid) vehicles.

Contained within this section are flowcharts. Carefully use these flowcharts to accurately establish which type of emission test is applicable to the vehicle being tested.

If an engine has been modified in any way, it still has to meet the exhaust emission requirements according to the age of the vehicle.

A personal import must be tested according to its date of first use. The only exemption to this is if the vehicle owner can present to the tester at time of test a letter from the vehicle manufacturer stating that the particular engine as originally installed could not meet the equivalent British emission standards.

If this is the case, then test to the next lower emission standard.

e.g. A 1995 car first used in Africa has a letter from the engine manufacturer stating that the particular engine (engine number to be stated) cannot meet Catalyst emission limits, then use the pre cat limits of CO 3.5%, HC 1200ppm.

Q plated vehicles are to be treated as being first used before 1 August 1975 for emissions purposes.

Vehicles fitted with a different engine must be tested to the requirements of whichever is older, the engine or the vehicle.

e.g. A 1995 car fitted with a 1991 engine (of whatever make), test to 1991 standards for emission purposes.

Note: The onus is on the vehicle presenter to prove engine age.

The following notes should be used in conjunction with the flowcharts on the following pages:

- (1) Two stroke engines do not require an emissions test unless they are subject to the catalyst test.
- (2) <= less than or equal to
- (3) **Advice on establishing whether the design gross weight of a large car exceeds 2500kg**
 - (i) it may be shown on the manufacturers VIN plate (example shown in Section 3.9)
 - (ii) it may be listed only in Section 2 of the current emissions data book
 - (iii) refer to any readily available data, e.g. handbook or data book
 - (iv) if still unsure, assume it to be over 2500kg DGW.

(4) **Vehicles which have been the subject of specialist conversions**, are to be treated, for emissions purposes, as if they had not been converted.

e.g. a motor caravan or ambulance converted from a goods vehicle is still to be treated as **not being** a “passenger car”; an ambulance converted from a “passenger car” or a “passenger car” with seats added is still to be treated as **being** a “passenger car”.

A vehicle originally built with 6 or more seats, in addition to the driver, which has had seats removed is still to be treated as **not being** a “passenger car”.

(5) **The full title of the Department of Transport Emissions book** is “In-Service Exhaust Emission Standards for Road Vehicles”. The latest edition must be used.

Cont'd ↓

7.3 Exhaust Emissions - Spark Ignition - General

Information	Method of Inspection	Reason for Rejection
<p>The engine must be at its normal idle speed and operating temperature when checking exhaust emissions.</p> <p>Engine speeds and temperature can be assessed either subjectively or by reference to manufacturer's or other reliable data.</p> <p>It is important to ensure that the gas analyser probe is inserted as fully as possible into the exhaust pipe and is secure.</p> <p>Early catalyst equipped vehicles may not require a 'CAT' test. The flowcharts and notes must be carefully followed.</p> <p>To prevent the build up of fumes, the test should be carried out in a well ventilated area.</p> <p>Exhaust extraction systems that connect directly onto the tailpipe must not be used during the emissions test. Remote systems are acceptable, but they must not be placed closer than 250mm to the tailpipe.</p> <p>Note: The availability of an extraction system is not a requirement of authorisation.</p>	<p>A. All vehicles</p> <ol style="list-style-type: none"> 1. Raise the engine speed to around 2500 rpm or half the maximum engine speed if this is lower. <p>Hold this speed steady for 20 seconds to ensure that the inlet and exhaust system is properly purged. Allow the engine to return to idle and the emissions to stabilise:</p> <ol style="list-style-type: none"> a. assess the engine idle speed b. assess the smoke emitted from the tailpipe at idle c. rapidly increase the engine speed to around 2500rpm or half maximum engine speed if this is lower and assess the smoke emitted from the tailpipe. Allow the engine to return to idle. 	<ol style="list-style-type: none"> 1. The engine: <ol style="list-style-type: none"> a. is idling at a speed clearly above its normal idling speed b. emits dense blue or clearly visible black smoke for a continuous period of 5 seconds at idle c. emits excessive dense blue or clearly visible black smoke during acceleration which would obscure the view of other road users. <p>Note: Older vehicles, particularly pre-1960, may emit unavoidable smoke due to their design. Such smoke is not a reason for rejection.</p>

7.3 Exhaust Emissions - Spark Ignition - General

Information

Non-catalyst test

1. The Exhaust Emission Test

A check of exhaust emissions is part of the MOT test for all 4-stroke spark ignition engined vehicles with four or more wheels in Classes 4, 5 and 7.

Two of the exhaust gases are included:

- carbon monoxide (CO)
- hydrocarbons (HC)

Assessment on most vehicles is straightforward, but a number of factors should be borne in mind.

2. Conducting the Test

The test should be conducted with the engine warm. Testing a cold engine could lead to an unjustified failure.

It is important to ensure that any enrichment device is not operating.

The engine should be idling normally during the test and should not be subject to significant electrical loading such as heated seats or heated rear windows.

If an engine will not idle, an assistant may apply light throttle pedal pressure.

To assess that these conditions are met, MOT Testers can either:

- Use their own judgement, or
- Refer to manufacturers or other reliable data.

3. Electric engine cooling fans

Many modern vehicles are fitted with electric engine cooling fans which can cut in during an emission test. The extra load on the alternator reduces the idle speed, which causes the engine management system to react. This gives rise to highly variable readings.

If this happens during a test, wait until the fan switches off and the readings stabilise before continuing.

4. Unstable readings

Some vehicles give unstable readings due, for example, to their carburettor or fuel injection system design. Before failing a vehicle, it is important to establish that a particular limit has been exceeded constantly for a period of 5 seconds.

5. Holed exhaust

A holed exhaust can allow air to be sucked in, causing artificially low readings.

Where a vehicle has an exhaust holed to the extent that MOT failure is warranted, the emissions should be rechecked when the exhaust is repaired even if the vehicle does not leave the testing station in the meantime. Owners should be made aware that any emission readings taken with a leaking exhaust might be incorrect.

Holes not justifying MOT failure do not normally have a significant effect on the constitution of the exhaust gases at the tailpipe and can be ignored.

6. Total gas emitted

The MOT limits prescribed relate to the total exhaust gas being emitted by the vehicle.

If a vehicle has a dual exhaust system, then the emissions from the tailpipes should be averaged. This is done by adding together the readings and dividing by two, e.g.

1st pipe emits 6% CO, 400 ppm HC

2nd pipe emits 4% CO, 500 ppm HC

Average CO reading $\frac{6 + 4}{2} = 5\%$
is:

Average HC reading $\frac{400 + 500}{2} = 450 \text{ ppm}$
is:

A single exhaust system has at least one point in the system where all the exhaust gases from the engine travel through the same pipe, even though the system may split at some point to separate silencers or tailpipes. Only one of these need be checked.

A dual exhaust system has two separate pipes from the engine manifold all the way back to the tailpipes. An exhaust system with a balance tube between separate pipes is still considered a dual exhaust.

Cont'd ↓

7.3 Exhaust Emissions - Spark Ignition - General

7. Multi fuel vehicles

Vehicles which run on more than one fuel (e.g. petrol and LPG) should be tested on the fuel they are running on when presented.

There is a slight difficulty with LPG vehicles: the hydrocarbons emitted are propane rather than hexane. So the HC reading obtained must be divided by the "propane/hexane equivalency factor" (PEF) marked on the gas analyser. For example:

An LPG vehicle gives a reading of 700 ppm.

The PEF marked on the machine is 0.48.

So the actual MOT value is:

$$\frac{700}{0.48} = 1458 \text{ i.e. fail}$$

Some exhaust gas analysers have an automatic facility for doing this.

8. Vehicles which only just pass

Many modern vehicles will normally run well below the MOT limits. Where such a vehicle just passes the MOT test, but the tester knows that it is capable of more efficient operation, the owner should be informed.

Vehicles should normally be tuned to the manufacturer's recommended settings wherever possible, but tuning is **not** part of the MOT test.

9. Vehicles which are incapable of passing

Regulations do not require vehicles to achieve CO or HC readings below the original capability of the engine when new.

A very few vehicles may never have been able to meet the MOT limits.

Where a vehicle owner claims that this is the case, and has sound supporting evidence (e.g. a letter from the vehicle manufacturer), the vehicle should be considered exempt from the CO and HC emission requirements.

If the owner does not have sound supporting evidence, a Test Certificate should be refused.

Catalyst test

1. The exhaust emission test

The catalyst test is part of the MOT test for most spark ignition petrol engined vehicles with four or more wheels first used on and after 1 August 1992.

Carbon monoxide (CO), hydrocarbons (HC) and lambda (λ) are checked at fast idle speed and carbon monoxide (CO) is checked again at idle speed.

The test should be self explanatory using the automated routine on 1996 specification exhaust gas analysers. The following points should be borne in mind.

2. Electric cooling fans and other accessories

If, during the catalyst emission test, the engine cooling fan cuts in or out, this is not a problem and the test should continue as normal.

All other vehicle accessories (e.g. headlamps, air conditioning, heaters) shall be **turned off** during the test.

3. Total gas emitted

This paragraph should be read in conjunction with paragraph 6, non-catalyst test.

If a vehicle, which is subject to the catalyst emissions test, has a dual exhaust system, the test should be performed on both tail pipes and the results averaged. This is done by adding together the results and dividing by two, e.g.

Fast idle test

1st pipe: 0.4% CO, 25ppm HC, $\lambda = 1.01$

2nd pipe: 0.2% CO, 15ppm HC, $\lambda = 1.03$

$$\text{Average CO: } \frac{0.4 + 0.2}{2} = 0.3\%$$

$$\text{Average HC: } \frac{25 + 15}{2} = 20\text{ppm}$$

$$\text{Average } \lambda: \frac{1.01 + 1.03}{2} = 1.02$$

Idle test

1st pipe: 0.45% CO

2nd pipe: 0.35% CO

$$\text{Average CO: } \frac{0.45 + 0.35}{2} = 0.4\%$$

4. Holed exhaust

See paragraph 5 for non-catalyst test.

7.3 Exhaust Emissions - Spark Ignition – non CAT Test

Information	Method of Inspection	Reason for Rejection
<p>An approved exhaust gas analyser will be needed to perform this inspection.</p> <p>It is recommended that the emissions test is carried out as soon as possible after driving the vehicle on the road.</p>	<p>B. Vehicles first used on or after 1 August 1975</p> <ol style="list-style-type: none"> 1. Check that the analyser probe can be inserted into the tailpipe. 2. Use a suitable exhaust gas analyser to determine the proportions of carbon monoxide (CO) and hydrocarbons (HC) in the exhaust gas over a period of at least 5 seconds at idle. <p>Note: Any residual hydrocarbons (i.e. those indicated by the analyser when it is sampling only clean air) should be deducted from the HC reading obtained from the vehicle.</p> <p>Note: If a vehicle meets the CO requirement at its normal idling speed but fails the HC check, re-check the HC level at a high idle speed of 2000rpm. If the HC reading is then 1200ppm or less, the vehicle will meet both the CO and HC requirements.</p> <ul style="list-style-type: none"> ▪ the CO requirement must be met with the engine running at its normal (low) idling speed ▪ do not use a cold start/cold running mechanism to achieve a high idle speed. Instead, apply light pressure to the throttle pedal. <p>HC not applicable to Compressed Natural Gas (CNG) fuelled vehicles.</p> 	<ol style="list-style-type: none"> 1 The emissions cannot be measured because a tailpipe accessory is fitted which prevents insertion of the analyser probe 2 The exhaust gas contains: <ol style="list-style-type: none"> a. a carbon monoxide content exceeding the limit for a continuous period of 5 seconds b. a hydrocarbon content exceeding the limit for a continuous period of 5 seconds.

7.3 Exhaust Emissions - Spark Ignition – non CAT Test

Emission test and limits selection

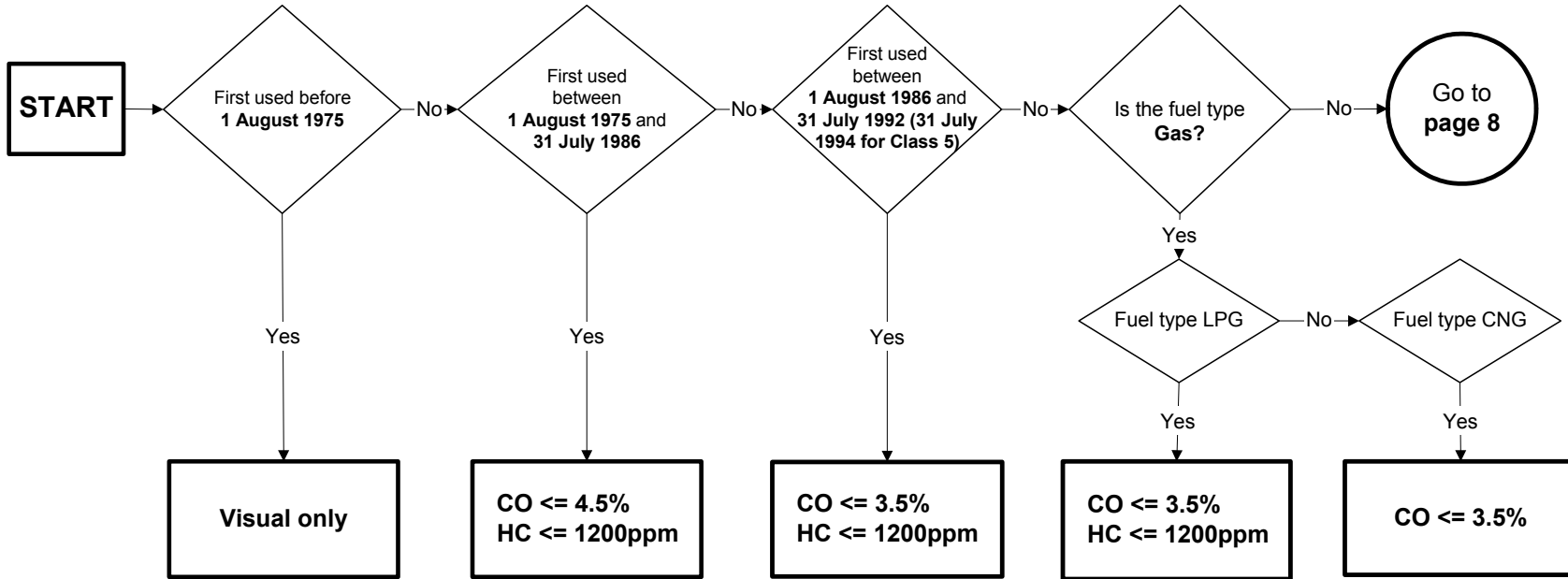

Information: *All Non Catalyst Tests*

This inspection applies to:

All spark ignition engine vehicles with four or more wheels in Class 4, 5 and 7 except quadricycles and electric/combustion engine (Hybrid) vehicles..

1. Use the flowchart to select the correct limits and emission test.
2. When using the flowchart reference should be made to the notes on page 1

For emissions purposes only, kit cars and amateur built vehicles first used before 1 August 1998 and Wankel rotary-engined vehicles first used before 1 August 1987 are to be considered first used before 1 August 1975.

Kit cars and amateur built vehicles first used on or after 1 August 1998 ("S" reg) are required to obtain Single Vehicle Approval and should be tested to the limits stated on the log book / registration certificate.

7.3 Exhaust Emissions - Spark Ignition - BET Test

Information	Method of Inspection	Reason for Rejection
<p>A 1996 specification exhaust gas analyser will be needed to perform this inspection which must have a daily leak check carried out before the first test of each day.</p> <p>The analyser will produce two printouts. One printout must be retained by the VTS for a period of three months. The other printout must be made available to the vehicle presenter.</p> <p>It is important to ensure that the gas analyser probe is inserted as fully as possible into the exhaust pipe and is secure.</p>	<p>C. Basic Emissions Test (BET) Vehicles first used on or after 1 August 1992 – (1 August 1994 for Class 5 vehicles)</p> <ol style="list-style-type: none"> 1. Check that the analyser probe can be inserted into the tailpipe. 2. <ol style="list-style-type: none"> a. Ensure that the engine is hot by checking for example - temperature gauge, cooling fan cut-in or hot coolant hoses. If the engine is not at normal temperature raise the engine speed to between 2000 and 3000rpm and maintain this speed until normal temperature has been reached b. attach engine speed measuring device. It is permissible for the purposes of this check to use the vehicle tachometer c. ensure the engine is idling normally d. perform a HC hang-up check and ensure that HC<20ppm before continuing. Insert the analyser sample probe e. fast idle test: Raise the engine speed to a fast idle between 2500 and 3000rpm and hold steady. Note the readings for CO, HC and lambda, and record the results f. idle test: Allow the engine to idle. Note the CO reading and record the result g. remove analyser sample probe 	<ol style="list-style-type: none"> 1 The emissions cannot be measured because a tailpipe accessory is fitted which prevents insertion of the analyser probe. 2 If the vehicle does not meet the BET limits go to page 9. Note: There is no Reason for Rejection for vehicles that do not meet the BET limits.

Cont'd ↓

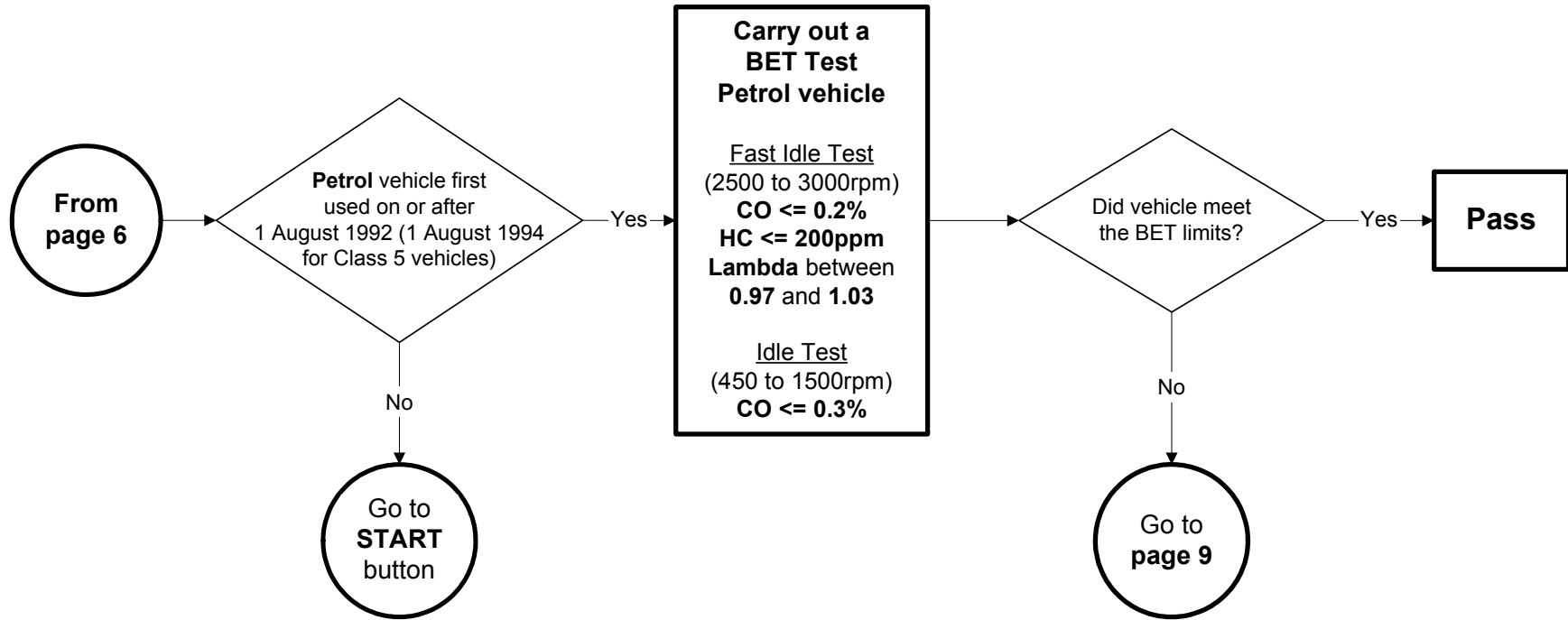

Notes for BET test

1. Ensure that the engine is hot enough to test
eg. temperature gauge, cooling fan cut-in or hot coolant hoses.
2. Ensure that the engine idle speed is normal.
3. For the purposes of this test an engine speed measuring device will normally be required.

7.3

Exhaust Emissions - Spark Ignition - Passenger Cars 1 August 1992 to 31 August 2002

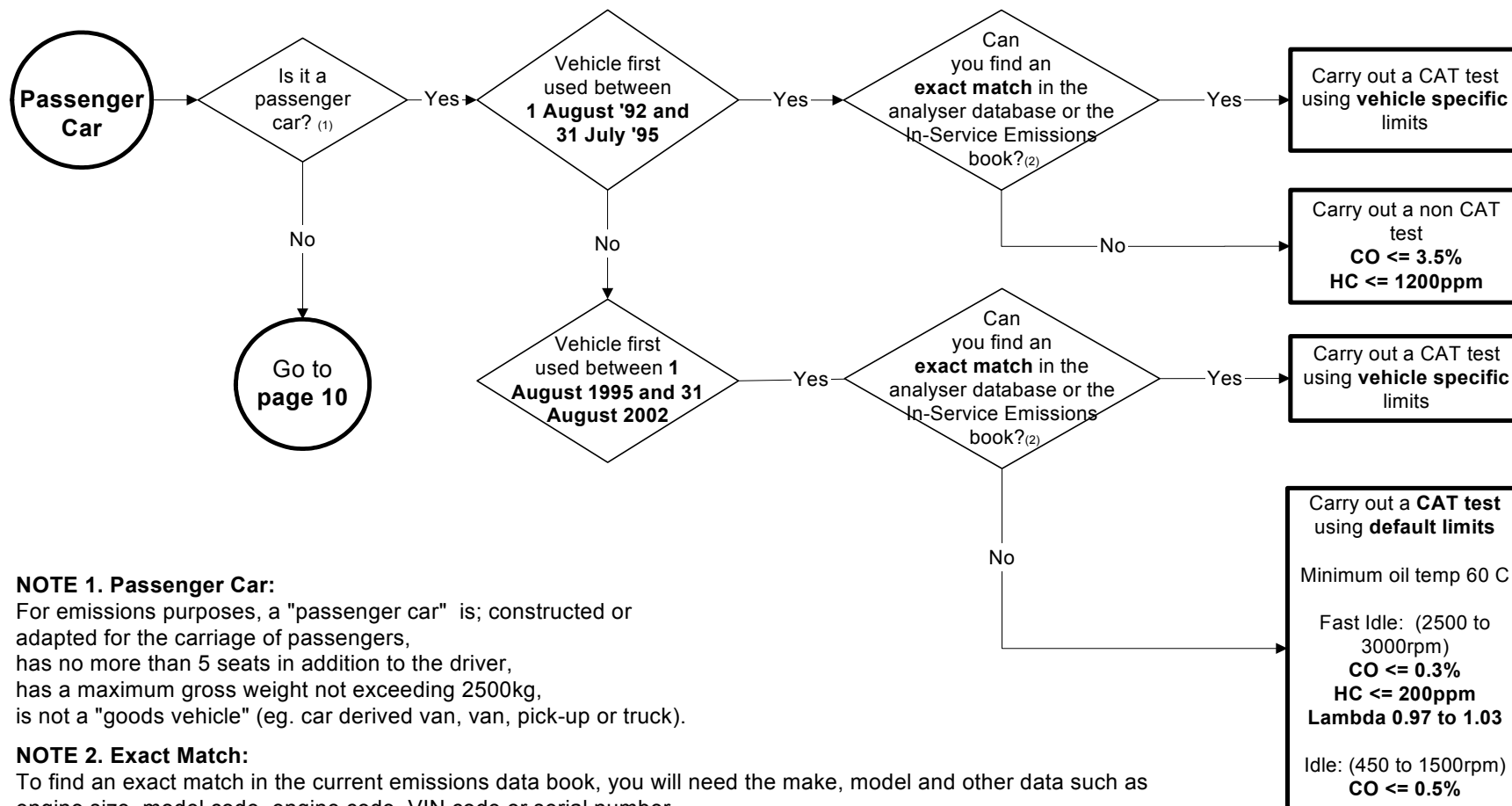

NOTE 1. Passenger Car:

For emissions purposes, a "passenger car" is; constructed or adapted for the carriage of passengers, has no more than 5 seats in addition to the driver, has a maximum gross weight not exceeding 2500kg, is not a "goods vehicle" (eg. car derived van, van, pick-up or truck).

NOTE 2. Exact Match:

To find an exact match in the current emissions data book, you will need the make, model and other data such as engine size, model code, engine code, VIN code or serial number. If after normal cleaning and/or scraping processes a particular code is unreadable or inaccessible, carry on as if no exact match can be found. If the flow chart leads to a non catalyst test then carry out that test. If the flow chart leads to a catalyst test to default limits, then carry out that test, but use the less demanding of either the default limits or the specific limits for any vehicle which is an exact match in everything but an unreadable code.

7.3

Exhaust Emissions - Spark Ignition - Non Passenger Cars 1 August 1992 to 31 August 2002

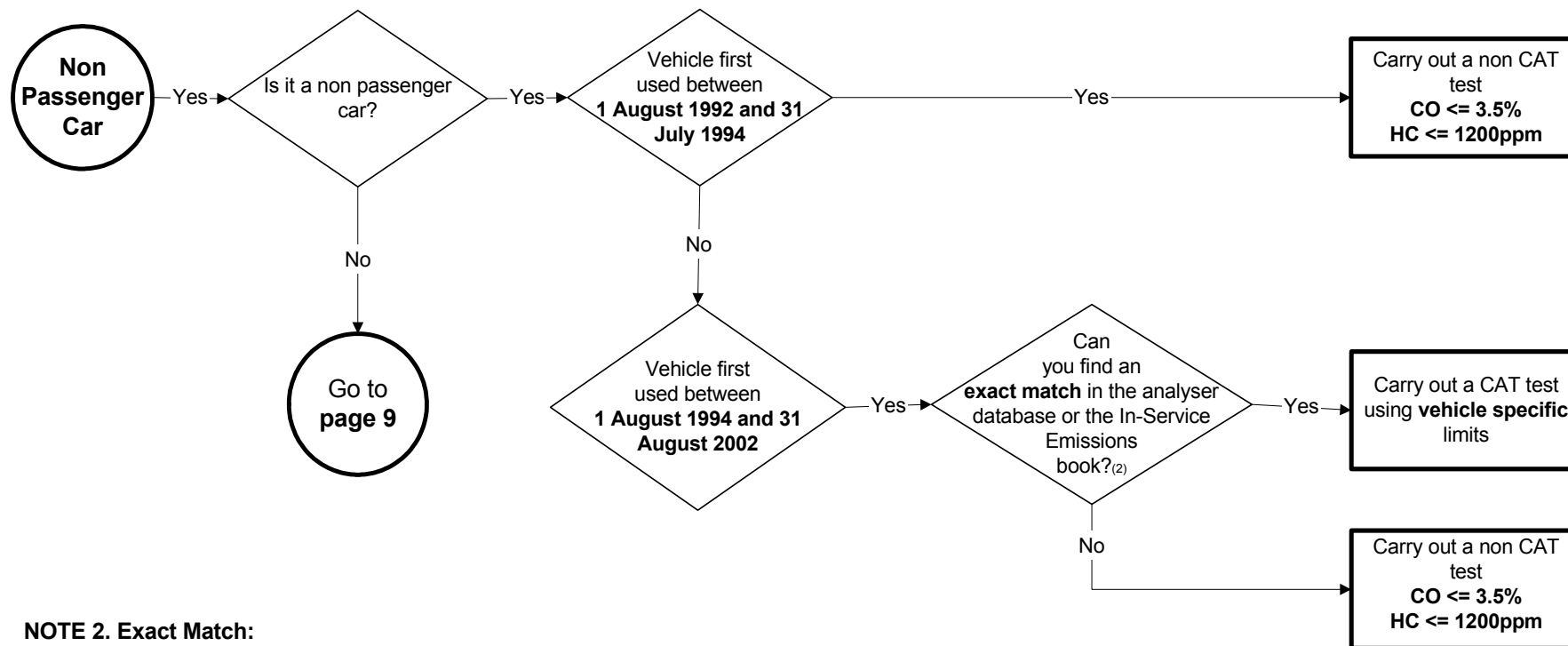

NOTE 2. Exact Match:

To find an exact match in the current emissions data book, you will need the make, model and other data such as engine size, model code, engine code, VIN code or serial number.

If after normal cleaning and/or scraping processes a particular code is unreadable or inaccessible, carry on as if no exact match can be found. Test to default limits, carry out that test, but use the less demanding of either the default limits or the specific limits for any vehicle which is an exact match in everything but an unreadable code.

7.3

Exhaust Emissions - Spark Ignition – All vehicles used on or after 1 September 2002

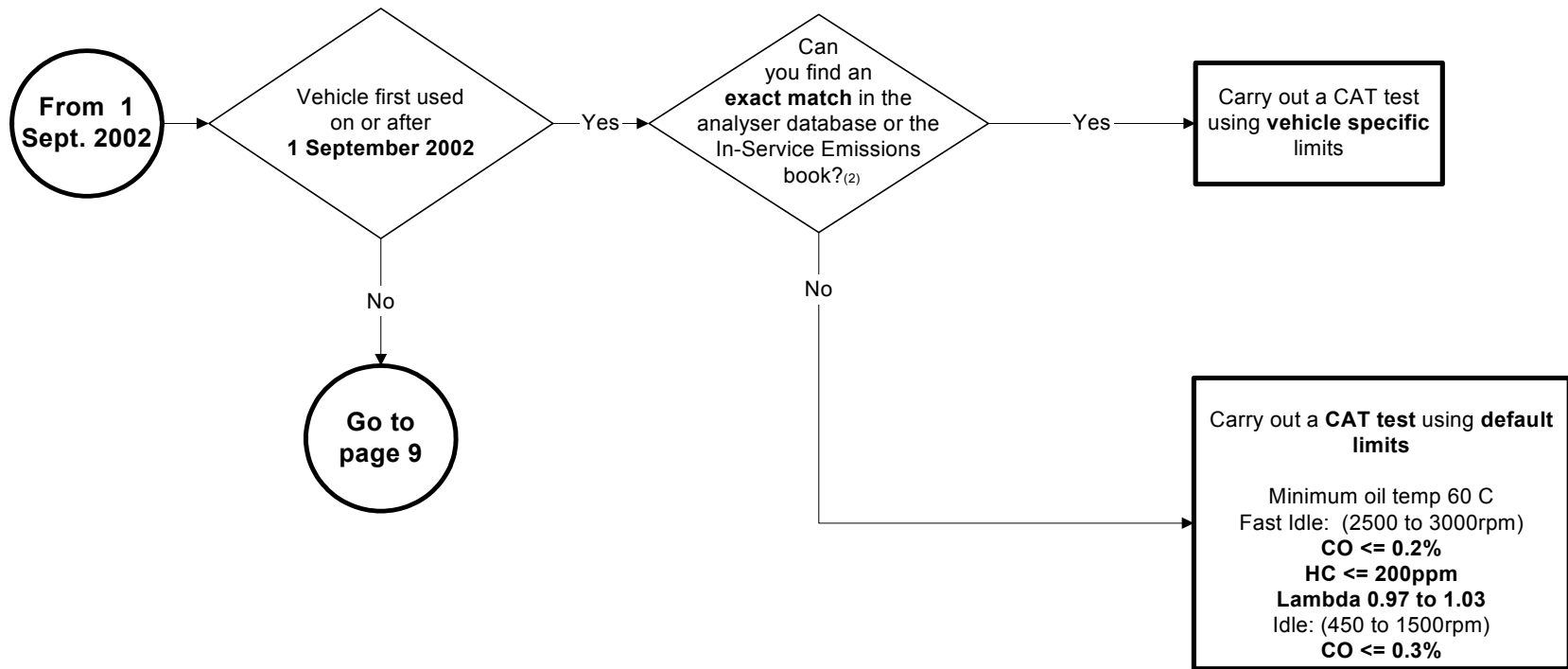

NOTE 2. Exact Match:

To find an exact match in the current emissions data book, you will need the make, model and other data such as engine size, model code, engine code, VIN code or serial number. If after normal cleaning and/or scraping processes a particular code is unreadable or inaccessible, carry on as if no exact match can be found. Test to default limits, carry out that test, but use the less demanding of either the default limits or the specific limits for any vehicle which is an exact match in everything but an unreadable code.

7.3 Exhaust Emissions - Spark Ignition – CAT Test

Information	Method of Inspection	Reason for Rejection
<p>It is recommended that the extended test is carried out as soon as possible after the BET Test. This allows the test to be carried out on a fully warmed up engine.</p> <p>The vehicle specific test limits should be identified using the annex to the current edition of the “In Service Exhaust Emission Standards for Road Vehicles” (stored on the EGA database) and the flow charts on pages 9 – 11.</p> <p>Where engine speed can only be measured by the removal of a cosmetic engine cover, the speed measurement must still be carried out if the cover can be easily un-clipped.</p> <p>If engine speed cannot be measured then the vehicle tachometer should be used if fitted. Otherwise engine speed measurement may be by-passed and a subjective estimate made.</p> <p>Engine oil temperature must be measured whenever possible, using the approved temperature probe. Where, in exceptional circumstances, the engine oil temperature cannot be measured (e.g. in the case of a dry sump engine), check that either:</p> <ul style="list-style-type: none"> the temperature gauge indicated that the engine was at its normal operating temperature the cooling fan had cut in, or the coolant pipes were hot. 	<p>D. Full CAT Test</p> <ol style="list-style-type: none"> Check that the analyser probe can be inserted into the tailpipe. Connect the engine speed measuring device and insert the engine oil temperature measuring probe into the dipstick hole. Check the engine oil temperature. If it is below the minimum vehicle specific requirement, raise the engine speed to between 2000rpm and 3000rpm and maintain this speed until the minimum engine oil temperature has been reached. Remove temperature measuring probe and replace dipstick Perform a HC hang-up check and ensure that HC<20ppm before continuing. Insert the analyser sample probe. Check the engine idle speed. 1st Fast Idle Test: Raise the engine speed to the vehicle specific fast idle speed and maintain for 30 seconds. If the engine speed drifts outside the fast idle speed range, begin the 30 second countdown again. During the last 5 seconds note the readings for CO, HC and lambda, and record the results If the vehicle has passed the first fast idle test, then go to Mol 5, otherwise go to Mol 4. <p style="text-align: right;">Cont'd ↓</p>	<p>Reason for Rejection</p> <ol style="list-style-type: none"> The emissions cannot be measured because a tailpipe accessory is fitted which prevents insertion of the analyser probe. The engine idle speed is clearly above the vehicle specific limit. Note: If the engine speed is clearly above the vehicle specific limit and this can be easily adjusted, a tester may perform the adjustment and complete the test - the adjustment is not, however, part of the MOT test. If the vehicle has failed the first fast idle test, go to Mol 4, otherwise go to Mol 5. <p style="text-align: right;">Cont'd ↓</p>

7.3 Exhaust Emissions - Spark Ignition - CAT Test

Information	Method of Inspection	Reason for Rejection
<p>The analyser will produce two printouts. One printout must be retained by the VTS for a period of three months. The other printout must be made available to the vehicle presenter.</p>	<p>4. 2nd Fast Idle Test: Carry out the following additional engine pre-conditioning:</p> <p>Run the engine between 2000-3000rpm for 3 minutes or until all the emissions are within limits. If the engine speed goes outside the fast idle range, then freeze the countdown until the engine speed is within range once again</p> <p>Then repeat the procedure laid down in Mol 3.</p> <p>5. Idle Test: Carry out catalyst stabilisation by raising the engine speed to the vehicle specific fast idle speed and maintain for 30 seconds. If the engine speed drifts outside the fast idle speed range then begin the 30 second countdown again.</p> <p>Then allow the engine to idle during a 30 second countdown. During the last 5 seconds, note the CO reading and record the result.</p>	<p>4. During the 2nd fast idle test, one or more of the following exceeds the vehicle specific or default limits continuously for the last 5 seconds of the 30 second countdown:</p> <ul style="list-style-type: none">▪ Carbon monoxide (CO)▪ Hydrocarbons (HC)▪ Lambda (λ) <p>5. During the idle test, the level of carbon monoxide (CO) exceeds the vehicle specific or default limit continuously for the last 5 seconds of the 30 second countdown.</p>

7.4 Exhaust Emissions - Compression Ignition

Information	Method of Inspection	Reason for Rejection
<p>This inspection applies to all compression ignition engine vehicles with four or more wheels except quadricycles and electric/combustion engine (Hybrid) vehicles.</p> <p>The smoke test must only be completed when:</p> <ul style="list-style-type: none">• there is sufficient oil in the engine• the oil pressure is not too low• there is no abnormal engine noise• the governor has not been tampered with• the camshaft belt is in a satisfactory condition• the engine is at its normal operating temperature. <p>Note: It is not normally sufficient to run the engine with the vehicle stationary to warm it up to temperature.</p> <p>Engine temperature may be established by, for example, temperature gauge, cooling fan cut-in or hot coolant hoses.</p> <p style="text-align: right;">Cont'd ↓</p>	<p>A. Vehicles first used before 1 August 1979</p> <ol style="list-style-type: none">1. If the engine checks are satisfactory and having removed any oil temperature probe:<ul style="list-style-type: none">• raise the engine speed to around 2500 rpm, or half the maximum engine speed if this is lower• hold this speed steady for 30 seconds to ensure that the inlet and exhaust system is fully purged• allow the engine to return to idle and the emissions to stabilise• assess the smoke emitted from the tailpipe.2. Rapidly increase the engine speed to around 2500rpm or half the maximum engine speed if this is lower and assess the smoke emitted from the tailpipe during acceleration.	<ol style="list-style-type: none">1. The exhaust emits dense blue or clearly visible black smoke for a period of 5 seconds at idle.2. The exhaust emits dense blue or clearly visible black smoke during acceleration which would obscure the view of other road users. <p>Note: The criterion is density and not volume of smoke. The description 'dense smoke' includes smoke or vapour which largely obscures vision.</p> <p>Older vehicles, particularly pre-1960, sometimes emit unavoidable smoke due to their design. Such smoke is not a Reason for Rejection.</p>

7.4 Exhaust Emissions - Compression Ignition

Information	Method of Inspection	Reason for Rejection
<p>An approved diesel smoke meter (DSM) will be needed to perform this inspection.</p> <p>Do not carry out a metered smoke test if the engine is not in a safe condition to do so. This will involve questioning the vehicle presenter and a brief examination of the vehicle condition.</p> <p>The reason for not conducting the test must be clearly shown on the VT30. (See Introduction 2h).</p> <p>Ensure the engine is at least 80 °C or normal operating temperature if lower, before carrying out an instrumented smoke test. This should be achieved by use of an engine oil temperature probe or other approved device.</p> <p>Alternatively, if owing to vehicle configuration, or where this measurement is impractical, the establishment of the engine's normal operating temperature may be made by other means, for example by the operation of the engine cooling fan.</p> <p>The probe on some types of smoke meter must be correctly aligned with the exhaust gas flow. Reference to the smoke meter manufacturer's instructions may be necessary.</p> <p>When testing vehicles fitted with automatic transmission care must be taken to avoid overheating the transmission system.</p> <p>Do not carry out unnecessary engine acceleration or prolonged high revving of the engine. Reference to the vehicle manufacturer's instructions may be necessary.</p> <p style="text-align: right;">Cont'd ↓</p>	<p>B. Vehicles first used on or after 1 August 1979</p> <ol style="list-style-type: none">1. Check that the smoke meter probe can be inserted fully into the tailpipe. <p style="text-align: right;">Cont'd ↓</p>	<ol style="list-style-type: none">1. The emissions cannot be measured because a tailpipe accessory is fitted or a deliberate modification has been made which prevents insertion of the smoke meter probe. <p style="text-align: right;">Cont'd ↓</p>

7.4 Exhaust Emissions - Compression Ignition

Information	Method of Inspection	Reason for Rejection
<p>Maximum engine revs cannot be achieved on some vehicles due to design features. Where this is the case, the vehicle must be tested as presented.</p> <p>The MOT limits prescribed relate to the total smoke level being emitted by the vehicle.</p> <p>If a vehicle has a dual exhaust system, then the smoke test must be repeated and the emissions from the tailpipes averaged. This is done by adding together the readings and dividing by two, e.g.</p> <p>1st pipe emits smoke level of 3.50m⁻¹.</p> <p>2nd pipe emits smoke level of 2.00m⁻¹</p> <p>Average smoke level is: $\frac{3.5 + 2.0}{2} = 2.75\text{m}^{-1}$.</p> <p>A dual exhaust system has two separate pipes from the engine manifold all the way back to the tailpipes. An exhaust system with a balance tube between separate pipes is still considered a dual exhaust.</p> <p>A single exhaust system has at least one point in the system where all the exhaust gases from the engine travel through the same pipe, even though the system may split at some point to separate silencers or tailpipes. Only one of these need be checked.</p>	<p>Fast Pass</p> <p>2. If the engine checks are satisfactory and having removed any oil temperature probe, raise the engine speed to around 2500rpm, or half the maximum engine speed if this is lower, and hold for 30 seconds to fully purge the inlet and exhaust system.</p> <p>Raise engine speed slowly to maximum to check the operation of the governor. Once the engine speed has stabilised or if it becomes clear that the governor is not working, release the pedal, return to idle and stop the engine.</p> <p>Prompt the meter to carry out a zero check.</p> <p>Insert the probe fully and securely, in line with the gas flow. Restart the engine.</p> <p>Following the meter prompts, depress the accelerator pedal quickly and continuously but not violently, to reach full fuel position in less than 1 second.</p> <p>Hold it there until a release prompt is given, then immediately release the pedal. Allow the engine, and any turbocharger fitted, to return to idle speed.</p> <p>At the end of the 1st acceleration read the smoke level displayed on the meter. If it is at or below 1.50m⁻¹ the vehicle has passed this part of the test and a pass result will be displayed on the meter. Go to Method of Inspection 4.</p> <p style="text-align: right;">Cont'd ↓</p>	<p>2. If the vehicle does not meet the fast pass criteria, go to Mol 3.</p> <p>Note: there is no Reason for Rejection for vehicles that do not meet the fast pass criteria.</p> <p style="text-align: right;">Cont'd ↓</p>

7.4 Exhaust Emissions - Compression Ignition

Information	Method of Inspection	Reason for Rejection
<p>Some low emission diesel engines (mainly Euro IV) and those which will not reach maximum revs (due to design features) may fail to trigger a reading due to the very low levels of smoke produced.</p> <p>If the DSM does not register a reading or shows an error, the printout should be marked accordingly showing that the emissions limits were tested and met but the DSM could not register the reading.</p> <p>If the DSM will not produce a printout then the tester must make a written note of the following: -</p> <ul style="list-style-type: none"> • Test Station number • Testers name • Date & time • Test number • Vehicle Type • Vehicle VRN • That the vehicle passed the emissions test • No print out was produced due to low emissions. <p>This information must be recorded and kept with the emissions records for audit purposes for 3 months.</p>	<p>3. If the 1st acceleration smoke level is greater than 1.50m^{-1} carry out two further accelerations following the meter prompts.</p> <p>At the end of the 3rd acceleration, read the mean smoke level displayed on the meter. If it is at or below the appropriate limit, the vehicle has passed this part of the test. Go to Method of Inspection 3.</p> <p>If the mean smoke level is too high, carry out further accelerations up to a maximum of 6 in total.</p> <p>After each acceleration, check the mean reading. This part of the test is complete when either:</p> <ul style="list-style-type: none"> ▪ the mean of any 3 consecutive smoke readings is at or below the appropriate limit, or ▪ six accelerations have been performed. <p>4. Assess whether the smoke emitted from the exhaust, regardless of measure density, is likely to obscure the vision of other road users.</p>	<p>3. After 6 free accelerations, the mean of the last 3 smoke levels is:</p> <ol style="list-style-type: none"> a. for vehicles first used on or after 1 July 2008, more than 1.5m^{-1} for both turbocharged and non-turbocharged engines b. for vehicles first used before 1 July 2008: <ul style="list-style-type: none"> • for a non-turbocharged engine, more than 2.5m^{-1} • for turbocharged engines more than 3.00m^{-1}. <p>4. Exhaust emits excessive smoke or vapour of any colour to an extent likely to obscure the vision of other road users.</p> <p>Note: The criterion is density and not volume of smoke. The description 'dense smoke' includes smoke or vapour which largely obscures vision.</p>

Drivers View of the Road

Section Contents

Sub-Section	Subject
8.1	View to Rear
8.2	Wipers and washers
8.3	Windscreen (Classes 3, 4 & 7 Only)
8.4	Bonnet

8.1 View to Rear

Information	Method of Inspection	Reason for Rejection
<p>This inspection only applies to obligatory rear view mirrors or indirect vision devices.</p> <p>Indirect vision devices (cameras) may replace mirrors on some vehicles, with the view through to the rear displayed on a screen in the driver's cabin. Where such devices are fitted, the Mols and RfRs apply to both the cameras and the screen.</p> <p>There are three acceptable rear view mirror/device positions:</p> <ol style="list-style-type: none"> an exterior mirror or device that provides a view along the offside of the vehicle an exterior mirror or device that provides a view along the nearside of the vehicle an interior mirror or a device which provides a view to the rear of the vehicle. 	<ol style="list-style-type: none"> Check the obligatory mirrors or indirect vision devices for presence and security. Sit in the driver's seat and check that each obligatory mirror or indirect vision device provides an adequate view to the rear. <p>Note: It is not generally necessary to adjust mirrors or devices for this check.</p> 	<ol style="list-style-type: none"> An obligatory mirror or indirect vision device missing or insecure. An obligatory mirror or indirect vision device: <ol style="list-style-type: none"> obscured, damaged or deteriorated so that the view to the rear is seriously impaired does not provide an adequate view to the rear or is incapable of being adjusted to provide an adequate view.

Obligatory Mirror / Device Fitment Requirements

Vehicle Type	Date of First Use	Requirements
Passenger vehicles with less than 8 passenger seats	First used before 1 August 1978	At least one mirror/device in any of the above positions.
Any passenger vehicle (excluding buses and minibuses)	First used on or after 1 August 1978	
Passenger vehicles with 8 or more passenger seats (excluding buses and minibuses)	Any age	Two mirrors/devices, one of which must be in position 'a'.
Goods vehicles		
Buses and minibuses	First used before 1 August 1983	
	First used on or after 1 August 1983	An exterior mirror/device fitted on both the offside and the nearside ('a' and 'b').

8.2 Wipers and Washers

Information	Method of Inspection	Reason for Rejection
<p>This inspection applies to all vehicles, except those with an opening windscreen, or with some other means of providing the driver with an adequate view.</p>	<ol style="list-style-type: none">1. Operate the washers and the wipers and note the swept area of the windscreen. 2. Examine the condition, security and effectiveness of the wiper blades and their contact with the windscreen. 3. Check the function of the windscreen washers.	<ol style="list-style-type: none">1.<ol style="list-style-type: none">a. A wiper or washer control missing or inaccessible to the driverb. a wiper does not continue to operate automatically when switched onc. a wiper installed for the use of the driver does not operate over an area of the windscreen large enough to give the driver an adequate view of the road (through the windscreen) to the left and right sides of the vehicle, as well as to the front. 2. A wiper blade insecure, missing, or in such a condition that it does not clear the windscreen effectively to give the driver an adequate view of the road (through the windscreen) to the left and right sides of the vehicle, as well as to the front. 3. The windscreen washers do not provide enough liquid to clear the windscreen in conjunction with the wiper(s).

8.3 Windscreen

Information

Windscreen Inspection Zones

Zone 'A' is:

- in the swept area of the windscreen
- 290mm wide
- centred on the centre of the steering wheel.

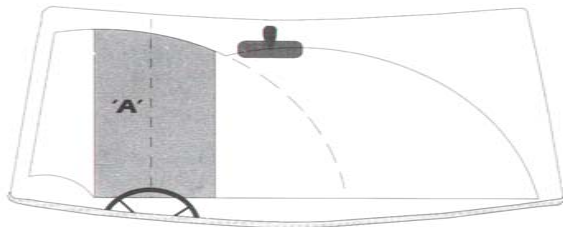

'Official' stickers that are not readily removable, such as vehicle licences, parking and access permits, are only a reason for rejection if they seriously restrict the driver's view. 'Official' stickers should be taken to be any sticker that is used in connection with 'road enforcement', 'security' or 'crime prevention' matters.

These include: Disabled Persons Badges/permits, Parking Permits, Licences and Vehicle Anti-Theft Scheme stickers issued by a Police Authority.

Sunvisors fitted to the driver's side, which cannot be stowed in the 'off screen' position and which drop down obstructing the view through the swept area of the windscreen are a Reason for Rejection. A similar defect on the passenger side sunvisor is not a Reason for Rejection.

Where items are present in the driver's view (such as a sat nav, air freshener etc) that would justify a Reason for Rejection, the tester may, at their discretion, remove the items prior to the inspection. This fact should be noted on an Advisory Notice.

Opaque edging on a windscreen (usually black, particularly at the lower edge) found on some modern vehicles is not to be regarded as part of the windscreen when assessing the drivers view through the windscreen within 8.3 item1 of the Inspection Manual.

Original vehicle design characteristics are to be accepted.

Additional opaque films are subject to Reason for Rejection 1 whether fitted on the inside or outside of the windscreen.

Additional mirrors and tinting films are not subject to Reason for Rejection 1.

Windscreen protection or additional strengthening supports fitted to vehicles which have a security role, e.g. bullion vehicles, Post Office vehicles etc intended to aid security, are not to be considered a Reason for Rejection when assessing obstructions to vision.

Taxi signs displayed in the front windscreen of Hackney Carriage vehicles of the type used to indicate when the vehicle is 'for hire' (usually by being illuminated) are only a Reason for Rejection if they seriously restrict the driver's view.

Mascots and other external mountings forward of the windscreen are not part of the test.

Wiper blades that park automatically in a position that obscures the view through the windscreen are subject to Reason for Rejection 1.

Repaired windscreens must be inspected to the same test criteria as unrepaired windscreens. Repairs must be judged solely on the basis of whether they interfere with vision. An 'invisible' or barely detectable repair, finished flush with the surrounding glass, does not count as damage even if it exceeds the limit on damage allowed in the test.

If these criteria are met, the position and size of repairs is not relevant for the purposes of the test.

Scratches on the windscreen, i.e. light surface scratching, are not to be considered as damage. However, an area of concentrated scratching such as caused by the prolonged use of a defective wiper blade which obscures vision is to be considered a Reason for Rejection if it meets the fail criteria.

Cont'd ↓

8.3 Windscreen

Information	Method of Inspection	Reason for Rejection
<p>This inspection applies to vehicles in Classes 3, 4 & 7 (including those with opening windscreens).</p> <p>Note: For Class 5 vehicles see Section 6.9</p>	<p>1. Whilst sitting in the driver's seat and, referring to the diagram on the previous page, examine the driver's view of the road through the swept area of the windscreen.</p>	<p>1. In Zone 'A':</p> <ul style="list-style-type: none">a. damage not contained within a 10mm diameter circle, orb. a windscreen sticker or other obstruction encroaching more than 10mmc. a combination of minor damage areas which seriously restricts the driver's view <p>In the remainder of the swept area:</p> <ul style="list-style-type: none">d. damage not contained within a 40mm diameter circle, ore. a windscreen sticker or other obstruction encroaching more than 40mmf. a temporary windscreen fitted. <p>Note: All the items listed in the information column should be taken into account before rejecting a vehicle.</p>

8.4 Bonnet

Information	Method of Inspection	Reason for Rejection
<p>This inspection applies to all vehicles with a bonnet which when opened would obscure the drivers view through the windscreen.</p>	<ol style="list-style-type: none">1. Check that the bonnet can be secured in the closed position.2. Check the condition of retaining devices.	<ol style="list-style-type: none">1. A bonnet that cannot be safely secured in the closed position.2. An excessively deteriorated, ineffective or insecure retaining device.

Tricycle and Quadricycle Testing

Section Contents

Sub-Section	Subject
9.1	Lighting Requirements for Tricycles or Quadricycles Classed as Mopeds Requirements for Tricycles and Quadricycles
9.2	Motorcycle Derived Steering / Suspension Systems
9.3	Brakes Brake Controls Brake Performance Requirements
9.4	Tyres
9.5	Seat Belts
9.6	Body, Structure and General Items
9.7	Emissions
9.8	Driver's View of the Road

9.1 Lighting

Information

This Section should be read in conjunction with Section 1 of this Manual.

Tricycles and quadricycles with two service brake controls must operate the stop lamp(s) from both controls.

The Methods of Inspection and Reasons for Rejection are the same as for Section 1 of this Manual. However, the requirements for the fitment of some lamps may be different and they are detailed in the following tables:

Requirements for tricycles or quadricycles classed as mopeds

LAMP	NUMBER	REMARKS
Dipped beam headlamp	1 or 2	If one, it must be mounted centrally, or if adjacent to another lamp (e.g. main beam lamp) they must be mounted symmetrically about the centre. If two, they must be symmetrically mounted.
Front position lamp	1 or 2	If one, it must be mounted centrally, or if adjacent to another front lamp (e.g. a headlamp) they must be mounted symmetrically about the centre. If two, they must be symmetrically mounted. If the maximum vehicle width exceeds 1300mm, two front position lamps are required.
Rear position lamp	1 or 2	If one, it must be mounted centrally. If two, they must be symmetrically mounted. If the maximum vehicle width exceeds 1300mm, two rear position lamps are required.
Stop lamps	1 or 2	If one, it must be mounted centrally. If two, they must be symmetrically mounted. If the maximum vehicle width exceeds 1300mm, two stop lamps are required.
Direction indicators	2 front 2 rear	Only required on 'bodied' 3 wheel mopeds A telltale must be fitted.
Rear reflector	1 or 2	If one, it must be mounted centrally. If the maximum vehicle width exceeds 1000mm, two reflectors are required.

Cont'd ↓

9.1 Lighting

Information

Hazard warning lamps must work both with the engine running and switched off. This may be by use of an engine kill switch or by turning the ignition off.

Requirements for tricycles and quadricycles

LAMP	NUMBER	REMARKS
Main beam headlamp	1 or 2	If one, it must be mounted centrally, or if adjacent to another lamp (e.g. dipped beam lamp) they must be mounted symmetrically about the centre. If the maximum vehicle width exceeds 1300mm, two main beam headlamps are required (1700mm for motorcycle derived tricycles)
Dipped beam headlamp	1 or 2	If one, it must be mounted centrally, or if adjacent to another lamp (e.g. main beam lamp) they must be mounted symmetrically about the centre. If the maximum vehicle width exceeds 1300mm, two dipped beam headlamps are required (1700mm for motorcycle derived tricycles)
Front position lamp	1 or 2	If one, it must be mounted centrally, or if adjacent to another front lamp (e.g. a headlamp) they must be mounted symmetrically about the centre. If the maximum vehicle width exceeds 1300mm, two front position lamps are required.
Rear position lamp	1 or 2	If one, it must be mounted centrally. If the maximum vehicle width exceeds 1300mm, two rear position lamps are required.
Stop lamps	1 or 2	If one, it must be mounted centrally. If the maximum vehicle width exceeds 1300mm, two stop lamps are required.
Direction indicators	2 front 2 rear	A telltale must be fitted.
Hazard warning lamps	2 front 2 rear	A telltale must be fitted.
Rear reflector	1 or 2	If one, it must be mounted centrally. If the maximum vehicle width exceeds 1000mm, two reflectors are required.
Registration plate lamp	1	May be combined with the rear position lamp.

9.2

Motorcycle Derived Steering / Suspension Systems

Information	Method of Inspection	Reason for Rejection
<p>This Section should be read in conjunction with Section 2 of this Manual.</p> <p style="text-align: right;">Cont'd ↓</p>	<ol style="list-style-type: none">1. Examine the handlebars and fork yokes. 2. Turn the steering from lock to lock with the steered wheel both on a turning plate and clear of the ground. 3. Examine the steering damper. 4. Examine the steering head bearings. <p style="text-align: right;">Cont'd ↓</p>	<ol style="list-style-type: none">1.<ol style="list-style-type: none">a. Handgrips missing or not secure to handlebarsb. handlebar flexible mounting excessively deterioratedc. a handlebar or fork yoke:<ul style="list-style-type: none">• excessively deformed• cracked or fractured• excessively corroded• clamps not tight, or any bolt loose or missing• inappropriately repaired or modified. 2.<ol style="list-style-type: none">a. Any fouling or restriction of the free movement of the steering from lock to lockb. handlebar grip/s or handlebar mounted control/s have no clearance with any other part of the machine when the steering is placed on either full lock. 3. A steering damper:<ol style="list-style-type: none">a. insecureb. ineffectivec. impairing the steering action. 4. Excessive free play in the steering head bearings. <p style="text-align: right;">Cont'd ↓</p>

9.2

Motorcycle Derived Steering / Suspension Systems

Information	Method of Inspection	Reason for Rejection
<p>Reason for Rejection 5 does not apply to fork gaiters or shrouds.</p> <p>Light misting of a suspension damper is not a reason for rejection.</p>	<p>5. Examine the front suspension assembly.</p> <p>6. Examine the suspension springs.</p> <p>7. Examine the suspension dampers.</p> <p style="text-align: right;">Cont'd ↓</p>	<p>5. A front suspension assembly component:</p> <ul style="list-style-type: none">a. missingb. loosec. crackedd. excessively bent, misaligned, corroded, worn, or has excessive free play between the sliding members of the forks, the pivot bearings or bushese. restricted in operationf. fouling. <p>6. A suspension spring:</p> <ul style="list-style-type: none">a. incompleteb. crackedc. fracturedd. excessively worn or corroded such that its cross sectional area is reduced to the extent that it is seriously weakenede. repaired by welding. <p>7. A suspension damper:</p> <ul style="list-style-type: none">a. insecureb. leakingc. foulingd. with inadequate damping effect. <p style="text-align: right;">Cont'd ↓</p>

9.3 Brakes

Information	Method of Inspection	Reason for Rejection
<p>This Section should be read in conjunction with Section 3 of this Manual.</p> <p>If an antilock braking system is fitted, it must be tested as described in Section 3.4 of this Manual, with the exception of the sequence of operation.</p> <p>A type of parking brake may be fitted to some type approved machines which does not fully meet the requirements at Section 3.1. These include:</p> <ul style="list-style-type: none"> • a handlebar mounted over-centre lever • a gear lever which, when moved into the park position, operates a cable via a linkage attached to the lever • a transmission lock by selecting the 'P' position on machines with CVT transmission. <p>Testers should not fail these parking brakes under Section 3.1 RfR 6a (when knocked, the lever is not held in the 'on' position), or RfR 6b (when the brake is fully applied there is no possibility of further travel).</p> <p>Additionally, parking brakes that use the 'P' position on the gearbox are not suitable for dynamic efficiency testing. The tester must therefore make the best assessment possible. This could include parking on a gradient (ideally 16%), or if no suitable gradient is available, by attempting to push the machine when 'P' is selected.</p> <p>The over-centre lever type can be brake tested as normal using one of the approved test methods.</p> <p style="text-align: right;">Cont'd ↓</p>	<p>1. Check the service brake controls and mountings.</p> <p>Note: This Method of Inspection is specific to vehicles with hand operated service brake controls. Foot controls should be inspected in accordance with Section 3.3.</p>	<p>1. A service brake control:</p> <ol style="list-style-type: none"> a. missing b. or mounting insecure c. or mounting retaining or locking device missing or insecure <p>Note: It is not always possible to determine the presence and effectiveness of certain types of locking devices e.g. locking fluid or 'nyloc' nuts.</p> <ol style="list-style-type: none"> d. or mounting cracked or fractured e. lever pivot excessively tight or worn f. has inadequate reserve lever travel g. inoperative or so damaged, positioned, bent or shortened that the brake cannot be readily applied h. which cannot be applied and released smoothly i. or mounting excessively corroded j. or mounting inappropriately repaired or modified.

9.3 Brakes

Information

Where a linked system is operated by one control, the retarding force used in the efficiency calculation is the total from all wheels when operated by that control only.

When roller brake testing vehicles of an unknown brake weight, use the locked wheel criteria explained in the notes in Section 3.7, page 4. If the vehicle does not meet this standard then a further brake test using a decelerometer may be conducted in order to assess the brake efficiency **only where it is safe to do so**.

If it is not safe, then the presenter should be asked to provide evidence of the unladen weight of the vehicle and the efficiencies should be calculated using the unladen weight plus 140kg (300lbs).

For the method of calculating brake performance see Section 3.8.

Brake Performance Requirements

A quadricycle with a single service brake control that operates the brakes on all wheels

Service Brake	Parking Brake	
50%	25% if a single line system	16% if a split (dual) system

A tricycle with a single service brake control that operates the brakes on all wheels first used on or after 1 January 1968

Service Brake	Parking Brake	
50%	25% if a single line system	16% if a split (dual) system

A tricycle with a single service brake control that operates the brakes on all wheels first used before 1 January 1968

Service Brake	Parking Brake	
40%	25% if a single line system	16% if a split (dual) system

A three wheeled moped or light quadricycle with a single service brake control that operates the brakes on all wheels

Service Brake	Parking Brake	
40%	25% if a single line system	16% if a split (dual) system

Any tricycle, three wheeled moped, quadricycle or light quadricycle with two service brake systems each having a separate means of operation

Service Brake	Parking Brake	
30% from either system	25% from the other system	16%

9.4 Tyres

Information

This Section should be read in conjunction with Section 4 of this Manual.

The table below gives the minimum tread depth requirements for specified tricycles and quadricycles. Reference should also be made to Section 4.1.D of this Manual.

VEHICLE TYPE	MINIMUM TREAD DEPTH
All quadricycles	1.6mm
Tricycles with an unladen weight exceeding 410kg	1.6mm
Tricycles with an unladen weight not exceeding 410kg and an engine capacity greater than 50cc	1.0mm
Tricycles with an unladen weight not exceeding 410kg and an engine capacity not greater than 50cc	Tread pattern is clearly visible around the entire circumference and across the whole breadth of the tread

Information

This Section should be read in conjunction with Section 5 of this Manual.

The seat belt inspection applies to all tricycles and quadricycles except:

- 3 wheeled mopeds and quadricycles having an unladen weight of not more than 250kg
- tip up occasional seats fitted to any vehicle
- a sit astride, saddle type drivers seat on an unbodied tricycle or quadricycle, or any sit astride, saddle type passenger seat that is immediately in front or behind the driver in a longitudinal plane.
- some unbodied vehicles may have been Type Approved without seat belts. These are acceptable, provided there is evidence that they have been Type Approved to 92/61/EEC or 2002/24/EC. This information will normally appear on the manufacturer's plate.

The requirements for tricycles first used before 17 June 1999 are covered by Section 5 of this Manual.

Note: Additional seats to the side of and non sit astride seats directly behind the driver/passenger are required to be fitted with a minimum of a lap belt.

Requirements

Table of minimum seat belt requirements for tricycles and quadricycles first used on or after 17 June 1999

Drivers seat	Outboard (front) passenger seat	Centre front seat	Forward facing rear seats *
3 point lap and diagonal belt (may be static or inertia), harness belt or disabled persons belt.	3-point lap and diagonal belt (may be static or inertia), harness belt or disabled persons belt.	a lap belt, 3 point lap and diagonal belt (may be static or inertia), harness belt or disabled persons belt	a lap belt, 3 point lap and diagonal belt (may be static or inertia), harness belt, disabled persons belt or child restraint.

* Includes outboard forward facing seats fitted to un-bodied tricycles.

9.6 Body and Structure

Information	Method of Inspection	Reason for Rejection
<p>This Section should be read in conjunction with Section 6 of this Manual.</p> <p>This inspection only applies to vehicles designed or modified to have footrests for the driver and/or passengers. These must only be inspected where it is clear that they are required for the safe operation of the vehicle.</p>	<ol style="list-style-type: none">1. Check driver and passenger footrests for presence and security	<ol style="list-style-type: none">1. A missing or insecure footrest

9.7 Emissions

Information

This Section should be read in conjunction with Section 7 of this Manual.

All tricycles and quadricycles are exempt from emissions testing.

9.8 Drivers View of the Road

Information

This Section should be read in conjunction with Section 8 of this Manual.

Obligatory mirrors/devices are as follows:

- Bodied vehicles must have two mirrors/devices, one of which must be fitted to the offside.
- Unbodied vehicles other than mopeds must have one offside and one nearside rear view mirror/device.
- Unbodied vehicles classed as mopeds must have one mirror/device. If first used on or after 1 August 1978 it must be fitted to the offside.

Windscreen wipers and washers are not required to be fitted on unbodied tricycles or quadricycles fitted with a motorcycle style windshield.

Motorcycle style windshields fitted to unbodied tricycles and quadricycles are not to be considered as windscreens and are therefore not subject to the inspection detailed in Section 8.3 of this Manual.

Appendix A – Reserved for Future Use

Reserved for Future Use

Appendix B – Reserved for Future Use

Reserved for Future Use

Appendix C – Structural Integrity and Corrosion

1. Introduction

The effect of corrosion on the safety of a vehicle depends on the extent of the corrosion and the function of the section or component on which the corrosion has occurred.

A small amount of corrosion in an important part of a vehicle structure can make a vehicle unsafe where it compromises the load bearing capacity of the structure. On the other hand, excessive corrosion on non structural sections may have little or no effect on the vehicle's safety.

Corrosion of a particular part, such as a door sill, may be very important on one type of vehicle construction, but of less importance on another. This can be seen in figures 1 to 4 at the end of this Appendix, where the shaded portions indicate the important load bearing parts of various typical vehicle constructions.

2. Prescribed areas

Certain areas of the vehicle structure are particularly important for the safety of a vehicle. Particular attention must be paid to these areas during an inspection.

These areas are:

- the load bearing parts of the vehicle to which the testable items defined in Sections 2, 3 and 5 of the Inspection Manual are mounted, and
- any load bearing or supporting structure or supporting panelling within 30cm of the mounting location.

To give an example; during the examination of a seat belt mounting on an inner sill, consideration must be given to the outer sill (or the sill reinforcement if the outer sill is a plastic cover), door pillar, floor panel or any other structural part within 30cm of the component's mounting point. It is accepted that it is not possible to assess some of these areas due to the fitment of body trim etc.

3. Corrosion assessment

Having identified the important load bearing members and 'prescribed areas' on a vehicle, the tester should determine whether they are excessively corroded, firstly by visual inspection and then by finger and thumb pressure.

If necessary, the Corrosion Assessment Tool should be used to assess the extent of any corrosion by careful scraping or light tapping of the affected areas.

It is important that use of the Corrosion Assessment Tool is restricted to ascertaining that the failure criteria are met and not used for heavy scraping or poking of the affected areas.

Excessively corroded metal, or metal treated with filler, emits a duller sound than unaffected metal. It is not permissible to apply heavy impact blows or to use a sharp instrument to probe at the structure.

4. Failure criteria within 'prescribed areas'

Corrosion within a 'prescribed area' should be rejected if:

- the corrosion has caused a hole in the metal, or
- it is weakened to the extent that by finger and thumb pressure it does not feel sound, or
- finger and thumb pressure or use of the Corrosion Assessment Tool causes a hole.

Additionally, any fracture or inadequate repair (see items 11 to 14) within a 'prescribed area' is a Reason for Rejection. However, deliberate modification or severe distortion within a 'prescribed area' should only be rejected if the strength of a component mounting, load bearing member, supporting structure or supporting panelling is significantly reduced.

Cont'd ↓

Appendix C – Structural Integrity and Corrosion

5. Failure criteria not within prescribed areas

Structural fractures, damage or corrosion not within the 'prescribed areas' are dealt with in Section 6 of the Manual. The diagrams at figures 1 to 4 show the main load bearing members of various types of vehicle construction which need to be considered.

6. Highly stressed components

The severity of general or local corrosion in highly stressed components, such as steering and suspension arms, rods, levers etc. can be assessed by lightly tapping or scraping with the Corrosion Assessment Tool.

In places inaccessible to the Corrosion Assessment Tool, an alternative blunt instrument may be used. A highly stressed component should be rejected if corrosion has resulted in serious reduction in the overall thickness of the material, or has caused a hole or split.

Welded repairs to highly stressed components such as steering/suspension arms, rods, levers etc are not normally acceptable, other than where the component is made up of sections that are welded together. In these cases the repair should appear to be as strong as the original design.

7. Thin gauge steel pressings

It is common to use thin gauge pressings for certain steering and suspension components, mountings, sub-frames and cross members. These are designed to have minimal material usage with maximum strength, resulting in hollow or open sections or 'up facing' areas in which road dirt impregnated with salt or other chemicals collects causing serious but often very localised corrosion.

These types of components require extra vigilance as there may be little evidence of corrosion on initial inspection, but may reveal severe material failure when looked at more closely.

8. Vehicles with separate bodies

Some vehicle types have bodies and various mechanical components attached to a separate under frame. The frame is the main load bearing structure with a passenger cell and possibly a separate load bed secured on top of the frame, which may also be load bearing or supportive.

Excessive corrosion within these body panels should only lead to rejection if the failure criteria are met for:

- prescribed areas, or
- is likely to adversely affect the correct functioning of the braking or steering, or
- body security.

9. General guidance

The presenter should be advised of any corrosion or damage which has not yet reached the stage where it meets the criteria for rejection. However, it may be necessary to refuse to test the vehicle if excessive damage or corrosion could result in injury or further damage to the vehicle and/or testing facility.

10. Acceptable methods of repair

It is essential that repairs to corroded or damaged areas are properly carried out. This requires that suitable materials of appropriate gauge or thickness are used for repairs. Additionally:

- any plating or welding extends to a sound part of a load bearing member
- the repair must appear to be virtually as strong as the original structure with only continuous seam welding being acceptable for patch repairs (even if the patch extends beyond the prescribed area).

Cont'd ↓

Appendix C – Structural Integrity and Corrosion

- spot welded joints are acceptable where the original panel has been replaced to an existing spot welded flange (provided the original defective panel flange has been removed). Stitch or plug welding is acceptable as an alternative to spot welding in these cases.
- MIG brazing, a combination of adhesive bonding and riveting, or amalgamations of these with other joining methods may be the vehicle manufacturers recommended method of repair. Such repairs must therefore be accepted unless they are clearly inadequate.

11. Unacceptable methods of repair

Gas brazing, soldering, adhesive bonding, fibre reinforcement and body filler are bonding processes and are not regarded as strong enough for repairs to load bearing members although they are normally adequate for other repair work.

It is accepted that it is sometimes difficult to identify the repair method after the repair has been covered in paint or underseal. If the method of repair is in doubt the tester should pass and advise.

12. Testable items mounted to plastic structures

Testable items, such as steering racks, sub frames and seat belts, are sometimes mounted directly to plastic structures that do not have metal reinforcement.

Non-metallic structures must be assessed on their merits. Evidence of weakness such as cracks, separation or delamination within a 'prescribed area' or a component flexing on its mounting to the extent that it is clear that it is likely to work loose or break away are reasons for rejection.

13. Repairs to non-metallic load-bearing structures

Repairs to non-metallic structures are not acceptable within prescribed areas. Any repairs outside of these areas should be as strong as the original structure.

14. Panel removal or replacement with different materials

On a vehicle of integral construction the strength and stiffness of the whole structure may be seriously affected by any panel being removed or replaced by a panel of different material.

If it is considered that a modification has significantly reduced the original strength and stiffness of the structure, the tester should fail the vehicle under the appropriate section. If there is doubt about the effect of the modification the tester should pass and advise.

It is unacceptable for plastics to replace or reinforce corroded or weak metal in prescribed areas and load bearing sections.

Appendix C – Structural Integrity and Corrosion

Figure 1

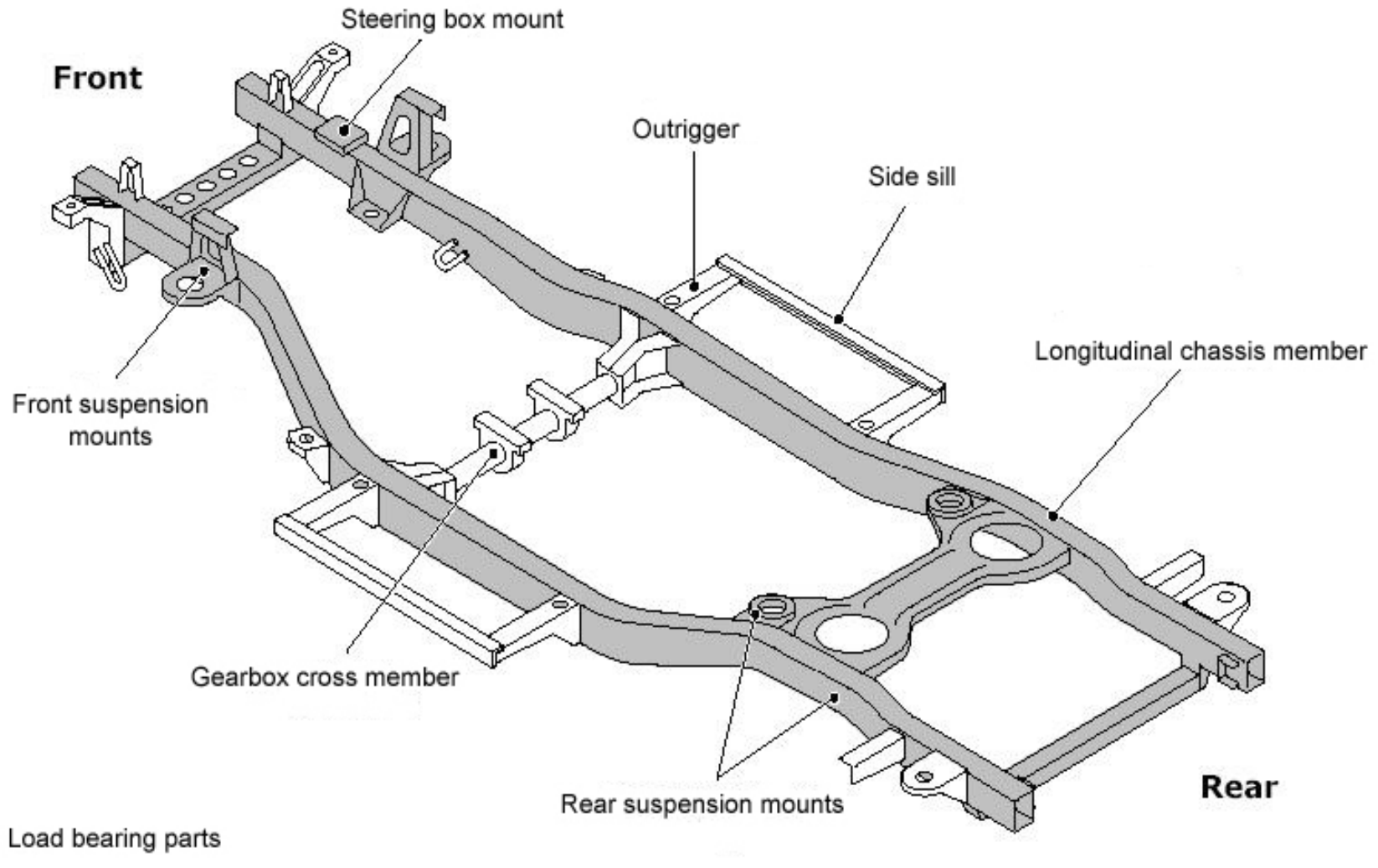

Appendix C – Structural Integrity and Corrosion

Figure 2

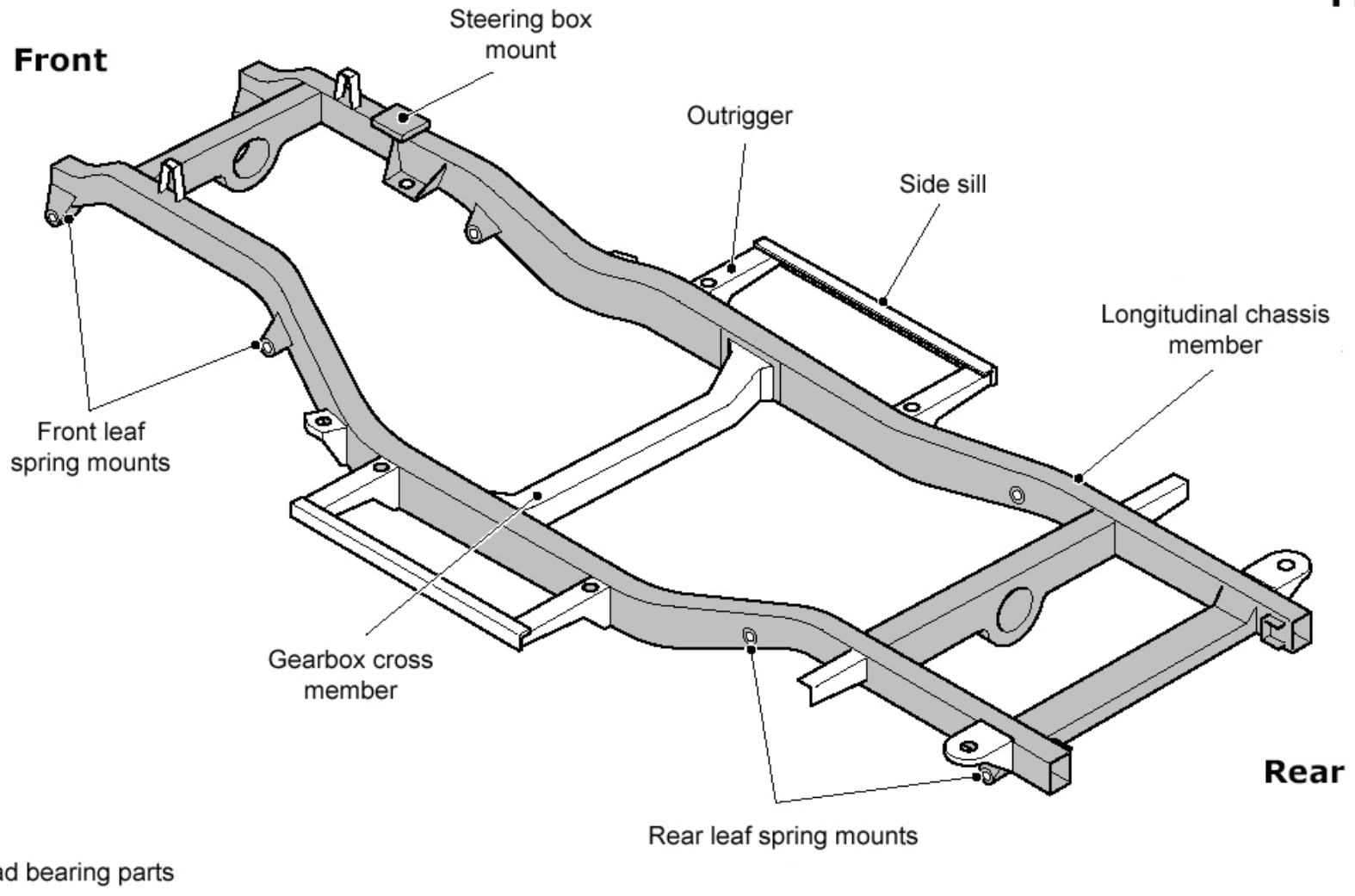

Appendix C – Structural Integrity and Corrosion

Figure 3

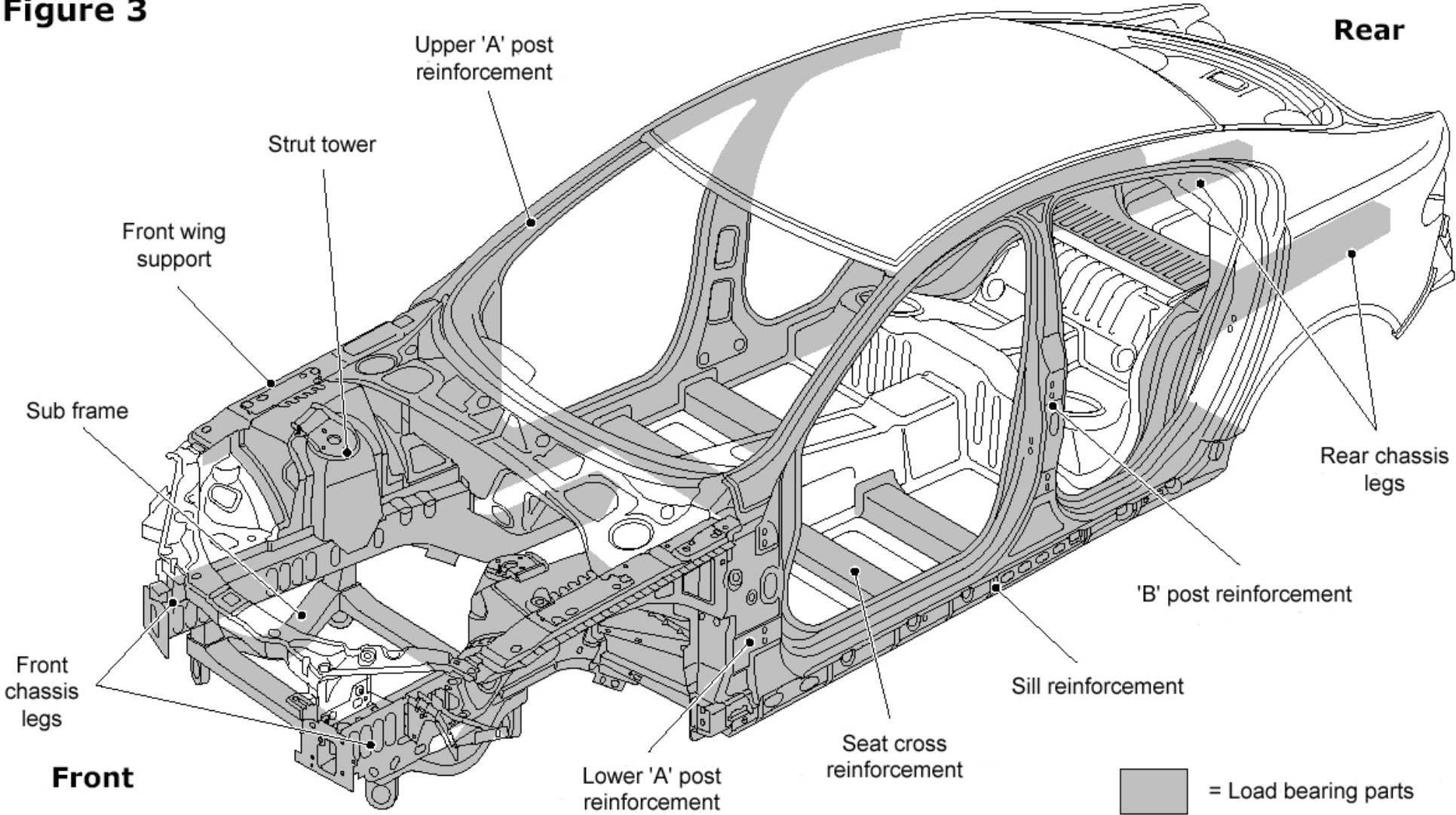

Appendix C – Structural Integrity and Corrosion

Figure 4

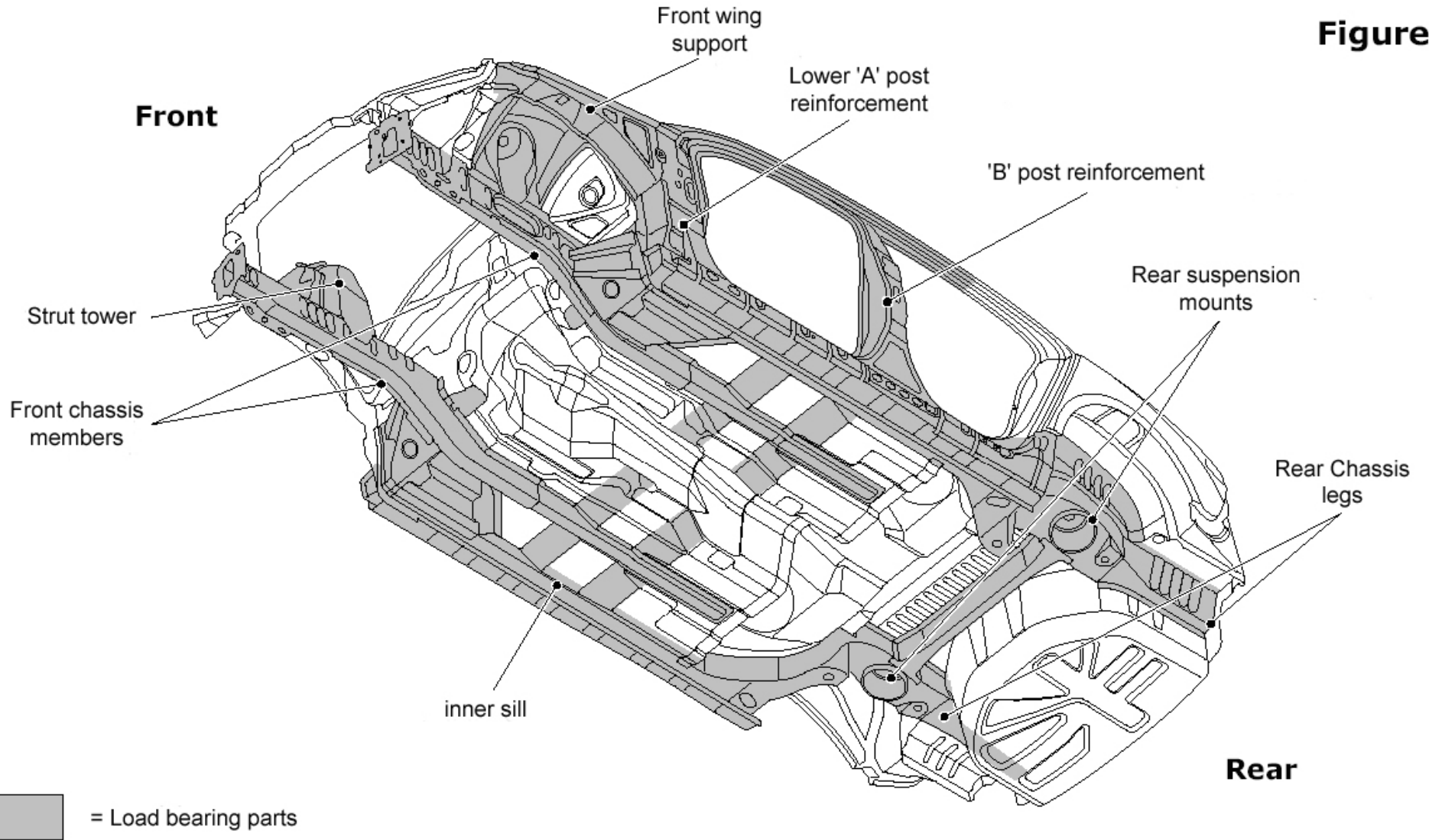

Appendix D – Tyre Size, Ply Rating and Load Index Tables

1. Load Index Tables

How to use these tables:

- Locate the line entry corresponding to the load index marked on the tyre sidewall.
- Read off the maximum axle load (kg) for these tyres in 'SINGLE' or 'TWIN' formation, as appropriate e.g. 121/120 = 2900 single, 5600 dual.
- If a tyre has only one load index marked, then that index refers to use in single formation. Such tyres can be used in dual formation by applying the following formula: **Max. load in dual formation = Max. load shown for single x 1.91.**

Load Index	Single Kg	Dual Kg
70	670	1340
71	690	1380
72	710	1420
73	730	1460
74	750	1500
75	774	1548
76	800	1600
77	824	1648
78	850	1700
79	874	1748
80	900	1800
81	924	1848
82	950	1900
83	974	1948
84	1000	2000
85	1030	2060
86	1060	2120
87	1090	2180
88	1120	2240
89	1160	2320
90	1200	2400
91	1230	2460
92	1260	2520
93	1300	2600
94	1340	2680
95	1380	2760
96	1420	2840
97	1460	2920
98	1500	3000
99	1550	3100
100	1600	3200
101	1650	3300
102	1700	3400
103	1750	3500
104	1800	3600
105	1850	3700
106	1900	3800
107	1950	3900
108	2000	4000
109	2060	4120

Load Index	Single Kg	Dual Kg
110	2120	4240
111	2180	4360
112	2240	4480
113	2300	4600
114	2360	4720
115	2430	4860
116	2500	5000
117	2570	5140
118	2640	5280
119	2720	5440
120	2800	5600
121	2900	5800
122	3000	6000
123	3100	6200
124	3200	6400
125	3300	6600
126	3400	6800
127	3500	7000
128	3600	7200
129	3700	7400
130	3800	7600
131	3900	7800
132	4000	8000
133	4120	8240
134	4240	8480
135	4360	8720
136	4480	8960
137	4600	9200
138	4720	9440
139	4860	9720
140	5000	10000
141	5150	10300
142	5300	10600
143	5450	10900
144	5600	11200
145	5800	11600
146	6000	12000
147	6150	12300
148	6300	12600
149	6500	13000



Load Index	Single Kg	Dual Kg
150	6700	13400
151	6900	13800
152	7100	14200
153	7300	14600
154	7500	15000
155	7750	15500
156	8000	16000
157	8250	16500
158	8500	17000
159	8750	17500
160	9000	18000
161	9250	18500
162	9500	19000
163	9750	19500
164	10000	20000
165	10300	20600
166	10600	21200
167	10900	21800
168	11200	22400
169	11600	23200
170	12000	24000
171	12300	24600
172	12600	25200
173	13000	26000
174	13400	26800
175	13800	27600
176	14200	28400
177	14600	29200
178	15000	30000
179	15500	31000



Appendix D – Tyre Size, Ply Rating and Load Index Tables



2. Tyre size and ply rating tables

How to use these tables:



- Locate the line entry corresponding to the size and ply rating marked on the tyre sidewall.
- Read off the maximum axle load (kg) for these tyres in 'SINGLE' or 'TWIN' formation, as appropriate.
- These tables show the maximum axle load for tyres in single and dual (twin) formation. If a tyre has only one load index marked, then that index refers to use in single formation. Such tyres can be used in dual formation by applying the following formula: **Max. load in dual formation = Max. load shown for single x 1.91.**



Nominal Tyre Size	Ply Rating	Maximum Axle Load (Kg)	
		Single Tyres 	Twin Tyres 
145-13C	6	970	1840
145-13C	8	1120	2120
560-13C	6	1020	1940
590-13C	6	1070	2090
640-13C	6	1280	2240
640-13C	8	1430	2750
670-13C	6	1380	2650
670-13C	8	1580	3050
1050-13	12	4320	7880
1050-13	14	4830	8900
155-14C	6	1070	2040
165-14C	6	1300	2460
165-14C	8	1460	2760
175-14C	6	1430	2680
175-14C	8	1550	3000
185-14	RADIAL	1200	2300
185-14	REINFORCED RAD	1340	2560
185-14	4	1340	2560
185-14C	6	1550	2920
185-14C	8	1700	3200
195-14	RADIAL	1300	2490
195-14	REINFORCED RAD	1500	2870
195-14C	6	1700	3210
195-14C	8	1900	3600
205-14	RADIAL	1420	2720
205-14	REINFORCED RAD	1650	3160
205-14C	6	1850	3510
205-14C	8	2060	3900
215-14C	8	2240	4240



Nominal Tyre Size	Ply Rating	Maximum Axle Load (Kg)	
		Single Tyres 	Twin Tyres 
590-14C	6	1170	2240
600-14C	8	1260	2400
640-14C	6	1330	2550
650-14	4	970	1860
650-14C	6	1300	2460
650-14C	8	1500	2840
670-14C	6	1430	2750
670-14C	8	1680	3160
700-14	4	1070	2050
700-14C	6	1380	2650
750-14	4	1200	2300
750-14C	6	1530	2950
750-14C	8	1730	3360
11-15	6	2240	-
145-15C	8	1230	2320
185-15c	8	1750	3400
590-15C	6	1220	2340
640-15C	6	1380	2650
670-15C	6	1530	2900
670-15C	8	1780	3460
670-15	10	2000	3900
700-15C	6	1750	3400
700-15C	8	1940	3760
700-15	12	2440	4580
750-15C	6	1830	3560
750-15C	8	2060	3970
750-15	10	2340	4370
750-15	12	2750	5340
750-15	14	3150	6100
750-15	16	3660	6860

Nominal Tyre Size	Ply Rating	Maximum Axle Load (Kg)	
		Single Tyres 	Twin Tyres 
825-15	12	3050	5590
825-15	14	3360	6360
825-15	18	4680	8540
825-15	20	5000	9440
1000-15	12	3870	7120
1000-15	14	4320	8130
1000-15	16	5020	9580
1000-15	18	5400	10170
175-16C	6	1500	2840
175-16C	8	1650	3100
185-16C	8	1800	3400
195-16C	8	1950	3700
205-16C	6	1900	3610
205-16C	8	2120	4000
215-16C	6	2120	4000
215-16C	8	2300	4360
235-85-16	10	2760	5040
600-16	6	1380	2550
600-16	8	1530	2920
600-16	10	1830	3300
650-16	6	1530	2920
650-16	8	1830	3460
650-16	10	2040	3900
700-16	6	1730	3260
700-16	8	2040	3870
700-16	10	2340	4480
700-16	12	2650	5000

Appendix D – Tyre Size, Ply Rating and Load Index Tables

Nominal Tyre Size	Ply Rating	Maximum Axle Load (Kg)	
		Single Tyres	Twin Tyres
			
750-16	6	2040	3870
750-16	8	2240	4270
750-16	10	2500	4720
750-16	12	2900	5600
825-16	8	2650	4880
825-16	10	2850	5440
825-16	12	3300	6400
825-16	14	3600	6800
900-16	6	2360	4360
900-16	8	2720	5140
900-16	10	3050	5600
900-16	12	4070	7200
900-16	14	4320	7800
1050-16	12	4580	8130
1400-16	18	7880	-
1400-16	20	8390	-
1400-16	22	9150	-
9.50-16.5	6	2130	3750
825-17	10	3260	5850
825-17	12	3560	6200
825-17	14	3820	7200
8-17.5C	8	2300	4480
8-17.5	10	2570	5000
8.5-17.5	RADIAL	2900	5600
9.5-17.5	RADIAL	3400	6400
8-19.5	RADIAL	3100	6000
9-19.5	RADIAL	3800	7200
9.5-19.5	RADIAL	4240	7800
600-20	6	1430	2750
600-20	8	1630	3100
600-20	10	1830	3460
650-20	6	1830	3460
650-20	8	2240	4070
650-20	10	2440	4680
700-20	8	2240	4480
700-20	10	2650	4880
700-20	12	2850	5340

Nominal Tyre Size	Ply Rating	Maximum Axle Load (Kg)	
		Single Tyres	Twin Tyres
			
750-20	8	2850	5340
750-20	10	3260	6000
750-20	12	3600	7000
825-20	10	3560	6610
825-20	12	3820	7200
825-20	14	4120	7800
900-20	10	4070	7630
900-20	12	4580	8240
900-20	14	5000	9200
1000-20	12	4830	8640
1000-20	14	5340	9720
1000-20	16	6100	10900
10.5-20	6	2800	-
1100-20	12	5340	9660
1100-20	14	6100	10900
1100-20	16	6610	11600
1200-20	14	6100	10600
1200-20	16	6860	12000
1200-20	18	7630	13010
12.5-20	10	3700	-
1300-20	16	7800	-
1300-20	18	8900	-
1300-20	20	*9300	-
1400-20	18	9150	-
1400-20	20	*9510	-
1400-20	22	*10000	-
14.5-20	10	4000	-
1500-20	20	10600	-
1500-20	22	11600	-
1500-20	24	12600	-
1600-20	14	6100	-
1600-20	20	11400	-
1600-20	22	12500	-
1600-20	24	13600	-
13/80-20	18	7300	13000
14/80-20	18	8250	-

Nominal Tyre Size	Ply Rating	Maximum Axle Load (Kg)	
		Single Tyres	Twin Tyres
			
1100-22	12	5590	10170
1100-22	14	6100	10810
1100-22	16	6860	12000
9-22.5	10	3560	6610
9-22.5	12	3820	7200
9-22.5	14	4120	7800
10-22.5	10	4070	7630
10-22.5	12	4580	8240
10-22.5	14	5000	9200
11-22.5	12	4830	8640
11-22.5	14	5340	9720
11-22.5	16	6100	10900
13-22.5	18	7500	13000
10/70-22.5	14	5000	9200
11/70-22.5	12	5300	9720
11/70-22.5	14	5600	10300
11/70-22.5	16	6100	10900
12/70-22.5	16	6610	11600
13/70-22.5	18	7630	13010
275/70-22.5	RADIAL	5000	9200
275/70-22.5	16	6100	-
315/70-22.5	16	6610	11600
900-24	12	5090	9150
900-24	14	5340	10170
1000-24	14	6100	10500
1100-24	12	5850	10300
1100-24	14	6610	11200
1100-24	16	7120	12300
1200-24	14	6610	-
1200-24	16	7370	-
1200-24	18	8130	-
1200-24	20	9000	-
1400-24	18	10000	-
1400-24	22	11200	-
11-24.5	14	5830	10800

Note: Items marked ‘ * ’ are not suitable in UK over 9200Kg due to minimum tread width requirement of 300mm